

December

25 cents

Science and Invention

FORMERLY

**ELECTRICAL
EXPERIMENTER**

**WATER CURTAIN
PROTECTS FIREMEN**
See Page 850

Claudius R. Grover
Lock Box 35
St. Joseph, Minn.



VOL. VIII No. 8

SCIENCE AND INVENTION

DECEMBER, 1920

BE A CERTIFICATED ELECTRICIAN



I WILL TRAIN YOU AT HOME

A real position like this—for you

The country needs thousands of trained, **Certificated Electricians** to fill good positions—and at big pay! It's all a matter knowing how, and I will teach you by my up-to-date modern instruction. You can learn at home, without interfering with your regular work, by my highly successful method of **Home Instruction in Practical Electricity**. Prepare NOW, and be ready in a few months to earn your

\$65 to \$175 a Week

Send for This Book

My book, "HOW TO BECOME AN EXPERT ELECTRICIAN," has started thousands of young men on the way to splendid success. A new edition of this has just been printed. I want every young man interested in Electricity to have a copy, and will send you one **ABSOLUTELY FREE AND PREPAID**. Write me today.

How I Train My Students

As Chief Engineer of the Chicago Engineering Works I know exactly the kind of training a man needs to enable him to get and hold good positions, and to earn big pay. I have trained hundreds of men who are holding splendid electrical positions. Many are now successful **Electrical Contractors**.

I give each of my students personal attention and a complete and thorough training. I give him a **SPLENDID ELECTRICAL OUTFIT FREE**, and much of the training is done by actual work. When my students graduate and receive their Cer-

tificate they are ready for a real position. But **still more**, at any time you wish you can come to **our** splendidly equipped Electrical Shops for special training. No other school can give you this.

A Real Opportunity for You

Wishing is never going to make your dreams come true. You've got to **study—to learn**. A man is worth \$2 or \$3 a day from his neck down—and no more; but there is **no limit** to what he can be worth from his neck up.

A trained mind is what gets the big pay. It is this training that you need, and I can train you in a few months. Are you ambitious to make a real success—then send me the coupon—today.

Electrical Outfit—Free

To every student who answers this ad I am giving a Splendid Electrical Outfit of standard size, Electrical Tools, Instruments, Materials, etc., **absolutely free**. Furthermore, to every Electrical Student I give a truly **valuable** surprise that I cannot explain here.

Free Employment Service

I am continually receiving requests from employers to send them trained Electrical men. I assist my students to secure good positions. I keep in touch with them for years, helping and advising them in every possible way.

WRITE NOW—DON'T DELAY

Delay never got you anything. Action is what counts. Get started—and get started now. Write me, or send me the coupon, right NOW.

L. L. COOKE
Chief Engineer
Dept. 20Y

CHICAGO ENGINEERING WORKS
1918 Sunnyside Ave. CHICAGO

USE THIS "FREE OUTFIT" COUPON

Name

Address

City State

Chief Engineer
COOKE
Dept. 20Y
1918 Sunnyside
Ave., CHICAGO, ILL.

Six: Send at once—
fully prepaid and entirely
free—complete particulars of
your great offer for this month.

YOU CAN DO IT



An Amazingly Easy Way to Earn \$10,000 a Year

Let Me Show You How Free

TO the average man the \$10,000 a year job is only a dream. Yet today there are a surprising number of men earning five figure salaries who were merely dreaming of them a short while ago. The secret of their success should prove a startling revelation to every ambitious man who has ever aspired to get into the \$10,000 a year class.

There is nothing fundamentally "different" about the man whose salary runs into five figures. He is made of the same stuff as you and I. It is not necessary that he must enjoy the privilege of some influential connection or "pull." For example take J. P. Overstreet, of Dallas, Texas. A few short years ago he was a police officer earning less than \$1,000 a year. To-day his earnings are in excess of \$1,000 a month—more than \$12,000 a year. C. W. Campbell, Greensburg, Pa., was formerly a railroad employee on a small salary—last month his earnings were \$1,562.

Why Salesmen Earn Such Big Pay

Just stop a moment and think over the successful men of your acquaintance. How many of them are connected with some form of selling? If you will study any business organization you will see that the big jobs go to the men who sell, for upon their efforts depend the profits a company makes. Without trained men to place a product on the market, the finest goods are worth no more than so much clay. Salesmen are the very nerve centers of a business. Is it any wonder that they earn big pay?

The man who starts working as a bookkeeper or clerk for \$25.00 a week, never increases his value to the firm. Any advance in pay is merely a reward for length of service. At the end of ten years he is no more essential to the life of the organization than he was at the end of ten weeks. He is only a necessary liability—drawing his pay because somebody must be found to work at the unimportant, routine jobs. Once established in the rut, he becomes a cog in the machine—when he is worn out, he can be easily and cheaply replaced.

Why Don't You Get Into the Selling Field?

Mr. Overstreet, Mr. Campbell and the others whose letters you see on this page are all successful salesmen. They realized their ambitions by landing \$10,000 jobs in an amazingly simple way, with the help and guidance of the National Salesmen's Training Association. Sometime—somewhere back in the past, each one of them read of this remarkable course of Salesmanship training and Employment Service just as you are reading of it to-day. Each one of them was dissatisfied with his earning capacity—as perhaps you are—and each one cast his lot with the N. S. T. A. To-day they are important factors in the business world—enjoying all the comforts and luxuries money can buy. And yet they are not exceptions, for there are thousands of N. S. T. A. trained salesmen who are making big money, as we will be only too glad to show you if you will mail the coupon.

We Train You and Help You Land a Job

The National Salesmen's Training Association is an organization of top-notch salesmen and sales managers formed for the express purpose of training men in the science of successful selling. You do not need to know the first thing about selling—for the N. S. T. A. trains you from the ground up—gives you a complete insight into selling methods—in your spare time without making it necessary

Read These Amazing Stories of Quick Success

Earned \$524 in Two Weeks

I have never earned more than \$60 a month. Last week I cleared \$306 and this week \$218. You have done wonders for me.—Geo. W. Kearns, 107 W. Park Place, Oklahoma City, Okla.

I Now Earn as High as \$100 a Day

I took your course two years ago. Was earning \$16 a week clerking. Am now selling many of the largest firms in the U. S. I have earned more than \$100 in a day. You secured me my position. Our Sales Manager is a graduate of yours.—J. L. DeBonis, 1628 S. Crawford Ave., Chicago, Ill.

Earns \$1,562 in Thirty Days

My earnings for the past thirty days are \$1,562, and I won Second Prize in March although I only worked two weeks during that month.—C. W. Campbell, Greensburg, Pa.

Earned \$1,800 in Six Weeks

As soon as I received a letter from you and your literature, I knew that I was on the right track and very soon after I applied for a position as a Salesman to one of the firms whom you informed me were in need of a Salesman and to whom you had recommended me. As soon as they received my application, which was by mail, they wired me to come for an appointment which I did, with the result being that I sold my services to them in about thirty minutes, took a territory in Illinois and Wisconsin and made a success of it from the very first week.

From that time on I have been what might be termed as a "high pressure" Salesman, selling lines where nine out of ten Order Takers would fail. I have sold goods in a highly successful manner in nine or ten States, both North and South. My earnings for March were over \$1,000 and over \$1,800 for the last six weeks, while last week my earnings were \$356.00. I travel eleven months out of the year, working five days each week.

The N. S. T. A. dug me out of a rut where I was earning less than \$1,000 a year and showed me how to make a success.—J. P. Overstreet, Dallas, Texas.

to give up your present position until you are ready to begin actual selling.

In addition to this remarkably efficient course of training, the N. S. T. A. maintains a Free Employment Service to help its Members to jobs in the lines for which they are best suited. This in itself is of incalculable value for it allows the prospective salesman to make a complete survey of the selling field and to select the work which most appeals to him.

Salesmen Are Needed—Now!

Get out of that rut! Work for yourself! Salesmanship is the biggest paid of all professions. Just because you have never sold anything is no sign that you can't. We have made Star Salesmen of men from all walks of life, with no previous selling experience. These men have jumped from small pay jobs to big selling positions and handsome incomes. The same training on which they founded their success is open to you. You can follow in their footsteps. Why don't you get in a class with men who make real money? Never before have the opportunities been greater. At least you cannot afford not to investigate the great field of Selling and see what it offers you. It will only cost you a 2 cent stamp and the facts and proof you will receive will surprise you.

Free Book on Salesmanship

Just mail the coupon or write for our free illustrated Book, "A Knight of the Grip," which we will be glad to send without any obligation on your part. Let us prove to you that regardless of what you are doing now, you can quickly become a Star Salesman. Let us show you how you too can step into the ranks of these big money makers of business. See how easily you can learn this fascinating, big pay profession at home in your spare time. Learn what we have done for others and what we stand ready to do for you. Don't put it off until to-morrow—write us to-day. Every hour lost keeps you that much farther from success. Mail the coupon at once.

National Salesmen's Training Association
Dept. 42-W, Chicago, Ill., U. S. A.

National Salesmen's Training Association
Dep. 42-W, Chicago, Ill., U. S. A.

Please send me, without any obligation on my part your free Book, "A Knight of the Grip," and full information about the N. S. T. A. system of Salesmanship training and Employment Service. Also a list showing lines of business with openings for salesmen.

Name.....

Street.....

City..... S. I. 12-20

Vol. VIII
Whole No. 92

Science and Invention

FORMERLY
ELECTRICAL EXPERIMENTER
233 FULTON STREET-NEW YORK

December, 1920
No. 8.

Published by Experimenter Publishing Company, Inc. (H. Gernsback, Pres.; S. Gernsback, Treas.; R. W. DeMott, Sec'y), 233 and 236 Fulton Street, New York

Ice Boiling-Hot

DID you ever hear of five different kinds of ice? Perhaps not. The only kind of ice that you have ever seen or heard of before is the good old-fashioned, common, ordinary ice. But of late, many new things are happening in the world of science and the discovery of the existence of five different kinds of ice is one of them.

In his recent researches, Professor P. W. Bridgman, of the Carnegie Institute at Washington, has made some very remarkable discoveries due entirely to extraordinary high pressures. He investigated a great many substances which he subjected to tremendous pressures and under such conditions a number of surprising things happen. Take, for instance, water. If we subject it to a pressure of about 300,000 pounds to the square inch, water first becomes solid, turning into ice, *altho it is nearly boiling hot!*

At ordinary atmospheric pressures water turns to ice at about 32° Fahrenheit. But as we compress it to very high figures, we find that water is indeed a highly compressible substance—a thing that was not known before. Thus Dr. Bridgman has *compressed water to 80 per cent. of its volume!* During such compression the water turns to ice at all sorts of temperatures, and the four new and different kinds of ice that were discovered are all considerably denser than water. In other words, such a cake of ice *would sink in water*, instead of floating as ordinary ice does.

Water, however, is only one of the substances that behaves strangely under high pressures. Take phosphorus, for example. Ordinarily this substance is known in two forms, namely, the ordinary yellow or white phosphorus and the red, allotropic variety, both, however, having practically the same general physical characteristics. White phosphorus is highly oxidizable and cannot be left in the open air without danger of ignition. It is a non-conductor of electricity and as soft as wax. If, however,

we subject this phosphorus to the enormous pressure of some 175,000 pounds per square inch we obtain an entirely new substance which is neither the usual nor the allotropic red phosphorus, but something entirely different. We obtain *black phosphorus* which is very hard and which only oxidizes at a very slow rate. It is also 15 per cent. denser than the white variety. It can be handled with the fingers with impunity and *the material is a good conductor of electricity.*

Dr. Bridgman found that at high pressures, paraffin became more rigid than soft steel; soft rubber became as brittle as glass. Another noteworthy feature was discovered in the course of these experiments and that is that nearly all metals such as metallic wires subjected to tremendous pressures become slightly more conductive to the electrical current.

There is no doubt that thru these researches we will learn much about the nature of the atom as well as about the electron if we subject materials to still higher pressures. This field is practically virgin and we may say that only the surface has been scratched so far. What will happen, for instance, if many of our well-known substances are subjected to pressures of say two or three million pounds per inch, or higher, is difficult to conceive today. Of course today we have no control of such pressures because there exist no materials sufficiently hard to resist such titanic compression. But science will surely find a way to obtain some alloys unknown today that will lend themselves to such pressures. It is even thought possible in some quarters that in high pressures we have the key to our alchemist's dreams of changing one metal into another, from base to precious, or vice versa. Although this may sound extreme and while the theory is not given credence by most scientists, still the example of phosphorus is pointed out as to what may happen, given sufficiently high pressures.

H. GERNSBACK.

CONTENTS FOR DECEMBER, 1920

WATER CURTAIN PROTECTS FIREMEN.....Front Cover	
From a Painting by Howard V. Brown	
FLOATING SUNKEN SHIPS.....	839
EINSTEIN AND THE FOURTH DIMENSION.....	840
By H. Gernsback, Member of the American Physical Society	
SCIENCE IN PICTURES.....	842
SCIENTIFIC CHRISTMAS TOYS.....	844
A PROPHET OF SCIENCE.....By John De Quer	845
LIFE OR DEATH.....By Charles S. Wolfe	847
VON GUERICKE—THE WIZARD OF ATMOSPHERIC PRESSURE.....	848
By Prof. T. O'Connor Sloane, Ph.D., LL.D.	
WATER CURTAIN PROTECTS FIREMEN.....	850
THE LIGHT RAY PHONOGRAPH.....By Eric A. Dime	851
WHAT ARE DREAMS?.....By William M. Butterfield	852
LAMP FACTS FOR THE HOUSEHOLDER.....	853
THE SUBMACHINE GUN.....	854
MOVIE MODELS SHOW HOW MACHINES WORK...By Esther Lindner	859
POPULAR ASTRONOMY—HAS THE EARTH'S ROTATIONAL PERIOD CHANGED?.....	860
By Isabel M. Lewis, M.A., of the U. S. Naval Observatory	
MOTOR HINTS PRIZE CONTEST.....	863
HEAT FOR THE HOUSEHOLD.....By H. Winfield Secor	864
"LANDING LAKES" FOR AIRCRAFT.....	866
By R. T. Carabin, Ex-Lieut. A. E. F.	
THE BRITISH MYSTERY TOWERS.....	867
DIVING BELL RECLAIMS DIAMONDS.....	868
THE AMATEUR MAGICIAN.....By Joseph H. Kraus	870
PRACTICAL CHEMICAL EXPERIMENTS—SOME METALS AND THEIR PROPERTIES.....	871
By Prof. Floyd L. Darrow	
XMAS ELECTRIC AMUSEMENTS.....	872
FASCINATING CHEMICAL EXPERIMENTS.....	879
By O. Ivan Lee, B.Sc.	
TRANSMITTING PHOTOGRAPHS BY RADIO.....	883
By Pierre H. Boucheron	
WHAT TO INVENT.....By Jay C. Hobson	885

SCIENCE AND INVENTION is published on the 15th of each month at 233 Fulton Street, New York. There are 12 numbers per year. Subscription price is \$3.00 a year in U. S. and possessions. Canada and foreign countries, \$3.50 a year. U. S. coin as well as U. S. stamps accepted (no foreign coin or stamps). Single copies, 25 cents each. A sample copy will be sent gratis on request. Checks and money orders should be drawn to order of EXPERIMENTER PUBLISHING CO., Inc. If you change your address notify us promptly, in order that copies are not mis-carried or lost. All communications and contributions to this journal should be addressed to: Editor, SCIENCE AND INVENTION, 233 Fulton Street, New York. Un-accepted contributions cannot be returned unless full postage has been included. ALL accepted contributions are paid for on publication. A special

rate is paid for novel experiments; good photographs accompanying them are highly desirable.

SCIENCE AND INVENTION. Monthly. Entered as second-class matter at the New York Post Office under Act of Congress of March 3, 1879. Title registered at the Patent Office. Copyright, 1920, by E. P. Co., Inc., New York. The Contents of this magazine are copyrighted and must not be reproduced without giving full credit to the publication.

SCIENCE AND INVENTION is for sale at all newsstands in the United States and Canada; also at Brentano's, 37 Avenue de l'Opera, Paris. Sole British Agents—Geoffrey Parker & Gregg, 62 and 8A The Mall, Ealing, London. Member of the Audit Bureau of Circulation.

SOME men seem to attract success, power, wealth, health and attainment with very little conscious effort, others conquer with great difficulty, still others fail altogether to realize their ambitions, desires and ideals.

Why is this so?

The Master Key will tell you why! It will tell you that these things are controlled by Natural Laws, precisely the same as the falling of an apple.

The Master Key is a key with which many are converting loss into gain, fear into courage, despair into joy, hope into fruition. No one will emerge from its magic pages but with a firmer grasp of the future, a surer understanding of what he can do

This may seem too good to be true, but remember that within a few years, by the touch of a button or the turn of a lever, science has placed almost infinite resources at the disposal of man. Is it not possible that there are other laws containing still greater possibilities?

An understanding of this law will enable you to control every other power which exists. It is without doubt the greatest discovery of the Twentieth Century. In it may be found the remedy for every ill, the solution to every difficulty, the gratification of every desire; in fact, it would appear to be the Creator's magnificent provision for human emancipation.

Conclusive evidence as to the truth of these statements will be sent to any address, without cost or obligation of any kind.

Charles F. Haanel, 203 Howard Bldg., St. Louis, Mo.

\$100,000 Worth of Health and Beauty—FOR YOU!

Try This Wonderful New Way 10 Days Free

Your energy depends on your health. Your success depends on your energy. You cannot get far if you are handicapped by poor health or just "average" health. You must possess SUPER-health, and SUPER-energy in order to rise above the crowd. If you are troubled with aches and pains, if you are rheumatic, if you suffer from colds, asthma, constipation, insomnia, nervousness, neuralgia, lumbago, indigestion—you cannot possibly do your best work. And if your skin is pimply, blotched, roughened,—if your complexion hurts you instead of helping you, then you lose much of the force of your personality. You can have REAL health and REAL energy, with every nerve and atom atingle with life and eagerness—you can have REAL beauty—all through wonderful Violet Rays, the most healing and curative form of electricity yet discovered. This VIOLET RAY kind of health and beauty may be worth \$100,000 or more to you, for it means that you are attractive, energetic, buoyant, sparkling with "pep" and personality every day.

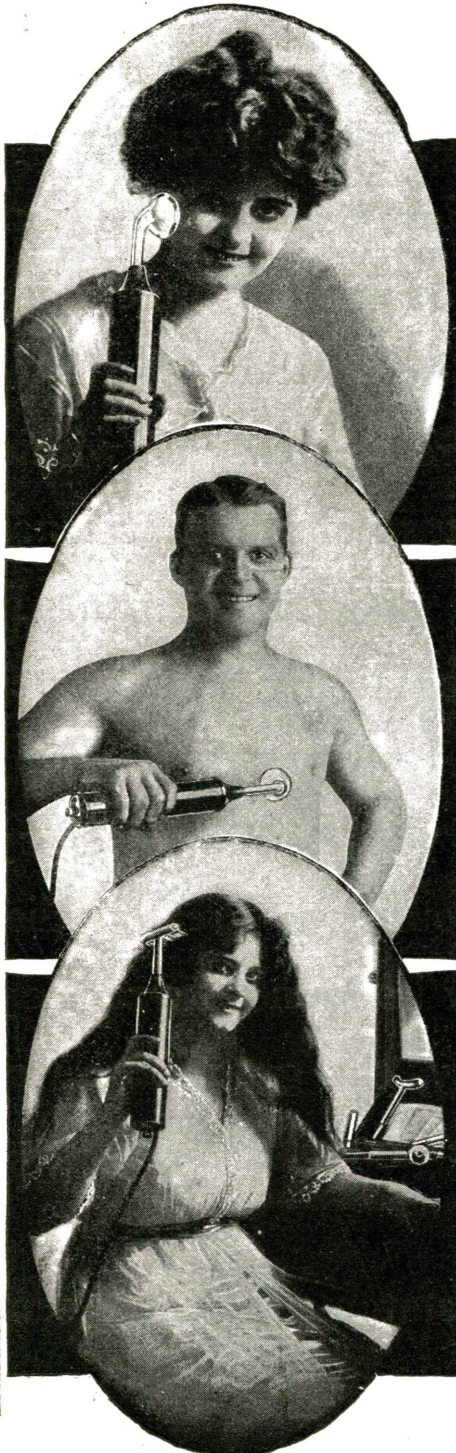

VIOLET RAYS

Think of scores of volts of electricity going completely through your entire system, yet with no trace of shock or pain. Think of the helpful, healing force of this mysterious power massaging every cell in your body, strengthening you, reviving you, giving you double or treble your present energy and vitality, yet with no trace of pounding or vibration. That is what you get with Violet Rays. Nikola Tesla's great discovery. Now used by thousands of physicians, chiropractors, osteopaths, drugless healers, hospitals, sanitariums. Used by the greatest beauty specialists in the country, and now YOU can have Violet Ray treatments in your own home, for here at last is a portable Violet Ray machine with which you can treat yourself in your own home at less than one cent per treatment. Attach to any electric light socket or use Battery Outfit Complete if you have no electric light. Carry it anywhere.

Nothing Like It

The Vi-Rex is not a vibrator. It does not contract the muscles or shock the nerves. Its magic rays pass through every cell and tissue, creating "cellular massage"—the most beneficial electrical treatment known. It leaves no soreness after use, only a delightful sensation of agreeable relief.

Violet Rays penetrate glass, yet are harmless even to infants. No shock. No vibrations. Better than gallons of drugs and liniments. Better than tons of cosmetics. Soothing or stimulating, as desired. There is nothing else that even remotely resembles Violet Ray treatments.

10 Days' Trial

Take twenty Violet Ray treatments in your own home. These treatments would cost you \$50 to \$100 at your physician's or beauty specialist's. Now, through our special, liberal offer, you can try Violet Ray treatments without risking a penny. Use this wonderful machine for ten days. If you do not find quick relief, if you do not feel better, sleep better, eat better, look better, send it back and you will not be out one penny. Prove to yourself that Violet Rays bring you the magic of electricity in its most wonderful curative form.

New Book Free

We want you to know in detail about Violet Rays. We want you to see for yourself how it has helped thousands of others. We want you to learn what physicians, sanitariums and beauty specialists think of this wonderful new Violet Ray machine. Learn how you can have superb

Violet-Ray Treatments Given in the Home

The Violet-Ray is the greatest force for health and beauty which science has ever produced. A comparatively recent discovery, it has already won universal indorsement in the medical profession.

At last it brings within everyone's reach the health-giving qualities of electricity. It brings them in a form that is safe, pleasant and beneficial to the highest degree.

The Violet-Rays are produced by a new instrument and applied by means of glass attachments or electrodes. The electrical discharge may appear to the eye to be a single spark, but in reality is made up of a number of successive sparks following each other with such great rapidity that they change directions millions of times per second, a speed that the eye cannot note, nor the senses feel. For this reason the current produced by the Violet-Ray is sometimes called a "High Frequency Current."

The Violet-Ray has a pleasant, stimulating effect wherever applied and brings the blood tingling to the surface, electrifying the tissues with life.

By holding any attachment in the hand a refreshing sense of warmth and exhilaration is produced, which causes restful relaxation. This sedative effect is most useful where the nutrition of the body needs to be improved, the nervous system reinvigorated and aids all the functions of the body in performing their duties.

Speaking of this machine, which is manufactured by the Vi-Rex Electric Company, Chicago, a prominent medical man said: "With continued use of the Vi-Rex, the ruddy glow of health returns to the pallid cheeks, you feel the joy of perfect blood circulation, you realize what it means to have every nerve, every organ in the body working in perfect harmony. Its exhilarating and permanent stimulation is powerful enough to reach and benefit every part of the body, yet it is so soothing, so absolutely delightful, that a single treatment will convince you of its wonderful merits."

health and radiant beauty. See for yourself the superior points of quality of this instrument. All this you will find in our great 52 page health and beauty book which will be sent you free. Simply mail the coupon or write a postal or letter. Do this now, before our special free trial offer is withdrawn.

VI-REX ELECTRIC CO.

DEPT. 412,
326 West Madison Street, Chicago, Ill.

VI-REX ELECTRIC CO.
Dept. 412 326 West Madison Street, Chicago, Ill.

Please send me, without any cost or obligation, your free book describing your Violet Ray Machine, and details of your free trial offer.

Name

Address

City..... State.....

What Would You Say?

If you knew you deserved a raise in salary and wanted to be sure of getting it?



If you were suddenly called on to address a large gathering?

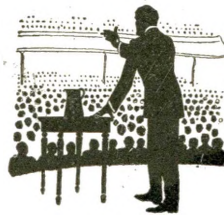

If you had to smooth over a particularly embarrassing situation?



If you wanted to "put over" a big idea and circumstances were against you?



If you had to pacify an irate customer or else lose his business?

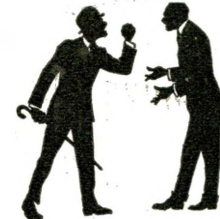

If you wanted to land a certain job and were faced with keen competition?



JUST suppose you were confronted with any one of the above situations.

Suppose, for instance, that you wanted a raise in salary—that you knew you were worth it—that you simply had to have it.

Now be honest with yourself—would you know how to ask for it in such a way that you could be *sure* of getting it? Could you go up to your boss and present the facts of your case so as to leave absolutely no room for any possible objections?

Or suppose you had a chance to get the job that you had been waiting for all your life—and you found that dozens of others with just as good qualifications as you possessed—were after the job too.

Could you convince your prospective employer that you were *the* man for the job? Could you, just by talking to him, make him feel just as anxious to get you as you were to get the job?

The Secret

You could, and easily, if you knew the *one big secret of persuasion!*

Let me tell you something. In December, 1918, a young man named James Baker was discharged from the army. He was homeless, and was practically penniless. But he had a big idea. And he was determined to put this idea over.

For three months he tried to get someone to capitalize his enterprise, but his efforts were in vain. Even the fact that consented to give him a hearing scoffed at his idea, and advised him to abandon it.

Then, almost overnight, he learned this wonderful secret of persuasion.

Three days later he succeeded in getting just twice the amount of capital he originally set out for, and shortly afterward his product appeared on the market. In the past 10 months Baker has made over \$75,000.

Another case, just as interesting, is that of James C. Bently.

For seven years Bently had been a salesman for a large New England manufacturing concern. He had never met with more than indifferent success. He was just a plain, ordinary salesman—an "order taker" if you will.

Then, suddenly, his sales picked up. In

one month he had doubled his former monthly sales record. In three months he had sold more than he sold all the previous year. A short while later he was promoted to Sales Manager.

Then he took on several new salesmen and under his direction new territory was developed. Sales increased by leaps and bounds. Last year a big addition was built to the factory to handle the increased business. Today Bently is vice-president of this concern and is earning over \$18,000 a year. And all his success he owes to the *one big secret of persuasion.*

Some may say that these are only two isolated cases of what the power of persuasion has done. But are they? Not at all. I could relate scores of cases where the results have been just as remarkable.

Pet Idea "Goes Over"

For instance, there is the case of Arthur H. K. Richardson, who, until he was 48, was an actual failure. He owned a "one-horse" corner grocery store in a little town in Michigan. For ten years he had been trying to put through a "pet idea" of his, but everyone laughed at him. Then he put this wonderful secret to work for him. Today Richardson is a chief stockholder in a *chain store corporation* and has a net income of over \$60,000 a year!

What is this wonderful secret? It is simply this—swinging people around to your point of view, making them to think as you think, and then getting them to do just what you want them to do.

And this secret—the secret that has brought thousands of people more wealth and happiness than they had ever hoped for—is now yours. You can easily learn it, for it is now revealed in full in Dr. Frederick Houk Law's wonderfully simple seven-lesson course, "Mastery of Speech."

This remarkable course gives you the secret of talking convincingly. It shows you how to make what you say have the effect you want it to, whether you are talking to sell, to convince or to entertain. It will help you, as it has helped thousands of others, to overcome timidity. It will give you what nine out of ten men lack—confidence.

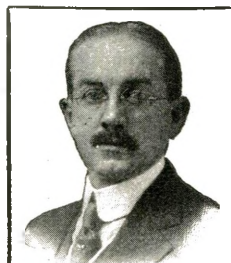

FREDERICK HOUK LAW

As educator, lecturer, executive, traveler and author few men are so well equipped by experience and training as Dr. Law to teach the art of effective speaking. His "Mastery of Speech" is the fruit of 20 years' active lecturing and instruction in Eastern schools and colleges preceded by an education at Oxford Academy, Amherst College, Columbia University, the Teachers College, Brown University, and New York University. He holds the degree of A.B., A.M., and Ph.D.

It shows you the art of brevity, the value of silence, how to use humor with telling effect, how to make and how to satisfy complaints. It tells you how to make oral reports to your superiors, how to ask the bank for a loan, and how to ask for an extension on your note. In a word, it gives you the secret of saying the right thing at the right time, no matter what the situation may be.

Results in One Evening

One of the remarkable things about this wonderful course is that it requires practically no study and very little time.

Anyone can grasp the principles in an evening. You will be amazed at the sudden improvement in your speech. Hundreds of letters from people in all walks of life prove that this secret brings almost immediate results.

So confident am I that you can, in one hour, learn this secret of persuasion, and that you can apply the principles of effective speech under all conditions, that I am willing to send you Dr. Law's course on free examination.

Send No Money

Don't send a penny. Merely mail the coupon or write a letter and the complete course will be sent you, all charges prepaid, at once. If you are not entirely satisfied, send it back any time within five days after you receive it and you will owe nothing.

On the other hand, if you are as pleased as are the thousands of other men and women who have used this course, send only \$5 in full payment. You take no risk and you have everything to gain, so mail the coupon at once before this remarkable offer is withdrawn.

Independent Corporation
Dept. L-11012 319 Sixth Avenue, New York
FREE EXAMINATION COUPON

Independent Corporation
Dept. L-11012 319 Sixth Avenue, New York

You may send me the Course or Courses checked below. Within five days after receipt I will either re-mail the Course (or Courses) or send you \$5.00 for each in full payment, except as noted.

- Mastery of Speech (\$5) Super-Salesmanship (\$5)
By Frederick Houk Law By Arthur Newcomb
- Roth Memory Course (\$5) Practical Course in Personal Efficiency (\$5)
By David M. Roth By Edward Earle Purinton
- How to Read Character at Sight (\$5) Money-Making Account System (\$3.50)
By Dr. K. M. H. Blackford By Wesley W. Ferrin
- Drawing, Art and Cartooning Course (\$5) Paragon Shorthand (\$5)
By Charles Lederer By Alexander Lichtenag

Name

Address

.....Elec. Exp. 12-20

NEW AND POPULAR BOOKS

The How and Why of Radio Apparatus By H. W. SECOR, E. E.

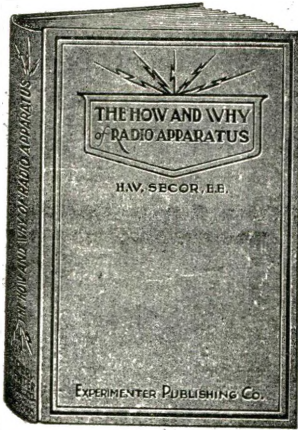

This newest book on radio matters fulfills a distinct gap in wireless literature in that, while the treatment is made as understandable and as free from mathematics as possible, it at the same time incorporates a wealth of technique and instruction for the Radio Amateur—the Radio Operator—the Installation and Designing Expert—as well as teachers and students of the subject in general.

A glance at the following list of chapters gives but a very scant idea of the extensive and useful radio knowledge provided in its text:

The Induction Coil; The Alternating Current Transformer; Radio Transmitting Condensers; The Spark-Gaps; Radio Transmitting Inductances; Radio Receiving Tuners; Radio Receiving Condensers; Detectors; Telephone Receivers; Radio Amplifiers; Construction of a Direct Reading Wavemeter and Decrementer; Antenna Construction; The Calculation and Measurement of

Inductances; Appendix containing very useful tables, covering all subjects treated in this very unusual book.
Cloth bound in Vellum de Luxe. Gold stamped and hand sewed; has 160 pages. Sizes of book 6 x 9 inches.

The How and Why of Radio Apparatus. Postpaid..... **\$1.75**

A Thousand and One Formulas By S. GERNSBACK

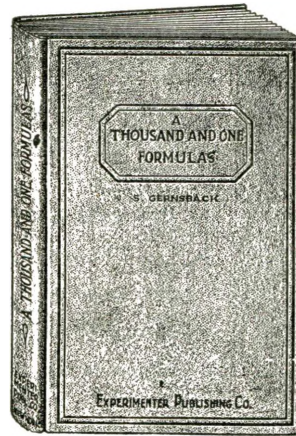

A Laboratory Hand Book for the Experimenter and for Everybody who wants to "do things."

A Book, brimful with very important and priceless information, collected and selected for years.

The recipes and formulas are classified in such a manner as to be available at once, without long research.

Here are some of the chapter headings:

Cements and Glues; Compositions of All Kinds; Glass and Glassworking; Inks; Leather Polishes; Metalcraft; Perfumery; Soaps and Extracts; Photography; Blue Print and other Paper; Plating; Pyrotechny; Polishes and Stains; Varnishes and Paints; Various Cleaning Formulas; Woodcraft; Chemical Laboratory Hints and Experiments; Mechanical Laboratory Hints and Experiments; Electrical Laboratory Hints and Experiments.

Besides there are a score of tables and hundreds of Illustrations and Diagrams. Book is cloth bound in Vellum de Luxe. Gold stamped and hand sewed. It contains 160 pages. The paper has been especially selected to stand rough handling in laboratories. Size 6 x 9 inches.

A Thousand and One Formulas, as described. Postpaid..... **\$1.75**

Design and Construction of Audion Amplifying Transformers

Radio and Audio Frequency Type

This latest and important book by Mr. Edward T. Jones, late Associate Editor of *Radio News*, will be of great interest to all radio amateurs throughout the land. The transformers shown in these books have never been described in print before, and have usually been considered a manufacturer's secret. Anyone who has several vacuum tubes cannot afford to do without this book because it will enable him to build the necessary amplifying transformers very readily. The designs are very simple and rugged, and anybody can make them without trouble.

The book is printed on good paper and has an attractive cover in two colors. Paper bound. Size 5 in. x 7 in. Contains many illustrations, diagrams and working data necessary to build the transformers.
Price, Postpaid 25c

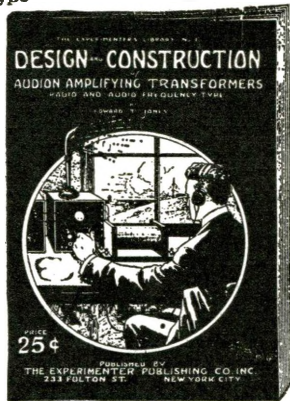

Wireless Course in 20 Lessons

By S. Gernsback, A. Les-carboursa and H. W. Secor, E. E.

A course that tells you everything you want to know about "Wireless," starting off in lesson No. 1 by explaining the Principles of Electricity. By simple, easy stages, this wonderful Course takes you into "Wireless" by the use of such simple language so skillfully used that of necessity you must understand every word. There is a whole lesson devoted to the Theory and Mathematics of this epoch-marking subject. The last lesson is devoted to a history of Wireless.

More than 50,000 of this course sold

Eighth Edition
Size of book is 7 x 10 1/4 in., 160 pages, 350 illustrations, 90 tables.

Flexible cloth cover, per copy.....75c
Stiff cloth cover, per copy..... **\$1.25** Postpaid

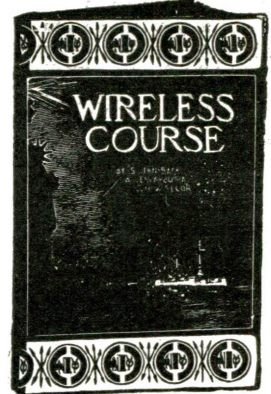

Experimental Electricity Course in 20 Lessons

By S. Gernsback and H. W. Secor, E. E.

A Course on the theory and practice of Electricity for Experimenters. One of the most complete and comprehensive treatises of this special subject ever published. Written by the same authors as the famous "Wireless Course."

Every phase of experimental electricity is treated comprehensively in plain English. New experiments are described and explained and nearly every application of Electricity in modern life is given in simple language.

Size of book is 6 x 9 in., 128 pages and more than 400 illustrations.

Flexible cloth cover, per copy.....75c

Stiff cloth cover, per copy..... **\$1.25**
Postpaid

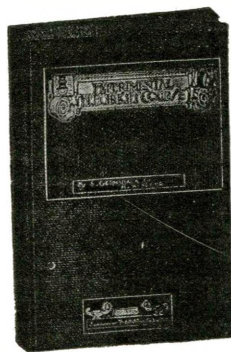

Two Remarkable Books

Book No. 1—How to make Wireless Sending Apparatus. .35c Postpaid.

Book No. 1 contains 100 pages, size 7 x 5 in., and 88 illustrations.

Book No. 2 contains 100 pages, size 7 x 5 in., and 90 illustrations.

Written and published entirely for the wireless enthusiast who wants to make his own radio apparatus. Only strictly modern instruments are described and the illustrations and descriptions are so clear and simple that no trouble will be experienced in making the instruments.



Book No. 2—How to make Wireless Receiving Apparatus. .35c Postpaid.



THE EXPERIMENTER PUBLISHING CO.

Book Dept. 236 Fulton Street

NEW YORK

These Books Are For Sale Also At the Following Dealers

Amer. Technical App. Co.
235 Fulton St., N. Y. C.
Baker Taylor Co.
354 Fourth Ave., N. Y. C.
E. P. Noll Co., 21 N. 7th, Phila., Pa.

Benwood Co., Inc.
3424 Olive St., St. Louis, Mo.
Continental Radio Supply Corp.
6 Warren St., N. Y. C.

F. S. Katzenback
35 E. State St., Trenton, N. J.
McDevitt & Wilson
30 Church St., N. Y. C.
Geo. Parezo & Co., Washington, D. C.

R. H. Macy Co.
New York City
Manhattan Elec. Supply
17 Park Place, N. Y. C.
Southern Elec. Co., San Diego, Calif.

John Wanamaker
New York, N. Y.
Marconi Wireless Tel. Co.
Montreal, Canada

Learn Electricity

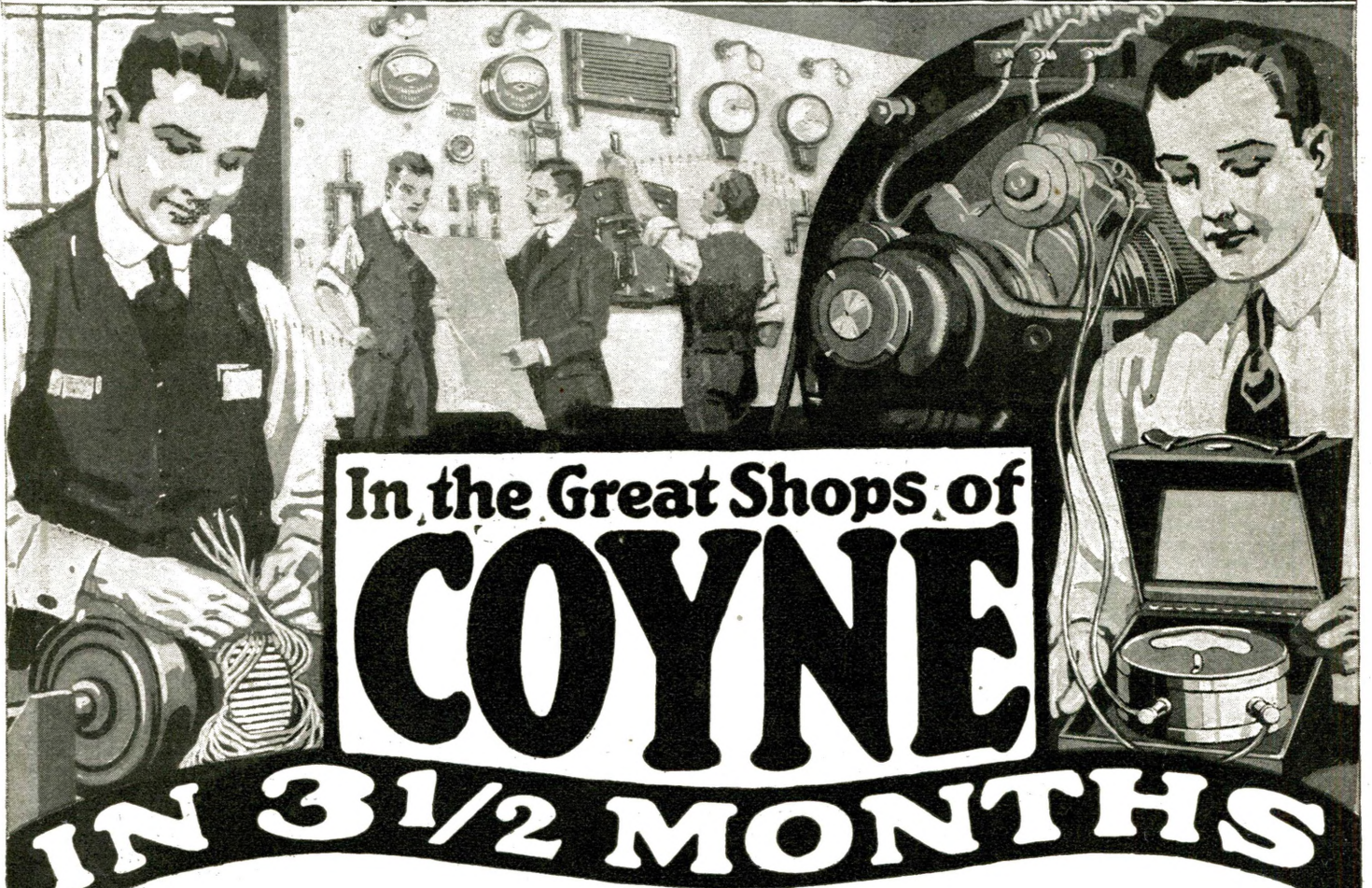

In the Great Shops of
COYNE

IN 3 1/2 MONTHS

Thousands of Electrical experts are needed to help rebuild the world. Come to Chicago to the great shops of Coyne and let us train you quickly by our sure, practical way, backed by twenty-one years of success. Thousands of our graduates have become experts in less than four months. *You* can do the same. *Now* is your big opportunity. Come—no previous education necessary.

Earn \$150 to \$500 a Month

in the Electrical business. Come here where you will be trained in these great \$100,000 shops. Experts show you everything and you learn right on the actual apparatus. You work on everything from the simple bell to the mighty motors, generators, electric locomotives, dynamos, switchboards, power plants, everything to make you a master electrician. We have thousands of successful graduates. Just as soon as you have finished we assist you to a good position.

Electro Automotive Course FREE

Every student enrolling in our electrical course at this time is given our big new electro automotive course free. This course includes complete training on the electrical systems of auto trucks, tractors and aeroplanes. Here we have automobile chassis, motors on the block, practically every lighting, starting and ignition system from the Ford to the Packard. Every type of magneto. Storage battery department, etc. Write us at once for particulars, as this offer cannot last long.

Earn While You Learn

If you haven't enough money now don't wait to save it. Our employment man places students in spare time jobs to earn their living expenses, or if they must earn all expenses he places them where they work half the time (generally right at electrical work) and go to school the other half. In this way they learn and at the same time earn and gain splendid experience.

BENNETT W. COOKE, President

COYNE TRADE AND ENGINEERING SCHOOLS

Dept. 2-Y 39-51 E. Illinois Street, Chicago, Ill.

Make Expenses in Chicago

Our employment and welfare department has assisted hundreds of our students to work their way through. Don't let money keep you away. If you have ambition you can do it. Resolve right now to put it over. Write us now for all the facts.

Learn Drafting

Every electrical student is taught electrical drafting. We also have special courses in all branches of drafting for those who want to specialize in this big paying splendid profession. We will train you EITHER HERE AT SCHOOL, OR AT YOUR HOME through our home study department. Expert draftsmen make from \$60 to \$200 a week. Check the coupon and send it now for special catalog.

Motion Picture Operating

We teach this attractive branch of the electrical profession in thoroughly equipped projection rooms; train you for Chief Operator, with salary from \$40 to \$75 a week, often for evening work only. Check and mail the coupon for special catalog.

Send Today for Big Free Book

Write today, *now*, for the book. It tells what Coyne graduates have done, what you can do. Fill in the coupon, check the trade you are most interested in or send a postal card. Do it *now*.

COYNE SCHOOLS

Dept. 2-Y

39-51 E. Illinois St. Chicago, Ill.

Send me your big free book and particulars of the course I have checked off below.

- Electricity
- Drafting, School Course
- Drafting, Home Course
- Motion Picture Operating

MAIL-COUPON FOR FREE BOOK NOW!

Name

Address

MAGAZINE Prices Slashed

Millions

of magazine subscriptions expire this month! With the tremendous advance of paper prices and labor it is certain that nearly all magazines will advance their subscription prices at least from 25% to 50%.

BY ORDERING NOW YOU WILL SAVE BIG MONEY.

In announcing these wonderful prices it is with the absolute knowledge that our readers are offered the lowest prices for standard Magazines that it is possible to obtain anywhere. Only by special arrangement with the publishers are these prices possible, but to take advantage of them, you must act quickly. Don't delay, do it now. This offer is so good that of necessity it must be limited in time. Just think of buying standard Magazines at reduced prices in time for Xmas Presents, and they certainly make ideal gifts being a constant reminder for a whole year of a considerate friend. Just glance over our wonderful prices, and see how we enable one dollar to bring you two dollars' worth, and then make up your list. When sending your order, don't forget to state where magazines are to be sent. But be sure you do it now. To-morrow means you may forget and lose this wonderful opportunity. All prices quoted are for subscribers in U. S. A. only, Canadian and Foreign subscriptions require additional postage.



*The
Publishers
Will Mail the
Magazine
Direct From
Their Own
Office to You.*

Science & Invention ... \$3.00	Our Price
Popular Science..... 3.00	\$5.75
Regular Price \$6.00	
Science & Invention ... \$3.00	Our Price
Scientific American.... 6.00	\$11.50
Illustrated World..... 3.00	
Regular Price \$12.00	
Science & Invention ... \$3.00	Our Price
American Magazine... 2.50	\$7.25
Woman's Home Comp'n 2.00	
Regular Price \$7.50	

Science & Invention ... \$3.00	Our Price
Etude for Music Lovers. 2.00	\$4.50
Regular Price \$5.00	
Science & Invention ... \$3.00	Our Price
Everybody's Magazine.. 2.75	\$8.00
Delineator 2.50	
Regular Price \$8.25	
Science & Invention ... \$3.00	Our Price
McCall's Magazine..... 1.50	\$3.50
Regular Price \$4.50	

Science & Invention ... \$3.00	Our Price
Today's Housewife 1.00	\$3.50
Regular Price..... 4.00	
Science & Invention ... \$3.00	Our Price
Wireless Age..... 2.50	\$6.75
Radio News 2.00	
Regular Price \$7.50	
Science & Invention ... \$3.00	Our Price
Boys' Life 2.00	\$4.50
Regular Price \$5.00	
Science & Invention ... \$3.00	Our Price
Illustrated World..... 3.00	\$7.25
Radio News..... 2.00	
Regular Price \$8.00	
Science & Invention ... \$3.00	Our Price
Field and Stream..... 2.50	\$5.25
Regular Price \$5.50	

For computing together Magazines listed separately, add Class Numbers before title and multiply by 5, giving our price to you in dollars and cents.

Write for Special Prices on ANY Publication not listed here.

We will save you money

Special Clubbing Prices of Science and Invention WITH:

Club No.	Magazine	Regular Price	Our Price	Club No.	Magazine	Regular Price	Our Price
80	Adventure ...	\$4.00	\$6.75	37	Modern Priscilla.	\$2.00	\$4.60
50	American ...	2.50	5.25	60	Munsey's Mag'zn	3.00	5.75
35	Boys' Life ...	2.00	4.50	30	McClure's Mag'zn	1.65	4.25
35	Christian Herald	2.00	4.50	70	Outing	4.00	6.25
80	Cosmopolitan .	4.00	6.75	50	Pictorial Review	3.00	5.25
100	Country Life... 5.00	7.75		60	Popular Science.	3.00	5.75
75	Current History	4.00	6.50	35	Radio News. . .	2.00	4.50
50	Delineator	2.50	5.25	120	Scientific Am'n.	6.00	8.75
40	Designer 2.00	4.75		70	Smart Set.....	4.00	6.25
55	Everybodys ... 2.75	5.50		15	Today's Housewife	1.00	3.50
35	Etude (for Music Lovers) ...	2.00	4.50	45	Wireless Age ...	2.50	5.00
50	Field & Stream.	2.50	5.25	40	Woman's Home Companion... 2.00	4.75	
60	Garden Mag'zne	3.00	5.75	50	Youth's Comp'n	2.50	5.25
55	Illustrated World	3.00	5.50				

SEND ALL ORDERS TO "CIRCULATION DEPARTMENT"

EXPERIMENTER PUBLISHING CO., Inc.
233 Fulton Street, New York City, N. Y.





\$186 IN 2 WEEKS
 EARNED BY A BURGESS-TRAINED MAN

READ THIS LETTER
 From the Chief Electrical
 Engineer of a Large

Industrial Corporation

Dear Sir:
 "One of your students, who has charge of half of the motors in our shop, received \$186.05 for two weeks' pay a short while ago. To my recollection, this is the largest amount ever drawn by a man in this position and I must say it speaks well for you and the service you render."

(Name on request.)

ELECTRICITY

BY A PRACTICAL MAN
 TAUGHT BY A PRACTICAL MAN
 A Home Study Course

MY POLICY

My policy is TRUTHFULNESS in advertising and to give an HONEST and RELIABLE SERVICE. I offer NO FREE INDUCEMENTS but I promise to give you INSTRUCTION, HELP and ADVICE, the kind that is helping hundreds of men and boys to succeed. In other words, my policy is to B² (be square).

YORKE BURGESS, Supt.
 Burgess Electrical School
 745 E. 42nd St. Chicago, Ill.

BEGINNERS GET ELECTRICAL JOBS

After Taking the Burgess Course a Short While

A FAIR AND SQUARE STATEMENT

I have been training ambitious men, both young and old, in practical electricity for a number of years by my Home Instruction Method, and would like to send you my catalog, which tells exactly what I do and **HOW I DO IT**. It also tells why, when and where my students succeed and **HOW THEY DO IT**. The catalog costs you nothing—it obligates you in no way whatever, but, for your own good send for it, as it contains things you should know.

WHY THE BURGESS COURSE AND SERVICE WERE STARTED

During my engineering experience I found that it was hard for an earnest young fellow to get into the electrical game right and it was hard for a man in the game to make the progress he desired. I looked into the reasons for this situation and found what was needed. To remedy this condition is the purpose of the Burgess Course and Service, and they are today filling a much needed want. Furthermore, our standing is built upon what we have actually done, not what we claim to do. I do not promise you \$500.00 PER MONTH, or that you will be able to qualify as an **ELECTRICAL ENGINEER** in a few months. As a matter of fact, some of those I have taught are getting and earning more than \$500.00 per month and there are **ELECTRICAL ENGINEERS TAKING MY COURSE** at the present time. However, what you get in the way of money, or whether you become a **WATER-BOY** or **ELECTRICAL ENGINEER**, depends in a great measure on you. You will admit this if you think a minute. What I do say is, that if you will do your part by following my instruction and advice, I will help you get into the electrical business if you wish to get into it, and if you are in it, I will supply you with information and help which will push you along faster. Zillman McNamara of Denmore, Kansas, wrote me one day, "YOUR COURSE MAKES A MAN STAND ON BOTH FEET." He expresses in a very few words exactly what I aim to do.

COMPLETE ELECTRICAL OUTFIT

Including Apparatus, Tools and Material, is supplied with the course without extra charge.

INSTRUCTION

The instruction is no cut and dried book plan, but is actually prepared with a view of fitting the individual. In this way one who is slow has the same advantage as others. The course covers the various subjects from simple dry cells to hydro-electric operation, particular effort being made on the really practical things and the things men need in their everyday work, such as—storage batteries, wiring calculations, automobile systems, farm lighting systems, motor applications, motor installing, motor testing and repairing, armature winding transmission and power plants.

ELECTRICAL DRAFTING

Every A No. 1 Electrical man understands how to read drawings, and I find that the best way to teach him this is to teach him how to make them. Thus—the reason for my drafting course. This is a part of the regular work and certain drafting implements and materials are furnished students without any additional charge.

ELECTRICAL SLIDE RULE

As a thorough knowledge of the slide rule is so necessary in our business, I have written 30 lessons on this subject which are now included as part of the regular course in addition to the lessons on Electricity and Drafting. I am also supplying a Slide Rule and leather case to each student without charge.

FIFTY-FIFTY

It is odd, but true, that the most astonishing thing about my business is the way in which it is handled. I actually do handle the instruction work myself, and I see to it that **A STUDENT GETS WHAT HE WANTS. HE PAYS ONLY FOR WHAT HE GETS.** That is 50-50. Furthermore, every student enrolls with the understanding that if he should have to discontinue for any reason, his payments stop also. That is some more 50-50.

If you are one of the "LET'S GO" Type of fellows, send for my catalog and see the results my men are getting by studying at home, backed up by BURGESS SERVICE. Write your name and address plainly on coupon so there will not be any delay in the catalog getting to you.

YORKE BURGESS, Supt.

BURGESS ELECTRICAL SCHOOL

745 East 42nd Street

Chicago, Illinois

"ELECTRICAL HAND BOOK"

THE "Burgess Blue Book" contains drawings and diagrams of Electrical Machinery and Connections—Starting Boxes, Elevators, Controllers, Starters for Printing Press Motors, Street Car Controllers, Transformer Connections, Lighting Circuits.

The section on Calculations takes up Simple Electrical Mathematics, Wiring Tables, Alternating Current Calculations, etc. It also gives 200 formulas, with problems worked out, showing their application.

Price \$1.00. If you decide not to keep it, your money will be returned

THE BURGESS COMPANY

YORKE BURGESS, President
 Consulting Electrical Engineering

750 East 42nd Street Chicago, Illinois
 Power Plants, R.R. Signals, Electric Railroads, Motor Troubles and Industrial Problems. Information Furnished on Electrical Subjects. Inventions and Patents Perfected.

YORKE BURGESS, SUPT.
 Burgess Electrical School, 745 East 42nd Street, Chicago, Illinois.

DEAR SIR:
 Please send me your catalog "C," which explains your Home Instruction Course and the Burgess Service Method.

Name.....
 Address.....

SPECIAL BARGAIN SALE

MOTORS

MOTORS
1/16
H.P.
\$7.50

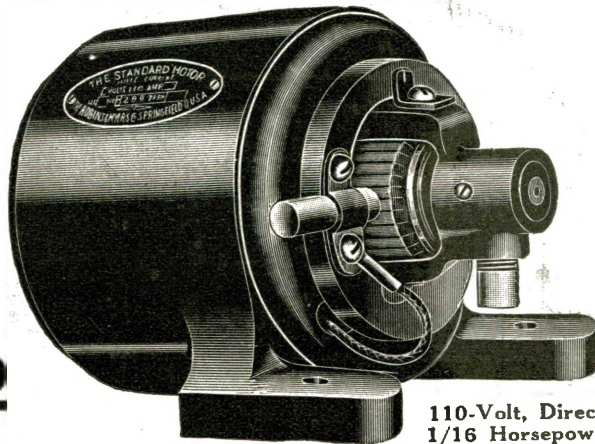

*SPECIALLY
 SUITABLE
 FOR*

**ROTARY
 SPARK-GAPS**

BIG BARGAIN

110-Volt, Direct Current,
 1/16 Horsepower Motor

1/16 H.P. MOTORS

SPECIFICATION

Enclosed type, practically dust proof. Shunt wound. Motor reversible. Constant speed. Carbon brushes. Oil cups—self-regulating. Extra fine commutator, made up of 32 segments. Speed 1,800 R.P.M. Bi-polar type machine.

No pulley. Size over all 4 1/4 x 5 x 6 1/2 in. Black Japan finished casing. Shipping weight 15 lbs.

Our Price

\$7.50

As long as they last

Built for the Government by

Robbins & Myers

Slightly used, but we guarantee them to work perfectly. These splendid, powerful little motors sell, elsewhere, for from \$15 to \$20. Don't hesitate to take advantage of this unheard-of low price, at once. Send your order today.

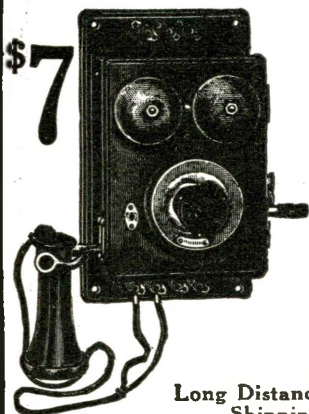

For Homes, Offices, Factories, Farms

Complete Wall Set Magneto Telephone

Western Electric Type

This is a complete commercial telephone station. They were bought from telephone exchanges who put in Central battery types. Slightly used but guaranteed to be in A1 working order.

Will work perfectly at all distances up to 20 miles.

Long Distance Telephone Set— One station
 Shipping weight, 15 lbs. **\$7.00**

Two stations
 Shipping weight, 25 lbs. **\$13.00**

WIND YOUR OWN HIGH- OHMAGE RECEIVERS



This wire, which is so fine that over 45,000 feet go in one pound, is used for all high grade Wire-less Receivers. We have only the following few spools left over. Order at once. First come, first served.

No. 44 B. & S.
 Enameled Wire

		Weight—Hundredths of lbs.														
		40	36	14	39	38	28	49	34	29	30	36	18	46	22	43
Amt.	\$9.20	\$8.28	\$3.22	\$8.07	\$8.74	\$6.44	\$11.27	\$7.82	\$6.67	\$6.90	\$8.88	\$3.68	\$10.58	\$5.06	\$9.89	

Don't send any Money! Simply select the spool wanted and we will send it, or the next in size, C. O. D.

Remember as always in our sales: *First come, first served.*

Add Postage or we will Send by Express Collect

IMMEDIATE SHIPMENTS!

The Electro Importing Co., 231 Fulton Street, New York

FREE!

You can have this complete set of books free a whole week. Don't send us a penny until you are satisfied they are exactly what you want.

Mail the Coupon Now!

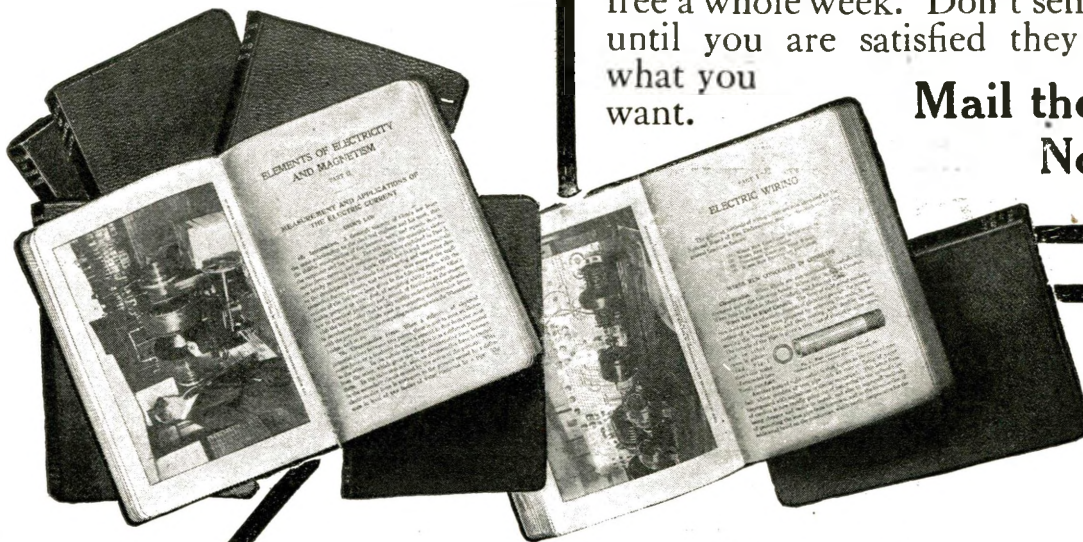

Learn How to be a **BIG PAY ELECTRICIAN**

Why spend months, even years, in school—paying out good money for board and tuition—when the master minds of the electrical world tell you everything about electricity in this brand new electrical library, just off the press? Men who know the science from practical experience point the way to success in this wonderful field. You can use your spare time and the

Cyclopedia of Applied Electricity

to advance you to a pleasant, big-paying position in a very short time. These books contain no higher mathematics to wade through. Nothing but plain, everyday English and figures anyone can understand—they represent a home study course that

Makes Things Simple as A, B, C

Think of it—eight wonderfully interesting volumes just crammed full of electrical facts. But seeing is believing, so take advantage of our seven days' free trial offer. Then if you decide to keep the books, pay a little each month. Mail the coupon today!

American Technical Society

Dept. E-259, Chicago, U. S. A.

Send No Money! Just Mail This Coupon

27 Experts Show the Way YOU GET THE FACTS

When you want to know all there is to know about any electrical subject—

When you want to know the newest and best ways to do things—

When you want a big paying electrical job—
You can place full faith in this great Electrical Library.

This Coupon May Solve Your Future

One small advance in your weekly pay will make them an investment paying big returns. Think—can you afford to be without these books?

AMERICAN TECHNICAL SOCIETY

Dept. E-259, Chicago, U. S. A.

Please send me the eight-volume library of Applied Electricity for seven days' free examination, by express collect. I will either send you \$2.80 within a week as first payment, and \$3.00 each month until \$34.80 is paid, or return the books at your expense. If I keep the books I am entitled to a \$12.00 one-year membership in your Society free.

Name

Address

Reference

HOW CAN I MAKE SOME MONEY?

BREED CANARIES

Profitable Pastime. Particulars Free. **THE BIRD FARM,**
Lynnhaven, Virginia

The above advertisement, which has appeared in Newspapers and Magazines for the past seven years, has induced thousands to permanently coin their spare time into a profitable pastime. If you want to operate the pleasantest, most interesting and most profitable spare time business under the Sun, which may result in a life income for you; if you want to turn wasted hours into golden ones, embrace this opportunity, and answer this advertisement at once.

THE BIRD FARM

LYNNHAVEN

VIRGINIA

An Oldfashioned Southern Institution with Ideals, where Honesty and Fair Dealing are Paramount.

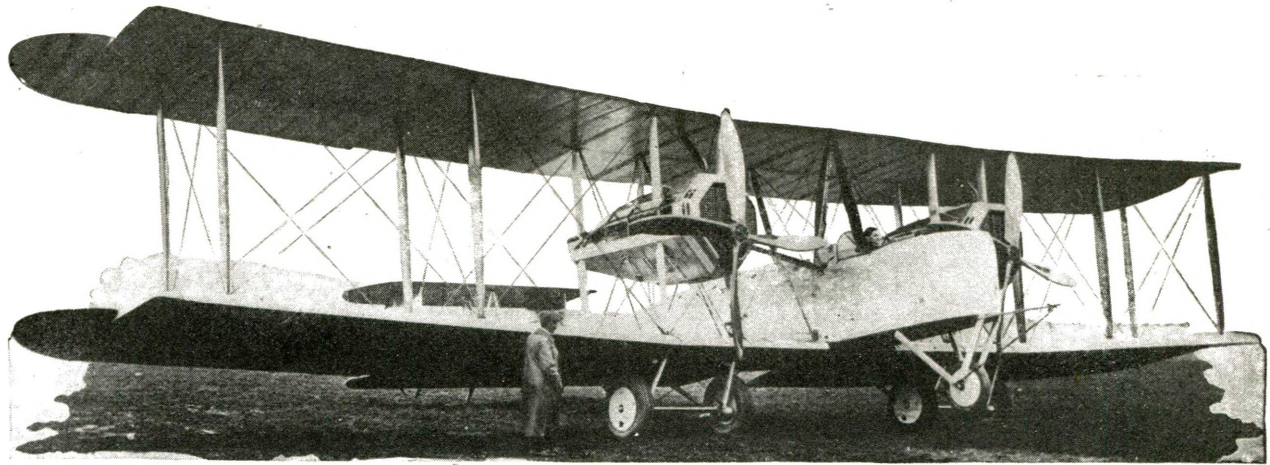

Go as High as You Like No Limit to Salaries in Aviation

No other industry offers the wonderful chances for big money-making that the Airplane Industry offers to ambitious men today. Trained men are needed immediately to fill big paying jobs. The airplane has come to stay—it will soon be a part of our everyday life. The men who get in now are the ones that will cash in big. Look at the “big fellows” in the automobile game today. They represent power and wealth because they got in early—you can do the same in aviation and you have an advantage because you can be trained before you start.



Delivering Newspaper "Extras" by Airplane



A New Seven-Passenger Airplane

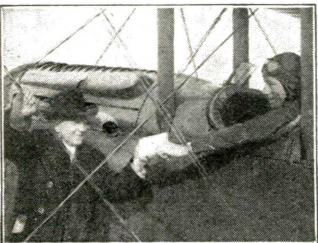

A New Job—The Aerial Postman



View in an Airplane Factory

Thousands of Airplane Mechanics Needed

Airplane factories are being built by the dozens. Transportation, passenger carrying, and mail carrying lines are being opened up everywhere. This means men, men, men. Trained men only are wanted—men who know what's what. Ten times the number of men now engaged in this work are needed. Jobs with big pay are waiting for men to fill them just as soon as they are trained. Why don't you prepare for one of these big jobs now?

Here Are a Few Jobs That Will Pay \$50.00 to \$250.00 a Week:
 Aeronautical Instructor Aeronautical Engineer Aeronautical Contractor Airplane Repairman
 Airplane Mechanician Airplane Inspector Airplane Salesman Airplane Assembler Airplane Builder

Learn at Home In Your Spare Time

is simplified for home instruction and is endorsed by airplane manufacturers, aeronautical experts, aviators and the leading aero clubs. Any man that can read English can understand it. The Lessons are self-explanatory and are made plain as day with Blueprints, Diagrams, etc. Our Advisory Council and Instructors are behind you all the time giving you everything you must know. The entire field of Practical Aeronautics and Science of Aviation is laid right before your eyes. You are bound to succeed with this training. This means for you a man's size job with a man's size pay.

Big Book of Opportunities FREE!

Send for our big free book showing just what is going on in the Airplane Industry. It also shows what other men have done in this fascinating field and what you can do, too. It gives a list of some large manufacturers and dealers in airplanes and some of the jobs that are open to trained men. With the book we will send you a special offer that you will be glad to know about. This special offer may be withdrawn at any time without notice. *Send the coupon now and take advantage of this offer.*

American School of Aviation
 Dept. 7449 3601 Michigan Ave. Chicago

Keep right on with the work you are doing now. A little of your spare time is all you need. Our Special Course



Mail This Coupon For FREE BOOK

Name.....
 Address.....
 City..... State.....

AMERICAN SCHOOL OF AVIATION
 Dept. 7449
 3601 Michigan Ave. Chicago

Without obligation on my part you may send me your book entitled "Opportunities in the Airplane Industry" and your SPECIAL Limited offer.



Master Electricity By Actual Practice

The only way you can become an expert is by doing the very work under competent instructors, which you will be called upon to do later on. In other words, *learn by doing*. That is the method of the New York Electrical School.

Five minutes of actual practice properly directed is worth more to a man than years and years of book study. Indeed, Actual Practice is the only training of value, and graduates of New York Electrical School have proved themselves to be the only men that are fully qualified to satisfy EVERY demand of the Electrical Profession.

The Only Institution of the Kind in America

At this "Learn by Doing" School a man acquires the art of Electrical Drafting; the best business methods and experience in Electrical Contracting, together with the skill to install, operate and maintain all systems for producing, transmitting and using electricity. A school for Old and Young. Individual instruction.

Over 6,500 Graduates are Successful Men in the Electrical World

No previous knowledge of electricity, mechanics or mathematics is necessary to take this electrical course. You can begin the course now and by steady application prepare yourself in a short time. You will be taught by practical electrical experts with actual apparatus, under actual conditions.

The N. Y. E. S. gives a special Automobile Ignition Course as an advanced training for Auto Mechanics, Garage Men and Car Owners. The course covers completely all Systems of Ignition, Starters, Lighting and other electrical equipment on automobiles, motor boats, airplanes, etc.

Let us explain our complete courses to you in person. If you can't call, send now for 64-page book—it's FREE to you.

New York Electrical School

29 West 17th Street, New York

New York Electrical School
29 W. 17th St., New York, N. Y.

Please send FREE and without obligation to me your 64-page book.

..... NAME
 STREET
 CITY STATE

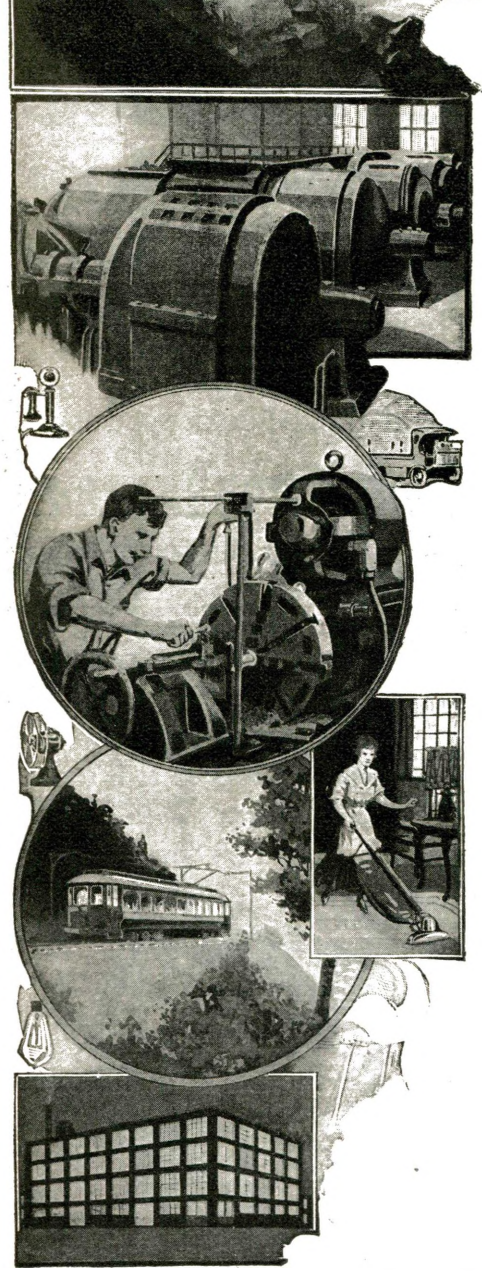

H. GERNSBACK - EDITOR
H.W. SECOR - ASSOCIATE EDITOR

Floating Sunken Ships

NOT only were hundreds of ships sunk by torpedo attacks and shell fire during the progress of the World War, but there are many other wrecks which have lain on the bottom of the sea for years, some of which contain considerable wealth in the form of bullion and coin.

How Submerged Electric Pumps, Compress Air and Huge Pontoons are Raising Sunken Ships

is shot down thru tubes of steel and rubber into the bowels of the sunken ship—the deck hatches and other openings having been previously closed and tightened down thoroly by divers.

The first sunken wreck to be raised by this method of compress air, was the *S. S. Royal George*. By the aid of divers and

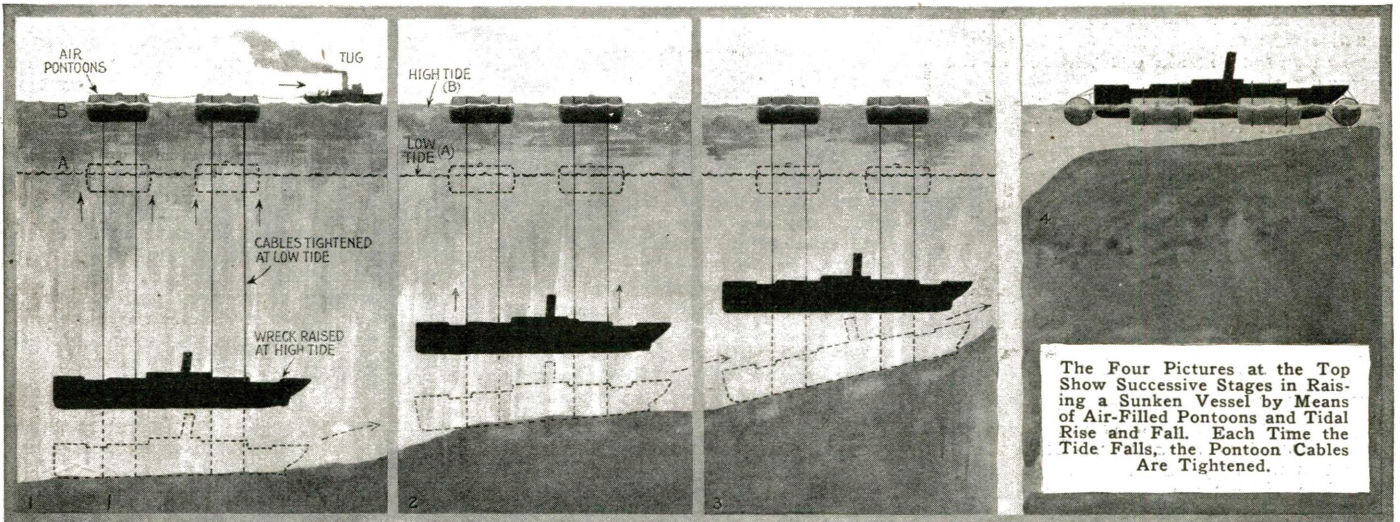

The Four Pictures at the Top Show Successive Stages in Raising a Sunken Vessel by Means of Air-Filled Pontoons and Tidal Rise and Fall. Each Time the Tide Falls, the Pontoon Cables Are Tightened.

The Scheme for Salvaging Ships by Means of Compress Air Shown at the Right, Has Been Successfully Carried Out. The Compress Air Is Shot Down into the Ship's Hold, Which Has Been Made Air-Tight by Divers, Driving the Water Out Thru the Opening Which Previously Admitted It. A Flexible Patch Is First Lowered Over the Rent from the Outside, as Shown. The Rent Is Then Repaired by Men Working Under Air Pressure.

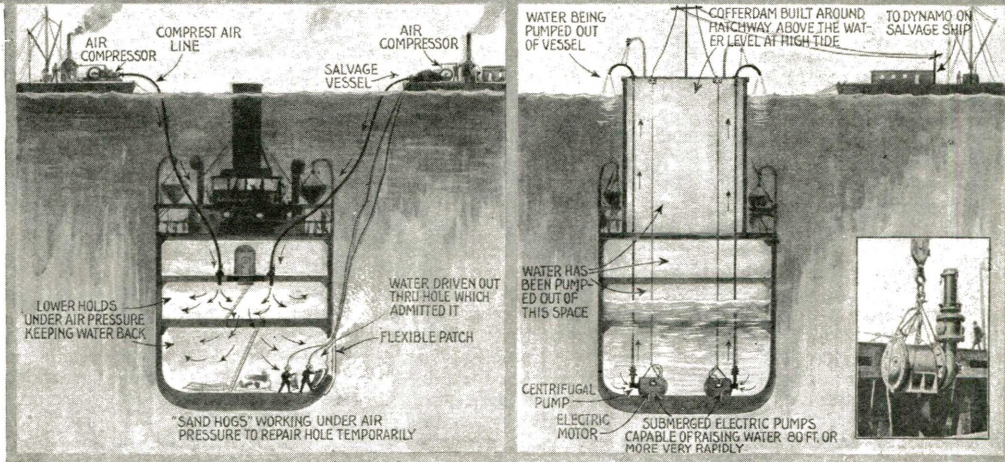

In the Successfully Tried Scheme Shown at the Left, Cofferdams Are Built Directly Over the Large Hatchways in the Ship's Deck. Powerful Submergible Electric Pumps Are Lowered Down into the Hold of the Vessel and the Water Is Pumped Out from the Cofferdam and the Lower Hold, and the Ship's Buoyancy Finally Re-established, Causing the Ship to Rise. Any Rents Are First Covered with Patches or Otherwise Taken Care Of.

Salvage experts, the world over, have become awakened to the fact that a fortune awaits those who will conceive successful schemes for salvaging the hundreds of vessels which were sunk in various European waters, not to mention many dozens of ships which were sunk off the American coast from time to time, either by accident or otherwise.

The accompanying illustration shows three very interesting and practical inventions which have been successfully applied in a number of instances for the salvaging of sunken ships. These include three striking and logical applications of the

"laws of Nature," plus mechanics, compress air and electricity.

Floating Ships by Compress Air.

One of the most spectacular and surprising methods of floating submerged ship hulls, particularly to the layman, is that involving the use of compress air to render buoyant all or the major portion of the vessel's hull.

One of the accompanying illustrations shows how compress air applied from powerful compressors, driven by steam or gasoline engines carried by the salvage craft,

experts in this class of work, the decks were suitably strengthened and all hatchways and other openings closed. Suitable air locks were installed as shown in the illustration to enable the *sand hogs* (that is, men who are accustomed to working in a compress air atmosphere), to gain entrance to the lower holds of the vessel.

In many cases, including the present one, the outside rents are covered as accurately as possible with large flexible blankets braced by steel and wooden beams, known as patches. The compress air when shot down into the lower hold compartments of

(Continued on page 929.)

Einstein Theory and the Fourth Dimension

By H. GERNSBACK

Member American Physical Society

VOLUMES have been written during the past few months about the now famous Einstein theory of relativity and the fourth dimension. As for the latter, this is not a new subject, having long appealed to the delvers into the occult and to adherents of spiritism, as well as those who reason solely by metaphysics.

Thus, for a long time students of the fourth dimension had an entirely different conception from what physicists think it today. In their earlier fourth dimensional world, for instance, it was thought possible that you could turn an orange inside out without breaking its skin. Or you could remove a patient's appendix without making an incision in him. In other words, among many other similar absurdities, they thought that in the fourth dimensional state every three dimensional body could be turned inside out the same as you turn a glove or a sock inside out without in the least damaging it.

Since Einstein has appeared on the stage, however, this trend of thought has disappeared, and our present conception of the fourth dimensional world—if indeed it exists—is totally different from the old concept. We will, however, come back to this later.

In order to become better acquainted with the Einstein theory, let us first cite the fundamental experiment upon which his researches are based.

About Relativity

The velocity of light which is about 186,000 miles per second is unaffected by the movement of its source. Let us first make this plain by an analogy.

If a man in a train going sixty miles an hour throws a ball in the same direction as the train, and at the same speed, the velocity of the ball in relation to the earth is 120 miles an hour. Suppose this ball was thrown from the engine towards the rear. Then the velocity of the ball in relation to the earth would be zero, and if the ball was thrown from the rear platform, it would drop vertically to the ground. This is a simple example of *relativity*; this expression means that *the movement of the ball is relative to the train, as well as relative to the earth.*

Now consider a ray of light. Here an entirely different phenomenon takes place. It makes no difference whatsoever if we have a searchlight mounted on the locomotive of a moving train throwing the light backward, or if we have the searchlight on the last car of the train throwing the light forward with the train. *The speed of the light is absolutely unaffected by such motion.* Not only is this true for the light placed on a moving object, but it is also true for an observer stationed on the ground. Strange as it seems, the speed of the light ray either coming toward him or moving away from him is not at all affected by the speed of the train which carries the searchlight. This statement may be readily proved by the regularity of the apparent motion of several moons of some of our planets, as, for instance, the moons of Jupiter. At one part of their orbit these little moons are moving away from us, while at the opposite part of the orbit they are moving toward us. Yet they appear absolutely regular in their motion, proving that light coming from their surface takes the

same time to reach the observer on earth whether the little moon advances or recedes from us.

If this were not so, the motion of the satellite would be irregular at all times. It might even happen that it would seem to move backward. This brings us to the famous Michelson-Morley experiment. This was originally based on the fact that light has the same velocity irrespective whether its source moved or was fixed.

To elucidate: Light for a long time has been thought to be merely a wave motion in the ether. This ether is supposed to surround us, filling the most minute interstices of all matter and, therefore, it must permeate the earth as well. Thus the earth is supposed to be entirely merged into this ether. Consequently, either of two things must happen, which we put in the form of

THERE are few subjects so difficult to explain in simple language as the Einstein theory and the fourth dimension. The present article, which covers the more important phases of the Einstein theory, aims to instruct the reader in a popular way and in plain English devoid of all technicalities. We believe little difficulty will be found even by the average school-boy in understanding the subject. In an article of this kind, it is of course not possible to cover all of the various phases without going into mathematics, and for that reason such phases have been covered by means of analogies as much as possible. It should be noted that the views expressed by the author are those held by most physicists today. But as there is very little known on such subjects as, for instance, light, gravitation and space, it is quite likely that our present-day views will be modified from time to time. This is the first time that the Einstein theory and the fourth dimension have been explained in a strictly popular, non-technical manner, and we hope our readers will appreciate the present effort.

questions. First, as the earth is speeding in its orbit around the sun, does it pass thru the ether without disturbing it as, for instance, a fine wire-mesh sieve passes thru water? And, if so, does it produce a sort of vortex or disturbance in the ether as it rushes thru it? Second, does the earth push thru the ether as a train pushes thru the atmosphere, leaving behind it a sort of ether whirl and partial vacuum, just as the train leaves behind it a whirling eddy of air and partial vacuum?

The Michelson-Morley Experiment

This question the Michelson-Morley experiment was supposed to solve. A light ray being a wave motion in the ether, it was naturally thought that a ray of light going in the direction of the earth should naturally move a trifle faster than a ray of light shot against the motion of the earth or at right angles to it. Then if there was a sort of *ether-drift* produced by either of the reasons mentioned above, accurate instruments would be enabled to detect the slight difference in speed. The famous Michelson-Morley experiment was origi-

nally based upon the fact that light has the same velocity, irrespective of the movement of its source. A ray of light was sent out to a mirror occupying a plane parallel to the motion of the earth, so as to go out and be reflected back to the observer. A second ray was sent out at right angles to this one in the direction of the terrestrial motion, also to be received by a mirror and reflected back. The plane of the first mirror was arranged by measurement, at the same distance from the observer as that of the mirror for the other ray of light.

The diagram, Fig. 1, shows the path pursued by the two rays. One path is an isosceles triangle, whose base is the space moved over by the observer during the passage of light from its source to the mirror and back to him. At right angles thereto, is the path of the second ray, which has to catch up with the mirror moving away from its source, and is reflected back again to the observer. The effect of all this, is that the rays will pass over paths of different lengths, and it was anticipated that they would reach the observer at different periods of time, one ahead of the other. This is what was anticipated as the result of the experiment which was intended to be a very convincing demonstration of the fact that the earth was moving thru space. But when the experiments were tried, nothing of the sort occurred, so that apparently *the longer path was traversed by the light in exactly the same time as was the shorter one.* So scientists were called upon to explain what other causes there might be to produce this paradox. This led to the so-called Lorentz-Fitzgerald contraction theory. These scientists came to the conclusion that as there is no measurable difference in the speed of light in the above experiments, this could only be accounted for by having the earth shrink just sufficiently to account for the difference. In other words, as the earth moves forward in its path, due to its tremendous speed, viz., 65,533 miles per hour, it shrinks just a sufficient amount (about three inches) to account for the missing difference. In plain English, if we take a body and move it at a tremendous speed forward, *it shrinks in the direction of its axis* for a small amount, this amount increasing as the speed of the object is increased.

The Speed of Light

Now it must be made plain right here that in order to shrink at all, these speeds must be quite tremendous, and as far as we human beings are concerned, our everyday lives will probably never be affected. In its axial rotation the earth revolves at a speed of 1,039 miles an hour. Low as this speed is compared to 65,533 miles per hour of the earth's speed in its orbit around the sun, such speeds are never encountered on earth, as far as large bodies are concerned. Even our fastest projectiles, moving faster than anything known on earth, fall far short of this speed. But it has been maintained that a projectile shot from a cannon shrinks or rather contracts for a small fraction of an inch, which can be calculated. It should be understood right here that this shrinkage or contraction has nothing whatsoever to do with the air resistance. As is well known the earth moves in a perfect vacuum; yet modern scientists
(Continued on page 890)

EINSTEIN THEORY AND FOURTH DIMENSION

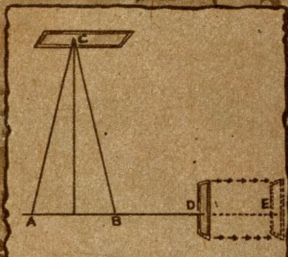

A POINT WHERE LIGHT ORIGINATED
B POINT WHERE LIGHT REFLECTED
FROM MIRROR 'C' IS RECEIVED
D MIRROR IN FIRST POSITION MOVING
TO 'E' BEFORE THE LIGHT FROM 'A'
IS REFLECTED BACK TO 'B'

FIG. 1

The Michelson-Morley Experiment. Was Based on the Fact That the Velocity of Light is Unaffected by the Motion of the Source Whence it Emanates. The Result of the Experiment Was Negative.

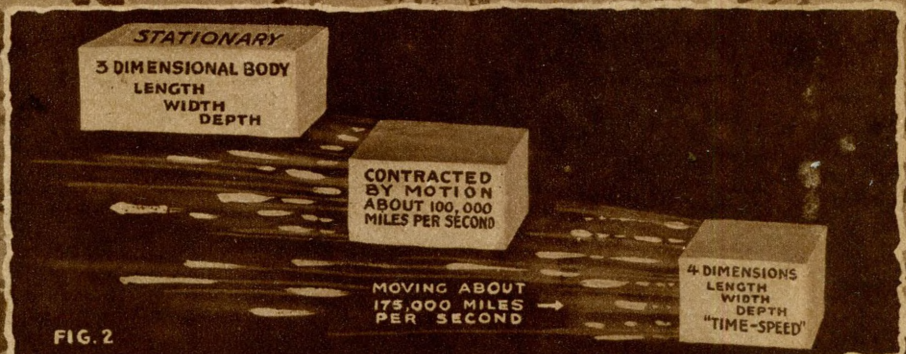
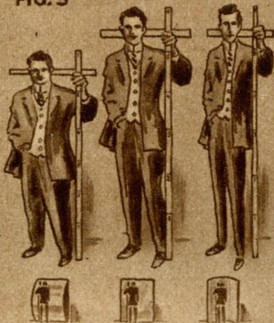

FIG. 2

A Modern View of the Fourth Dimension. It Asserts That if We Project a Three Dimensional Body Into Space at Tremendous Speeds, Such a Body is Reduced in Length, in the Direction of its Axis of Motion, According to the Lorentz-Fitzgerald Contraction Theory. It Would, However, be Impossible to Measure Such a Contraction Because Our Measuring Instruments Would Contract in the Same Ratio as Shown in Fig. 3.

FIG. 3



An analogy of the Lorentz-Fitzgerald contraction theory. The man with his measuring sticks shrinks or is lengthened by the curved mirrors. It is impossible for him to know the REAL length of the stick by looking into the curved mirrors.

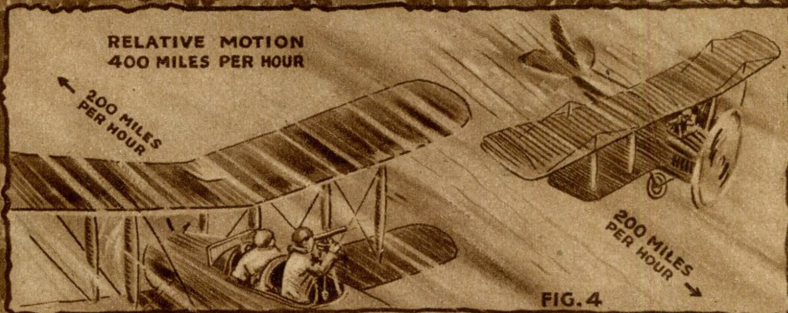

FIG. 4

A Study in Relativity. The two Airplanes Going at 200 Miles Per Hour in Different Directions Give Us 400 Miles of Relative Motion. This is Relativity. According to Einstein, It is Impossible for Either of the Two Aviators to Tell at What Absolute Speed the Opposite Airplane is Moving, No Matter What Instruments He Uses.

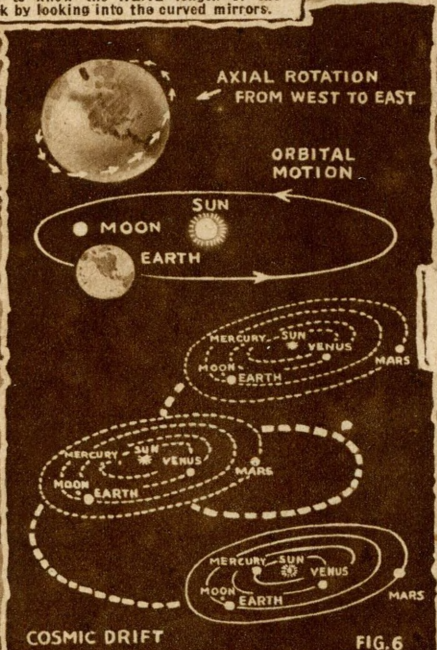

FIG. 6

A Further Study in Relativity. The Earth Revolves at 1039 Miles an Hour Equatorial Velocity in its Axial Rotation. At the Same Time it Speeds Around the Sun Due to its Orbital Motion at the Rate of Over 65,000 Miles an Hour. This is Not All. The Entire Planetary System Moves in a Sort of Huge Spiral, Termed Cosmic Drift, as Shown.

TRAIN AND SHIP, THO ACTUALLY GOING WEST, ARE CARRIED BACKWARD TO EAST



FIG. 5

If You Take a Train From New York to Chicago, You Believe That You Are Going West. You Do Nothing of the Sort. You are Going East Many Times Faster Than You Go West, Because the Earth Revolves From West to East Carrying the Train "Backward." If Your Train Ran West Along the Equator at 60 Miles an Hour, It Would be Carried East 979 Miles an Hour, As the Velocity Due to the Earth's Axial Rotation is 1039 Miles an Hour at the Equator.

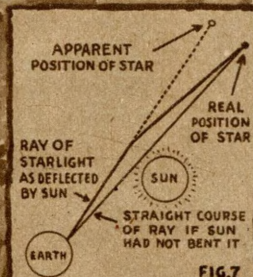

FIG. 7

How the Einstein Theory Was Confirmed. Light (Which Now is Thought to Have Substance) Coming From a Distant Star is Deflected by the Sun Due to its Gravitational Field.

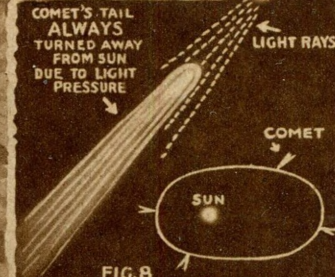
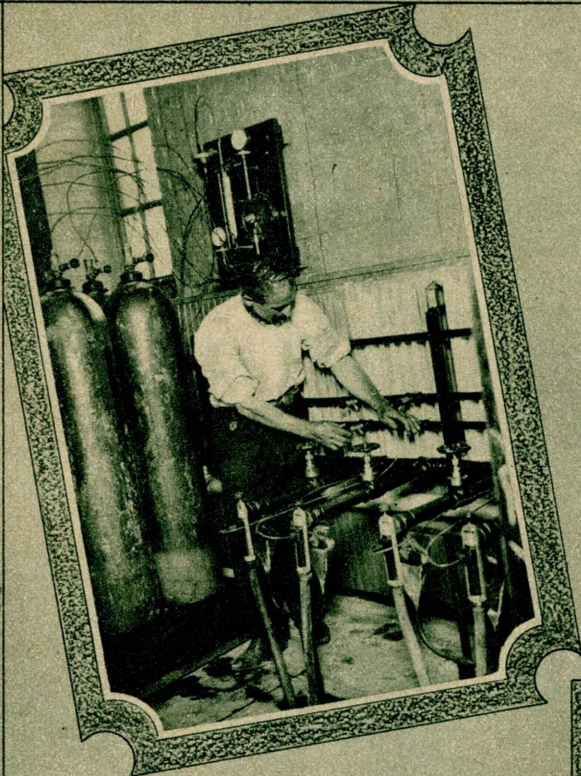

FIG. 8

Sunlight Exerts a Pressure of Over a Hundred Tons Upon the Surface of the Earth. This is Now Thought to be the Chief Reason Why the Tail of a Comet Always Points Away from the Sun.

SCIENCE



Applying Chlorine Gas at the Kensico Reservoir for Sterilizing the Water Supplied to New York City. The Gas is Received in Liquid Form Comprest in Cylinders. The Croton Supply is Treated Similarly and Smaller Plants in the Catskills and Croton Watersheds Treat the Streams Before Entering the Reservoirs.—(Copyright by Keystone.)

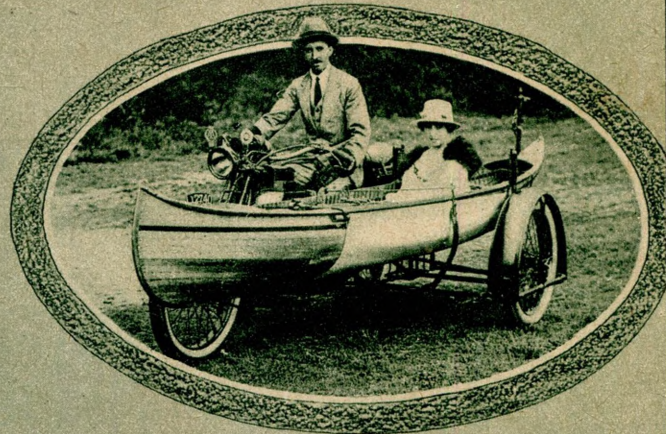

A Novel Motor-cycle Combination, Consisting of a Canoe Attached to a Motor-cycle in Place of the Usual Side-car. It Provides Ample Accommodation for Three People and is Easily Detached on Reaching the River.—(Copyright by Keystone.)



The Paddle Row Boat Worked by Pushing Lever Backward and Forward. No More Losing Your Oars. This Latest Invention Recalling the Canoe Paddle is Very Simple to Work With the Two Arms, Which Also Work Individually. They are Used as Pushers by the Lever in the Seat Not Only Making the Boat Go, But Serving as Good Exercise for the Back and Arms.—© Kadel & Herlet.

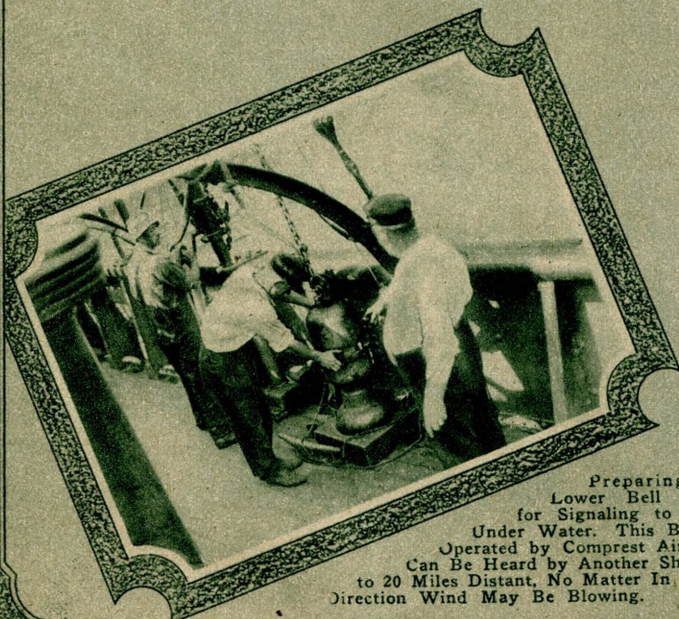

Preparing to Lower Bell Used for Signaling to Ship Under Water. This Bell is Operated by Comprest Air and Can Be Heard by Another Ship 15 to 20 Miles Distant, No Matter In What Direction Wind May Be Blowing.

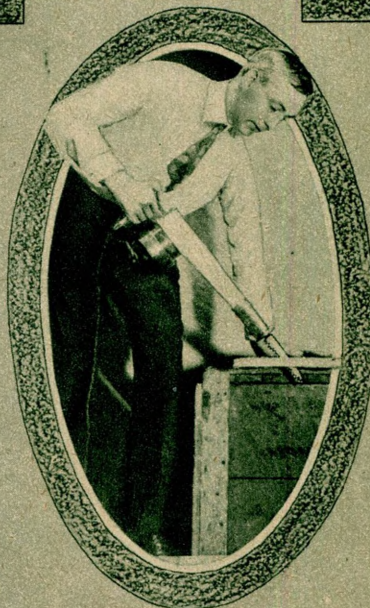

Invents Electric Hand Saw. Charles M. Geiger, of Chicago, Operating His Recently Invented Electric Hand Saw. The Saw, Operated by a Small Electric Motor, Will Facilitate the Arduous Labor of Sawing by Hand.

IN PICTURES

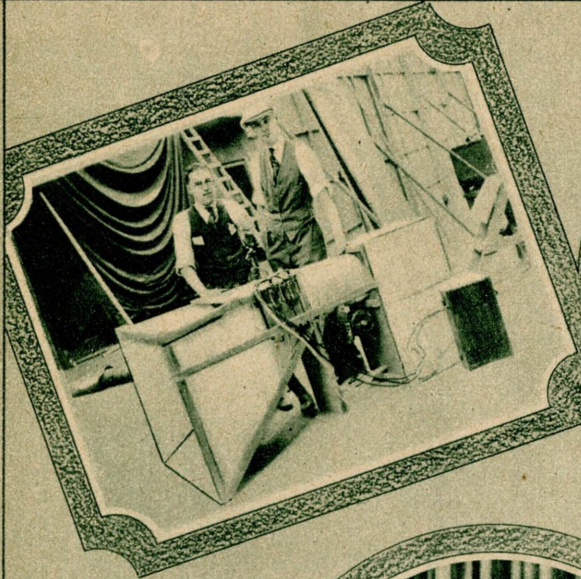

Inventors Doom the Movie Bug—the Little Pest that Flies Around the Bright Lights, and Has Spoiled Many Feet of Film. The Invention is a Bug-catching Machine, Consisting of a Wide Box, a Carbon Arc, 2000 Candle-power Lamps, a Funnel, a Suction Fan and a Large Net. The Bugs are Attracted by the Light, the Carbon Arcs Burn Them and the Suction Fan Draws them into the Net. In a Recent Test the Machine Netted Nearly 10 Pounds of Bugs in Less Than That Many Minutes. By Number the Total Haul Was Estimated in Excess of 12,000.

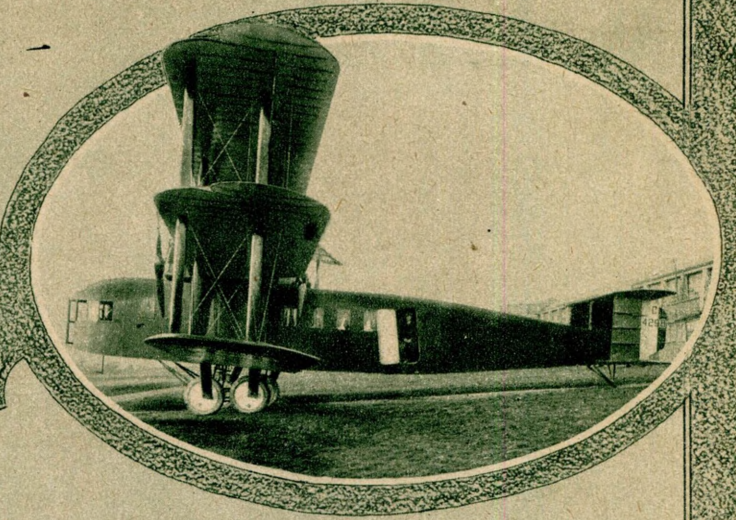

Above:—The Giant "Bristol Pullman" Airplane Built in England. It is Designed to Carry Pilot, Engineer and 14 Passengers. It is Powered With Four 410 Horse-Power Engines and Attains a Speed of 125 Miles Per Hour.



At Left:—Prof. Albert Einstein Who Has Decided to Leave Berlin Because of the Attacks Made Upon Him by Berlin Scientists. His Theories Were Not Criticised—But His Personality and the Fact that He is a Jew, Einstein Has Been Offered Several Chairs in Both European and American Colleges.—(Copyright by Keystone.)

Below:—Milady Exercises in a New Fashion. After a Long and Dusty Drive, Anyone's Hair Would Need a Brushing, and This Physical Vitalizer, Which is Easily Attached to a Machine, Brushes the Hair to Perfection, and Even Massages the Hands and Face.—(Copyright by Keystone.)



Teaching Birds How to Sing Sweetly. Do You Know That Your Canary Bird Can Take Singing Lessons? They Have Special Music As Well As a Device Which Consists of Two Large Tanks Fitting Inside of Each Other Filled With Water, Which With Whistles of Various Notes Makes Music Such As Your Bird Sings Today.—© Kadel & Herbert.

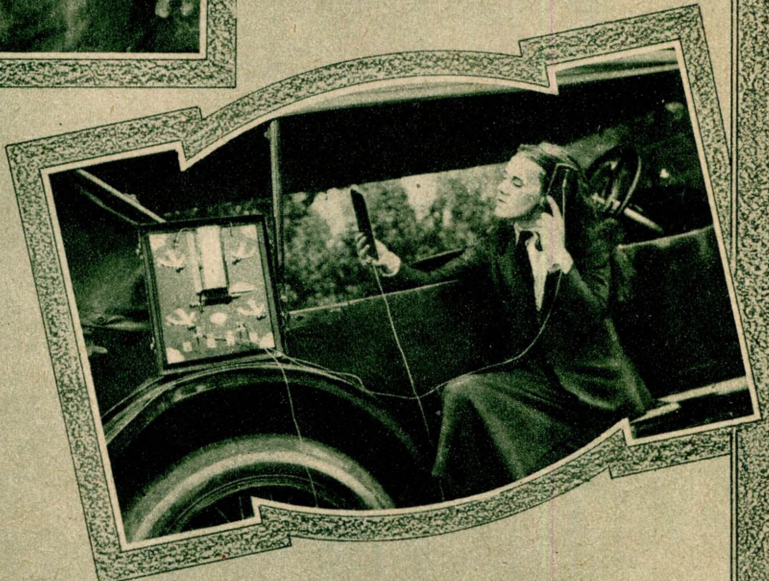

SCIENTIFIC XMAS TOYS

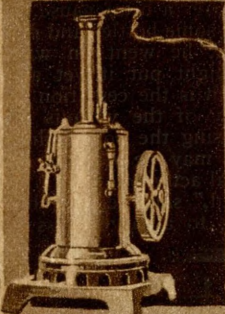

Toy Electric Steam Engine With Vertical Cylinder. The Boiler is Nickel Plated and Equipt With a Safety Valve, a Whistle, Gage Glass, Driving Pulley and Flywheel. It Will Drive Toys and Operate a Miniature Shop.

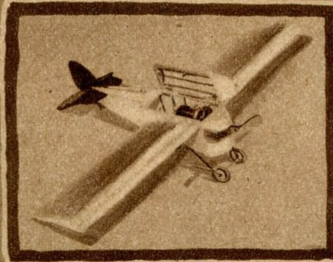

This Toy Airplane is Equipt With a Real Electric Motor and Diminutive Battery. It is Built Exactly Like a Flying Monoplane in Principle Except That Its Power is Electric.



A Pretty Nursery Gift is This Small Lamp Shade of Two Layers of Silk, Between Which is the Child's Own Silhouette, and That of the Pet Puppy.



By Pressing a Bulb Held in the Hand, These Small Pool Balls Are Shot at Each Other. The Table Has the Usual Pockets and Everything.



Here is a New Folding Table for the Child Who Likes to Draw. It is Fitted With a Pantograph and a Blackboard, so That the Child May Trace Any Small-sized Picture.



This Tallyho Has a Crank in the Front Which Winds Up the Motor and Makes it Run Along the Ground. But the Crank Also Does Something Else. It Winds a Phonograph Inside the Tallyho and Plays a Tune as it Goes Along the Floor.



A Small Flat Music Box Underneath the Chair Plays a Tune When It is Sat Upon. A Novelty Filled With Surprise for the Youngsters. It is Wound With a Key Under the Chair.



A "Vest Pocket Auto" Weighing Scarcely 200 Pounds and Costing About \$200 Was Introduced to New York Recently by no Less a Distinguished Personage Than the Comely Miss Shown. She Caused Quite a Sensation When She Hit Busy Fifth Avenue. The Car is Electrically Run and Makes 10 Miles Per Hour on One Charge.

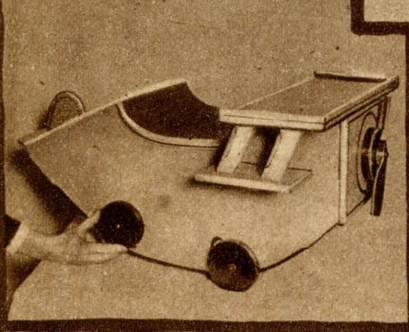

A Combination Version of the "Kiddie Car." For the Baby the Wheels Can Be Put Up in a Groove Out of the Way, So That the Car Will Rock. For the Older Child They May Be Let Down and the Car Operated by Foot Power.

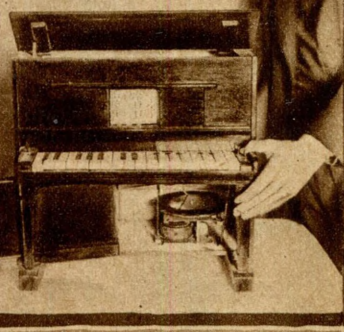

This Toy Piano Has a Player Roll Which Revolves in Realistic Fashion. Its Music, However, Comes From Beneath, Where a Phonograph is Concealed. The Toy Piano May Also Be Played By Itself.



A Prophet of Science

By JOHN DEQUER

"IN science must be found the solution for every problem which confronts the human race," remarked Dr. Pringle, as he watched the needle of a very sensitive galvanometer on his laboratory table with one slit-like blue eye, and with the other the ham string of a chloroformed dog with which he was experimenting. Then, as if suddenly changing the subject, he continued, "All life is accompanied by manifestations of electricity—just watch that needle."

Curious to know how he could connect the electric energy in the leg of an anesthetized dog with the problems that confront the human race I looked, at the same time urging him to explain himself more fully.

one would expect from their size, and his active brain interpreted what they saw with startling speed and accuracy. "You wonder how I can maintain that life is always accompanied by electrical phenomena, if muscles continue to liberate this energy after the animal is dead, or when they have been removed from the organism to which they belong?"

I admitted that he had read my thoughts aright, and ventured the opinion that the electric energy manifested by the muscles

energy into the kinetic energy of life," he explained. Then after a brief pause during which he arranged some bottles and pipettes on a nearby shelf, he went on with his explanation. "I might put it yet another way. Organic death is the cessation of the cooperative activity of the various organs and tissues composing the body, while the death of the cell may be defined as the cessation of its vital activity.

"This cat is dead," said he, "yet here in this jar"—pointing to a large glass bottle

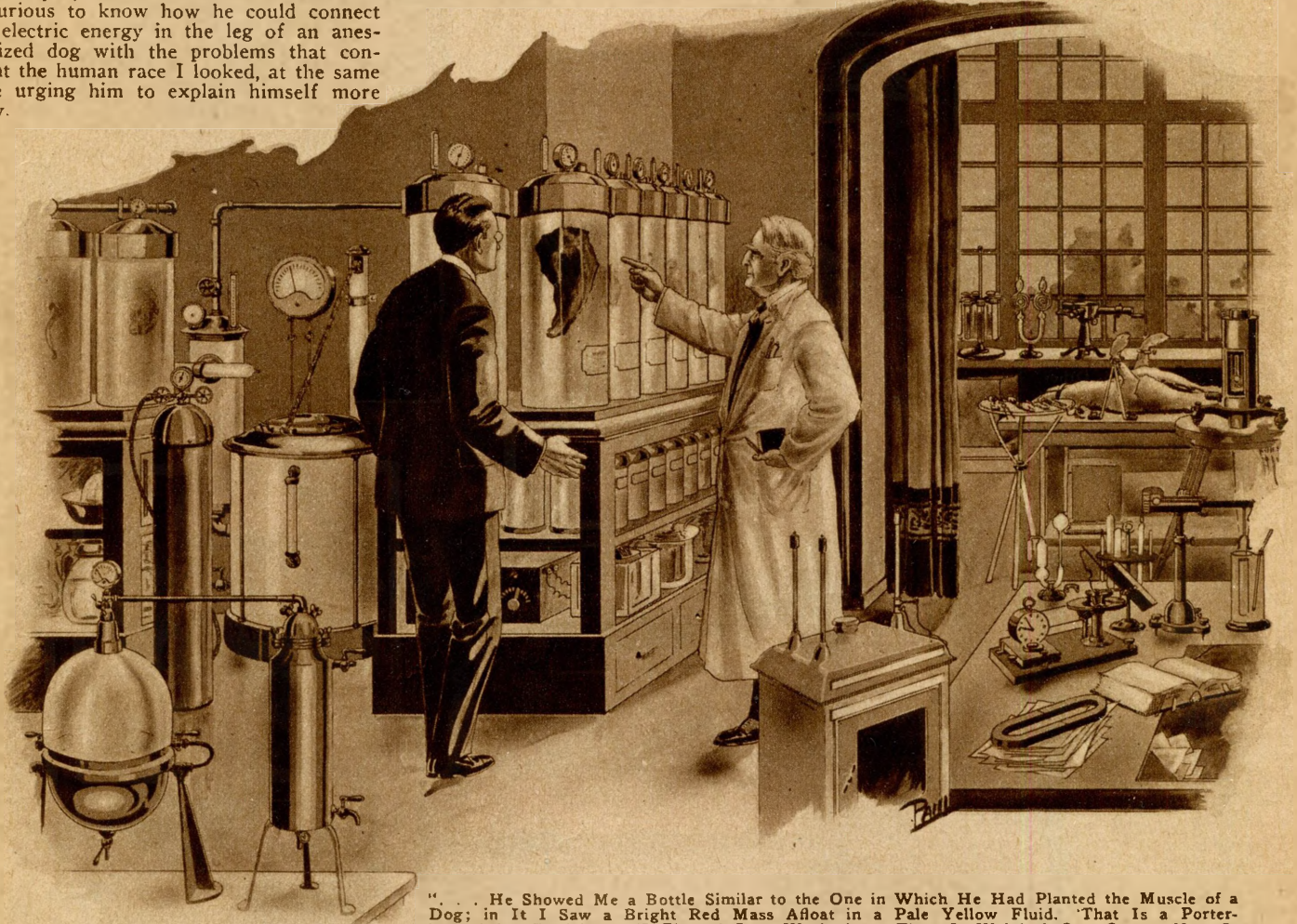

"... He Showed Me a Bottle Similar to the One in Which He Had Planted the Muscle of a Dog; in It I Saw a Bright Red Mass Afloat in a Pale Yellow Fluid. 'That Is a Porterhouse,' He Explained. 'I Planted It a Week Ago. Then It Weighed One Ounce, Now It Weighs Three and One-Half Pounds and Is Pure Meat; and What Is More Important to Me, It Grows Unassociated With a Highly Sensitive Organism. . . .'"

"Just watch these experiments," said he, "and see if they will not prove to you that there are no unrelated facts in the universe. The needle in the galvanometer, as you know, shows that this muscle is liberating electricity. I recognize that this in itself is a rather uninteresting, and I might say unimportant, detail of my research work. But so was the kite-flying experiment an apparently unimportant part of Franklin's life work; yet it was that kite-flying above everything else which gave him a place among the immortals."

As he spoke, he kept on testing the muscles of the comatose canine with his electrodes, and jotting down the variations of the needle in his note book. After a few minutes of this work, he said, "Now we will kill our dog and see if this energy ceases with death, altho I can tell you right now that it does not."

I know that my looks betrayed my surprise, and Dr. Pringle noticed it. Those narrow eyes of his noticed far more than

might be due to chemical action going on in the tissues regardless of their being dead or alive.

A smile lit up his thin lips as he arose from his stool at the laboratory table and walked over to an ice box at the other end of the room. From it he brought the carcass of a rat. It had been dead for some time as it was thoroughly stiff, and when he subjected its muscles to the same experiments he had tried on the muscles of the dog, no variation of the needle was visible. And when I asked him for his explanation, he told me that the death of an organism was one thing, while the death of its component cells was quite a different proposition.

"The death of an organism is due to a cessation of the functional activities of its component parts, while the death of the cells takes place with the chemical disintegration of the protoplasm to a point where it ceases to be an instrument for the transformation of electro-magnetic

protruding out of a little box on a nearby shelf, "are its lungs, in quite the opposite condition. They are nourished by a modified sea water and a few glandular extracts, as well as supplied with super-oxidized air from the tank. By means of a system of tubes, they are supplied with the products essential to their nutrition and drained of the waste of their metabolism, in a manner not unlike that by which they were supplied and drained in their original habitat. The result is they continue to live and grow, while the rest of the cat returns to the elements."

"But why do you keep this bottle in that little metal box?" I queried.

"I am trying to stimulate cell growth by means of the radio-activity of uranium ore," he elucidated. "It has been proven that the plants will turn away from the sunlight, if a minute quantity of radium be placed near them. They will also continue to grow at night in the presence of this wonderful

(Continued on page 914)

ELECTRIC HEALTH AIDS

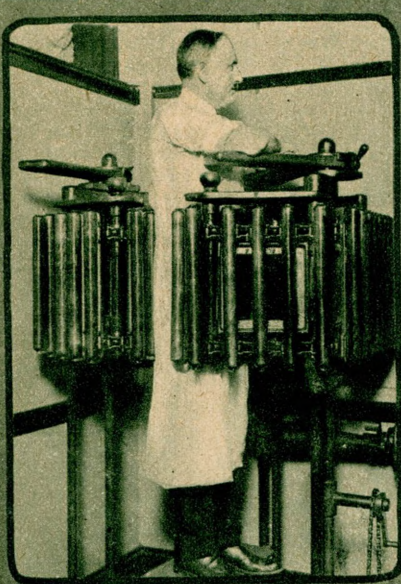

Hot and Cold Water Alternately and Electrically Sprayed on One are Rather Breath-Taking Sensations. Nevertheless Medical Science Thoroughly Approves of the Method as a Stimulant for the Recuperating Patient.

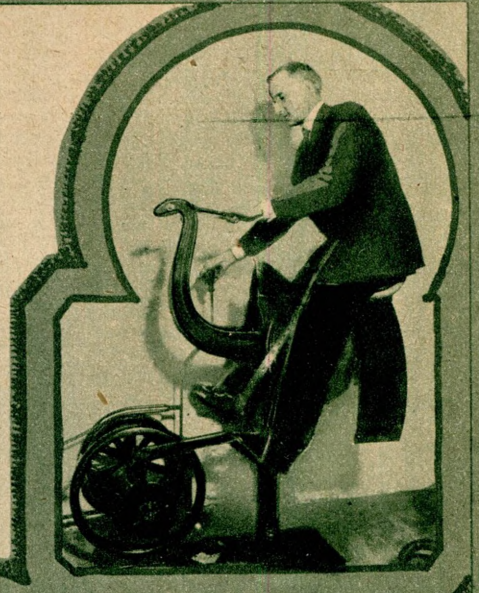

It is no Longer Only a Theory That Rolling Devices Remove Flesh. It is Now a Substantial Fact. Electricity Revolves These Elongated Rollers Which Flatten Out the Enlarged Abdomen as Mercilessly as the Street Steam Roller Repairs a Road.



The Electric Horse is Equipt With Gear Shift Levers, Battery, Switches, etc. It Gives the Rider all the Muscular Exercise He can Gain by Horseback Riding, and Nearly all of the Pleasure. Its Speed can be Regulated by the Rider to Suit His Desires.



To Quickly Dry a Convalescing Patient's Hair Place an Electric Toaster Behind an Electric Fan. The Heat From the Toaster is Drawn by the Fan Forward, So That it Quickly Finishes the Task of Hair Drying.



"The Inhalatorium" is the Official Name for This Little Closet of Enameled Steel. Menthol or Some Like Medicant is Placed in the Little Round Disc on the Wall. Steam is Electrically Regulated and Forced Into the Closet, and the Sore Throat and Bronchial Tubes are Quickly Soothed.



A Mechanical Osteopathic Machine Is This Weird-Looking Device Which Is Equipt With Eight Ball-like Revolving Parts. These Parts Grasp the Horns of the Spine, Giving an Electric Revolving Massage Stroke to Them.



"...For an Instant the Rat Seemed to Sit Motionless on the Desk Top; Then a Convulsive Shiver Shook Its Frame and It Seemed to Shake Imperceptibly. 'Dead,' Said Dr. Weeks, Glancing at Me Significantly. 'Heart Failure.' I Shivered. From a Pigeon-hole of the Desk, She Drew a Second Phial, This Time Filled With a Black Solution. 'The Antidote,' She Said Briefly...."

Life or Death

By CHARLES S. WOLFE

WITHOUT looking up or pausing in his incessant, illegible scribbling, the city editor heard my recital. When I had finished, he promptly gave his decision.

"Phone calls from unknown physicians are unusual enough in themselves to warrant investigation. This one goes a step farther, and actually promises a startling story. Run over and see him, at once. If it flivvers we're nothing out."

Accordingly I taxied forth to rick down this strange scent which had trickled into the nostrils of we "news hounds."

As the cab jolted its way across town, I speculated on the outcome of my errand. The whole thing was so different from routine assignments that I was tempted to expect—or at least hope for—something real big at the end of the trail.

Chance, pure and simple, had brought the thing into my hands. Some one had called the *Star's* office and asked for a reporter. Being about the only one of the clan at liberty at the time, the girl at the board had summoned me.

A voice on the other end of the wire had informed me that Doctor Weeks had a story for the press, and asked that a man be sent to the physician's office to handle it. The address was given readily on request, and before laying the matter before the editor I had taken the precaution to look up the doctor in both 'phone book and directory.

The address and name appearing there corresponded nicely to that given by our unknown caller. Our little conference followed, and I got under way.

Sitting there gazing out into the electrically lighted streets thru which we were fitting, I tried in vain to recall the name of Doctor Weeks and connect it with anything of moment that had previously been brought to my attention.

This proved fruitless. The names of possibly a dozen of the city's medical men who had been in the lime-light in various

connections occurred to me, but the name of Weeks was totally unfamiliar.

The address given was in a rather shabby section of the city. Not the slums, but a district inhabited largely by mill-hands and workers of a similar type. The possibility of a trap occurred to me, but after a minute's reflection I dismissed the thought. No one had anything to gain by luring me into a mix-up.

The stopping of the taxi aroused me from my reflections, and I glanced out to find that I was at the address given. Getting out, I paid the driver, and dismissed him. Gazing curiously at the building before me, I noted that it was one of a block of similar dwellings, differing only from its neighbors in that the window ledge bore the conventional brass plate of the practising professional.

Mounting the steps, I prest the button of the bell system, heard, muffled, the trilling of the gong, and waited, for it was well past regular office hours.

Presently there came the sound of footsteps, the rattle of shooting bolts, and the door opened to reveal a middle-aged man of rather short stature and commonplace features. He gazed at me expectantly, but did not speak.

"Dr. Weeks?" I queried.

"Have you an appointment?" queried the other, and I realized that I was dealing with the doctor's servant.

"Tell the doctor that Roberts, from the *Star*, is here as requested," I replied.

"Oh!" the tones told that I was expected. "Follow me, please."

Hat in hand, I trailed behind him thru the darkened hallway and into a dimly lighted outer office. The servant continued on toward large folding doors at one end of this room, and as I followed I took a swift inventory of my surroundings. The customary rather shabby waiting room of the average practitioner, nothing extraordinary or bizarre, was what I saw.

Clueless, I followed, awaiting develop-

ments. The man had opened the folding doors, and was standing to one side to allow me to pass.

"Mr. Roberts, from the *Star*, Doctor," he announced to the unseen occupant of the other room, and following hard on my announcement, I entered the inner office.

A beautiful young woman—she could not have been more than twenty-five—arose from a swinging desk chair and greeted me with an outstretched hand.

"Good evening, Mr. Roberts," the voice was indescribably pleasant. "It is very good of you to come."

As I stood there, dumbfounded, lower jaw sagging inanely, hat in hand, I surely must have looked exactly as I felt—like an ass. Nor was my recovery expedited in any way by the openly amused smile that played around the doctor's sensitive mouth.

"You did not expect to find 'Miss' Doctor Weeks, did you, Mr. Roberts?" she asked, mischievously. "Really, I enjoy giving a thrill to a hardened newspaper man. Sit down," she waived me to an empty chair, "and I will give you an idea of why I sent for you."

Recovering myself to some extent, I dropt into the indicated chair. "I must confess that I expected to find Doctor Weeks a man," I admitted, "but the fact that you are a woman encourages me to expect something a bit out of the ordinary as a reward for my trip. In our first surprise, we see a good beginning."

"I can promise you something very much out of the ordinary," she remarked, dryly, swinging to her desk and presenting me with what our illustrators call a three-quarter back view as she rummaged among a litter of papers before me.

I was thinking that as she sat thus she was not at all painful to look upon, when suddenly she wheeled to face me again, holding a cabinet size photo in her hand.

I took the proffered picture questioningly.

(Continued on page 935)

VON GUERICKE
WEIGHING AIR

VON GUERICKE'S
EXPERIMENT ON
PRESSURE OF ATMOSPHERE

VON GUERICKE'S
AIR THERMOMETER

VON GUERICKE'S
WATER BAROMETER

AIR PUMP

Torricelli

Otto von Guericke

Pascal

THE FIRST EXPERIMENTERS ON PRESSURE
OF ATMOSPHERE

VON GUERICKE'S
VACUUM GUN

EXPERIMENT ON
ATMOSPHERIC PRESSURE

TORRICELLI'S
BAROMETER

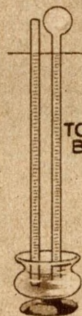

THE MAGDEBURG HEMISPHERES

Von Guericke, the Wizard of Atmospheric Pressure

By PROF. T. O'CONOR SLOANE, Ph. D., LL. D.

WHEN in the days of Galileo it was found that water would not rise by suction much more than thirty feet, the great philosopher was appealed to and could give no reason except that while Nature abhorred a vacuum, she only abhorred it to the extent of a column of water some thirty feet in height. This, of course, was no reason at all, and it is not the first time that the sage went wrong in his efforts to account for the ways of Nature.

It is often said that we live in an atmosphere just as the fish lives in an ocean of water, but there is an important difference; our specific gravity is much greater than that of the air, so we cannot float about in it as fish do in water. Nevertheless, the light, intangible air shows its material nature in storms and cyclones when the impact of its invisible molecules produces a destructive effect, and it is shown to possess weight from the fact that a vacuum involves a pressure of nearly fifteen pounds to the square inch, which pressure is due to nothing else but the weight of the air, just as truly as the pressure in the ocean's depths is due to the weight of the water.

Otto Von Guericke goes down in history as the first great investigator of atmospheric pressure, the first who proved by direct experiment that air possesses weight, and who showed what an astonishingly great pressure could be developed by the invisible and almost intangible aeriform fluid of the atmosphere. Realizing that air could be treated like water, he devised the air pump; he had to use considerable ingenuity, owing to the rudimentary knowledge of those days in devising ways of packing it. Having invented the air pump, he produced vacua in various vessels and developed an interesting line of experiments in connection therewith. The record of his experiments are preserved in an interesting old book published in Amsterdam in 1672. It was printed in the Latin language, and it is quite liberally illustrated; from its pages we reproduce some of the most striking experiments as described in it.

The Magdeburgh hemispheres are shown very clearly in the old book, and they are still in existence and preserved in the museum in their parent city.

As it was not easy to get a good ground joint in those days, leather packing was used to make a secure air-tight joint between the two air-tight hemispheres shown in the cut.

Putting them together, he applied his air pump and exhausted the air from them so that atmospheric pressure came into operation, and, on closing the cocks and removing the air pump, they were prest together with such force that two great teams of horses were unable to draw them apart. This striking experiment was carried out before the Emperor, Ferdinand the Third, in 1654 in Ratisbon when the Imperial Diet met there.

A curious fallacy is illustrated in his way of testing them, because if one of the hemispheres had been fastened to a fixed post, a single team of horses would have produced as great an effort as did the two teams; making one team pull against another is bad mechanics.

He now wanted to get some idea of the extent of atmospheric pressure and for this used a cylinder and piston. A good demonstration was given by having a whole crew

The Discovery of the Wonders of the Atmosphere

of men pull at it so as to draw the piston up or rather to attempt to do so, for though we allow even a partial vacuum, a piston of the size indicated would require a very large weight to be applied to draw it up.

Some January Articles

The Wonders of Frost. With photographs. By Jerome L. Lachenbruch.

James Watt and His Predecessors—The Invention of the Steam Engine. By Prof. T. O'Conor Sloane, Ph.D., LL.D.

How Germany Scientifically Utilizes Her Scanty Crops. By Dr. Alfred Gradenwitz.

The Divining Rod—Is It a Fake?

"How We Feel." By Joseph H. Kraus.

Man-Made Falls Higher Than Niagara Produce Electricity.

Recent Surprising Experiments in Ultra-High Pressure. Popularly illustrated.

Making Microphotographs. With illustrations. By Dr. E. Bade.

Is Electrocutation Humane? Answered by America's Greatest Nerve and Brain Specialist.

Fascinating Experiments in Chemistry. Part II. By O. Ivan Lee, B. Sc.

A New Scientific Story. By Charles S. Wolfe.

How to Charge Automobile Batteries at Home. By H. C. Petzwal.

In the book is shown a group of men pulling with all their might in an effort to raise the piston against atmospheric pressure. Then it was to be weighed and for this purpose a great scale beam and heavy weights took the place of the rope-pulling men so as to get a real figure in standard weights of what the pressure amounted to.

Again, a barrel filled with water cannot be pumped out under power without a vent to admit air, and we see the men laboring away in their efforts to draw the piston out against air pressure. He found that the barrels leaked air and abandoned this line of experiment.

Going back to the column of water, by using a sectional tube supported against a house he constructed a water barometer. The upper section was of larger diameter than the rest and in it a figure floating in the water and carrying an index was raised and lowered with the variations of atmospheric pressure and is shown carrying an

indicator to point to the markings on the glass tube indicating its position.

He weighed a globe exhausted of air and also full of air; the difference of weights gave absolute proof and measure of the weight of air.

Leaving the topic of atmospheric pressure, we also show some of his thermometers in which the expansions and contractions of air in a large globe operated a string passing over a pulley. A little figure attached to the string showed motion indicating the changes of temperature as the air expanded or contracted. This, however, also illustrates the changes in atmospheric pressure, because of course the air in the bulb will expand and contract with the rise and fall of the barometer even though the temperature remains constant.

It is about here that Von Guericke's work ceased and the Italian Torricelli put in a bit of reasoning on the ground that if a column of water over thirty feet high was supported by air, then mercury, fourteen times heavier than water, would also be supported, but only to a height one-fourteenth as great. These are all approximate figures.

Accordingly, he constructed a mercurial barometer, and some representations of his barometer are given here, two varieties being shown. They of course were simply closed tubes which were filled with mercury, the open end was next closed by the finger; the tube was then inverted in a cistern of mercury, the mercurial barometer resulting and carrying out a logical reasoning of the experiment.

There was yet another step to be made. If the barometric column was sustained by the pressure of air, it would fall with it on going up a mountain, when less and less air would rest upon the mercury in the cistern, and then the column of mercury would descend in the tube.

It was Pascal who applied this test, ascending a mountain called the "Puy de Dome" in the Auvergne regions of France. On carrying out the experiment in which his brother-in-law was also deeply interested, the mercury fell as the mountain was ascended and at last the culminating principles of atmospheric pressure and demonstration of its cause on the most logical basis was supplied.

Von Guericke was born in 1602 before either of the other two, and he survived them by a number of years; thus the three may be regarded as co-workers in this field rather than as successors.

Otto von Guericke, who was burgomaster of Magdeburg, and who is often alluded to under his official title with name omitted, understood the value of size in rendering demonstrations impressive. For, while the school boy's wet leather sucker with which he can pick up a flat stone or brick, and while the imbibing of a fluid thru a straw demonstrate atmospheric pressure perfectly, they lack in impressiveness.

In the older days much greater attention was given to this side of experimentation. So the old burgomaster did things on the large scale and his name goes down the ages because of the magnitude as well as completeness of his demonstrations.

The modern experimenter often attains his results with comparatively simple and small-sized apparatus. In Paris there is preserved the elaborate large-sized apparatus of the lamented Lavoisier. It is a great contrast to what a modern scientist would use.

Water Curtain Protects Firemen

By J. R. SCHMIDT

RECENTLY the Cincinnati Fire Department has tried out a novel scheme to protect the lives of firemen. By this means it now becomes possible for a man to walk right into the hottest fire with flames playing all around him, without in the least endangering his life. Our cover illustration perhaps shows the idea better than words. It is simply a curtain of water which sprays the fireproof uniform with a continuous stream of water, enshrouding the fireman entirely with it. The water being transparent, he can see far enough ahead providing the flames do not cut off the view. He can then do all sorts of rescue work, an example of which is shown in our cover illustration. Here the fireman is seen holding a child closely to his breast, while the protecting water curtain not only protects him but the child as well.

This fireman can stand right in the midst of flames and will not get burnt. He need not fear the glowing embers around his feet. He can walk right into the fiercest fire and it will dwindle away and go out around him.

As for the uniform, it is made of fireproofed canvas of two thicknesses, between which water flows constantly. The water enters by means of a perforated brass tube which encircles the neck between the two thicknesses of canvas and flows down between the layers thru the arms and legs, finding exit at the finger tips and around the soles of the feet.

Water flowing only between the two thicknesses of canvas would not offer complete



The Latest Thing in Firemen's Suits—It Sprays a Sheet of Water Down Between the Inner and Outer Coverings, as Well as Providing an Outer Water Curtain as Shown. This Water Curtain Protection is Supplied From the Main Fire Hose in the Manner Made Evident.

protection to the wearer, so, to keep him cool and comfortable while standing in the hottest fire, the brass perforated circular tubes encircle the helmet and give him a constant shower bath from the outside as well as within the folds of the uniform. This not only keeps him from becoming overheated but also acts to extinguish the fire around him.

which flows to the helmet is secured from a by-pass which is attached to the main water hose. This new invention has given such good results that it is sure to be adopted by most of the fire departments of the country. The life of a fireman has long been rendered extremely hazardous owing to the lack of effective heat insulating means such as this to protect his person.

Encased in this airtight water-bathed uniform, some provisions must be made to get fresh air to the fireman. He need not fear his air supply giving out as long as water continues flowing thru the hose he is holding. The air supply comes from the atmosphere surrounding him no matter how much smoke, flame or gas is contained in it. It is sucked into a patented collar which fits onto the hose just back of the nozzle. In the mechanism of the collar the contaminated air is washed and made pure and sent by the pressure of the water flowing thru the hose up into the helmet for the fireman to breathe. The foul air or gases find their exit thru vents in the helmet.

The same collar which washes and purifies the air for the fireman to breathe also has the water hose connection which supplies the water curtain. With this uniform a fireman stood in the flames of a burning wood fire for ten minutes without becoming uncomfortable. Altho the fire was kept burning fiercely all around him he came out with a grin on his face and not even perspiring!

From our cover illustration it will also be noted that the water

Acid-Resisting Alloy

ALVAH W. CLEMENT has invented and patented an improvement in acid-resisting alloys. The purpose of this invention is to provide an alloy of metals which is highly resistant to acids, more particularly sulfuric acid, even tho that acid be in a hot diluted condition.

Such an alloy is useful to form containers, pumps, pipes and cocks, and other articles by which acid may be handled the same as other fluids.

The principal ingredients of the alloy which is herein proposed are iron, chromium and carbon, the latter element being present as carbids of iron and chromium.

Small quantities of silicon may be used in fusing the mixture to render the alloy more fluid, in order that it may be more easily handled. The quantity of silicon thus used is small, however, preferably

less than 1 per cent, and usually varying from seven-tenths to nine-tenths of 1 per cent.

In order to counteract any tendency for the silicon to throw down the carbon as graphitic carbon, a small quantity of manganese may be used, approximately three-tenths of 1 per cent.

It will be apparent that the quantity of silicon and manganese present in the alloy is quite small, and so far as the ultimate properties of the alloy in its acid resistance are concerned, has very little, if any effect.

An alloy of pure iron and chromium would not be resistant to the various commercial conditions under which sulfuric acid is handled, but an alloy of chromium, iron and carbon, where the carbon exists in the alloy as carbids of chromium and iron

in the proportion of substantially 60 per cent chromium, substantially 39 7/10 to 39 2/10 per cent of iron, and substantially three-tenths to eight-tenths per cent of carbon is to all intents and purposes resistant to all forms of sulfuric or similar acids.

One-quarter to one-half of 1 per cent of silicon may be added at fusion and just before pouring, to impart fluidity to the alloy.

Furthermore, such an alloy is machinable. Therefore it is suitable for acid-resisting pipes, cocks, and similar devices.

It may be desirable to add to the alloy a small amount of molybdenum, cobalt or vanadium, these various substances mentioned having the property of increasing the malleability and ductility of the alloy and thus rendering it easier to machine.



Photo Above Shows the Inventor, M. Eugene Lauste, Who Has Devised the Latest Thing in Phonograph Records—a Record on Which the Voice is Recorded by a Scratchless and Weightless Ray of Light, Giving More Perfect Musical Reproduction.

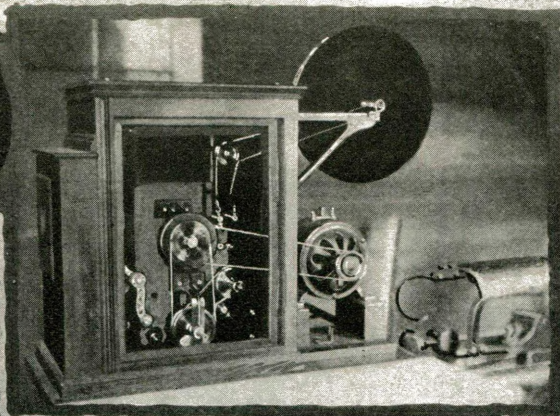

POWERFUL TUNGSTEN LAMP

LENSES

LENSE FOCUSING DEVICE

MICROPHONE

BATTERY

PRESENT LIMIT
5,000 VIBRATIONS
PER SECOND

LAUSTE LIMIT
35,000 VIBRATIONS
PER SECOND



OLD NEEDLE RECORD



LAUSTE LIGHT RECORD OF VOICE

Diagram Above Shows How the Greater Range of Frequency and Fidelity in Voice Recording are Attainable With the New Lauste Light Ray Method, Compared to the Usual One Employing the Steel or Other Needle.

MAGNETICALLY OPERATED LIGHT SHUTTER

RECORD

WORM NUT

WORM SCREW

MOVING LIGHT RECORDER



In This New Scheme for Recording the Voice on a Disc or Other Type of Phonograph Record—Which Mr. Lauste Has Given Us—a Concentrated Ray of Light is Caused to Record the Fluctuations of the Voice on the Revolving Record. The Carriage Carrying the Light, and the Voice Operated Shutter is Traversed Across the Record by Means of a Worm Screw as Shown. The Record, After Suitable Treatment, can be Reproduced by a Regular Metallic Needle, But Yields a Much More Perfect Vocal or Instrumental Reproduction Than Anything Heretofore Accomplish.

The Light Ray Phonograph

By ERIC A. DIME

ALL sounds, speech or music, are recorded on the discs of the present day phonograph by means of a metal needle. This needle has a rate of about 5,000 vibrations per second, as it cuts the grooves on the disc. This method makes a reproduction of sound, but it is impossible to record all the overtones of music. Hence perfect music cannot be recorded by means of the metal needle.

How to overcome the drawbacks of the present method of recording sound on phonograph records has been solved apparently by a scientist and inventor who is widely known for several important inventions. We have reference to Eugene Lauste, a Frenchman, who is a pioneer in cinematography and the inventor of the *Laustophone*, the latter being an instrument for taking and reproducing talking motion pictures. Mr. Lauste was associated with Thomas A. Edison from 1886 to 1893, during which time he did some valuable laboratory work for the "Wizard of Menlo Park."

A few weeks ago I visited Mr. Lauste in his laboratory in Bloomfield, N. J., in order to secure some information about his latest invention which may revolutionize the talking machine industry. He was at work on what he calls the *Electro-Phonograph*, which will employ a radically new method of recording sound on phonograph discs. The machine is not yet finished but the work done so far demonstrates the practicability of Mr. Lauste's theory and how he will be able to produce a disc which will contain every inflection of the human voice

How the Newest Phonograph Record Is Made with a "Light Ray" Stylus

—something so far unheard of in the field of the phonograph.

Instead of the ordinary horn into which a person talks or sings when a record is made on the common phonograph, Mr. Lauste employs a *microphone*, similar to the instrument on your telephone, into which you talk. The horn distorts sound as it enters the machine, to which all familiar with acoustics will testify, whereas the microphone, which is one specially made by the inventor, will accurately convey the natural tones to the instrument for the recording process. In a room a person can stand at a distance of forty feet from the microphone and talk or sing—and still the sound will be received perfectly in the microphone for the recording process.

From the microphone the sound is electrically transmitted into a device that Mr. Lauste calls the *pantograph*, which intensifies the sound and transmutes the mechanical vibrations into electric light ray vibrations. The pantograph takes the place of the diafram to which the needle is attached in the ordinary talking machine. The new instrument has a device for generating a powerful electric light ray, which is here used instead of the well-known needle for cutting or rather forming the grooves on

the disc when a record is made. The guide for the light ray has its point within 1-16 of an inch of the record. This is done so as to narrow down the light beam to as fine a point as possible. In fact it is possible to obtain a finer point with an electric light ray than with the metal point.

The inventor told me that the light beam, thus used for recording sound on the specially prepared disc, produces about 25,000 vibrations per second, and this makes it possible to record clearly all the overtones in music on the coated wax disc. That the metal needle is capable of only about 5,000 vibrations per second, is due to the interference of friction and inertia in the needle and the diafram. The finer tones have not the power to speed up the needle to the necessary number of vibrations essential to the recording of all undertones and overtones. On the other hand there is practically no resistance to the light beam which is caused to vibrate at a terrific rate by the electro-magnets mounted in the pantograph of the instrument. The light beam cuts its grooves laterally in the disc.

After the first record is made, then the master record and duplicate records are run off in the same manner as are the records for the different makes of phonographs in use today. There is no special talking machine required for using the records made by the Lauste *Electro-Phonograph*. The new type of discs will fit any phonograph that employs a steel or other pointed needle for lateral grooves. And as the steel needle follows the grooves made by

(Continued on page 924)

What Are Dreams?

By WILLIAM M. BUTTERFIELD

Is the Dream Merely Subconsciousness?

DREAMS, "children of an idle brain, begot or nothing but vain fantasy," of what earthly substance are your fleeting phantoms compounded? The ape-man, sleeping in the crotch of a mezoic pepper-tree, dreamed and wondered just as his

awake, in words,—but when asleep, in visions. These dream visions are for the most part vivid and seemingly realistic, creating ideas in the early days more or less fantastic and untenable in modern thought, yet of such a character as to form the first conception or belief of the

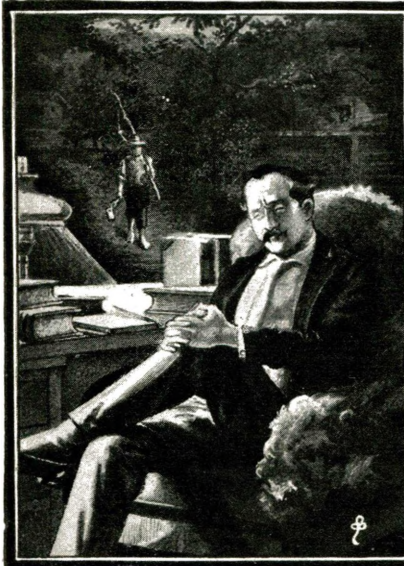

A Busy Mind Constantly Engaged Very Often Desires to be Rested. In a Few Minutes It Will Take the Person Back to the Delightful Scenes of Childhood. Such Dreams are Stimulative and Very Often Occur in Little Catnaps, Day Dreams and Reflections, of a Pleasant Summer or Childhood Days.

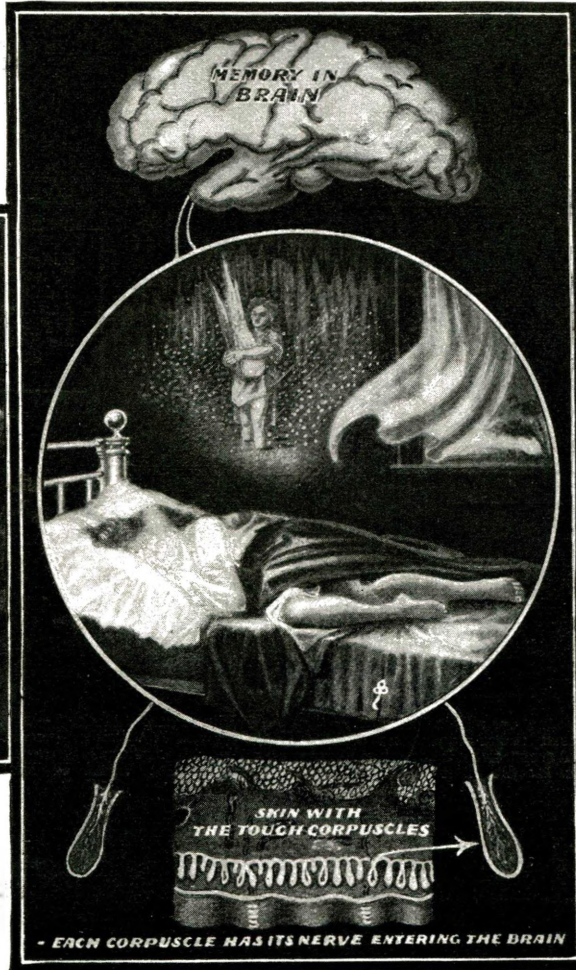

Above is Shown a Dream Induced by the Exposure of Parts of the Body to a Draught of Cold Air. The Sense of Touch Seeks to Arouse the Mind to Protect the Body and Forms a Mental Picture of the Sleeper's Knowledge of Cold, i.e., Ice, Snow, Icicles and Snowdrifts, All Unpleasant, in This Way Attempting to Communicate the Danger Which the Sleeping Body is in.



Nightmares Such as These Often Repeated are Generally Indications of a Diseased Body or Mind. Some Nightmares May be Caused by Food Which Did Not "Agree" with the Person, But a Continual Variation of Uncanny Nightmares Should Invite the Owner to Request the Services of a Reputable Physician.

progeny, the highly cultured man of today, rising from his satinwood bed, has his periods of speculative inquiry.

Millions of years of mental experience and development have not removed the veil of mystery, and the human race as a whole are as ignorant of the true cause or philosophy of dreams as was the hairy savage, shivering with fear and apprehension in his tree-top. Indeed, it is probable that many shiver more now, from fear and the effect of dreams as a result of this mental development, than the ape-man ever did.

Dreams of all mental sensations—elusive, fantastic or mystic as they may appear, have had more to do with the development of the mind than any other group of inflexes. No other operation of

the mind has the power to arouse the same degree of pleasure, distress or terror—hence dreams have from the earliest days of human history exercised a powerful influence over the thoughts and acts of men.

Our waking thoughts are express in unspoken or mental words, while our sleeping thoughts, or dreams, are express only in picture form; thus we think while

soul. One idea express is that the soul is a separate, non-physical part of the body; another, that the soul is the mind.

Robert Gray in his "Theory of Dreams" (1808) started what may be called our modern dream investigations, which have been followed by many theories such as: duplex-brain theory, vaso-motor theory, thyroid and hypophysis theory, chemical, histological and biological theories, and finally, the present 1919 psycho-biological theory. The earlier ideas, of course, are supposed to be wiped out and thrown into the discard by the presentation of this psycho-biological proposition. It is needless to say that this theory is already objected to and is threatened with extermination by a newer idea.

(Continued on page 898)

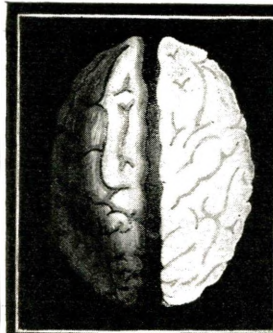

Duplex-Brain Theory Says One-half of the Brain is Fully Developed. We Use This Half When Awake; the Other Half is Only Partly Developed. We Use the Less Developed Half During Sleep.

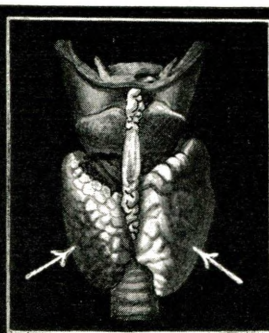

Thyroid-Gland Theory Says Sleep is Caused by a Change in Secretion in the Thyroid Gland. This Gland is Below the "Adam's Apple" and is the One Enlarged in Goitre.

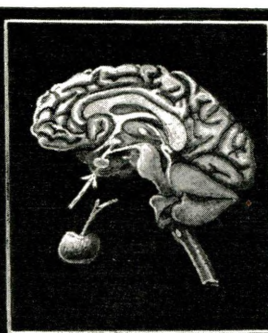

Hypophysis Theory Says that the Hypophysis is Responsible for Sleep. It is a Gland of Two Parts Which is Located Just Below the Optic Nerves Within the Cranial Cavity.



The Biologic Theory Says Sleep and Dreams are Instincts Developed from the Primitive Rest State of Animals, Which Man Inherited and Has Complicated.



Psycho-Biological Theory Accepts the Biologic Theory for the Body, but Says the Mind is the Soul and That it is Conscious When Dreaming or in Sleep—Therefore Superior to the Body.

Lamp Facts for the Householder

By JOHN W. HAMMOND

of the General Electric Co.

DELICATE, adaptable, indispensable—such is the incandescent lamp as developed and used today. Its history is the history of the method of producing light by artificial means. In modern lamps, tungsten is almost exclusively the light source.

That part, the slender, hair-like wire within the bulb of the incandescent lamp, which is heated by the passage of the electric current, producing the illumination that radiates from the bulb, is termed the filament.

The smallest tungsten wires drawn measure only four ten-thousandths of an inch—

The tungsten construction in Mazda "B" and Mazda "C" lamps is different in each case. In the Mazda "B" lamps, known also as the vacuum type, straight tungsten wire is draped over the supports, in order to get a sufficient length of wire inside the bulb for the voltages met with. Expensive and complicated machines produce in these bulbs the highest degree of vacuum in commercial use.

In the Mazda "C," or gas-filled, type of lamp (sometimes referred to as nitrogen-filled), coiled tungsten filaments are used, for three purposes: to increase the effective diameter of the filament, to reduce the

them according to the size of the socket, which fits the base; the next subdivision classifies them on the basis of the watts consumed; and, finally, they are designated in accordance with the kind of bulbs used.

Under the first subgrouping, lamps are termed large or miniature. Large lamps, used for residence, store, office, factory and street lighting, have bases fitting three types of sockets: the medium screw, the mogul screw or the medium bayonet socket. The bases of miniature lamps, which are used chiefly for flashlights, auto lamps and decorative purposes, will also fit three kinds of sockets: the miniature screw, the can-

The Average Householder Frequently Makes a Mistake in Using Either Lamps of Too Great a Candle Power, or Else Cheats Himself by a Poor Distribution of His Lights. The Accompanying Article Attempts to Set Him Right Both as to Efficiency and Economy in Household Lighting.

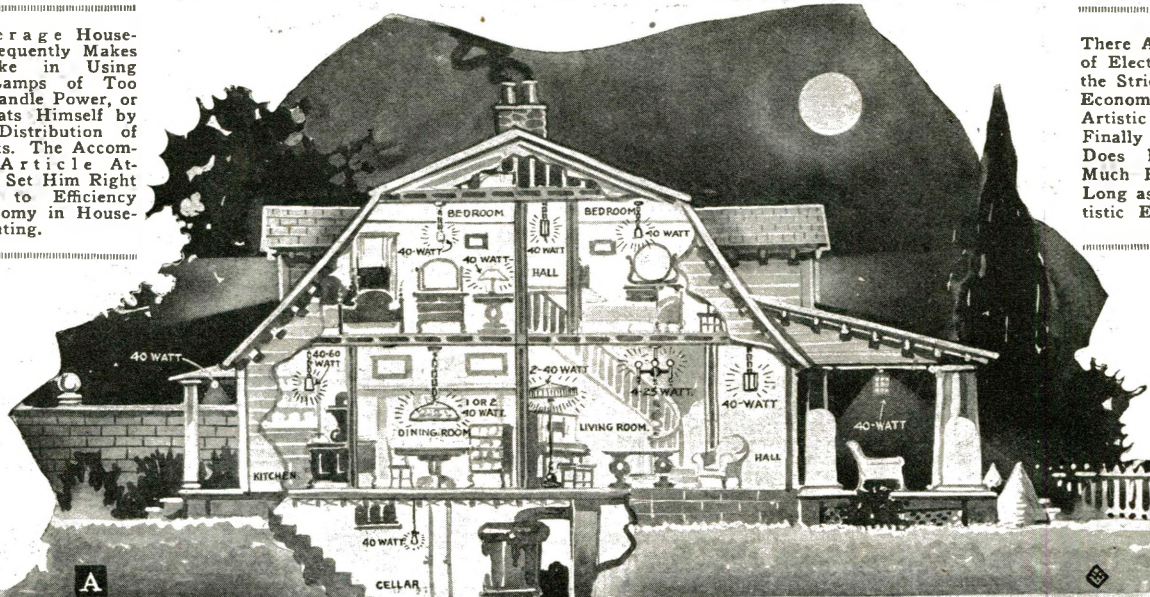

There Are Three Classes of Electric Light Users: the Strict Economist, the Economical Lover of Artistic Lighting, and Finally the One Who Does Not Care How Much His Bill Is, as Long as He Obtains Artistic Effects.

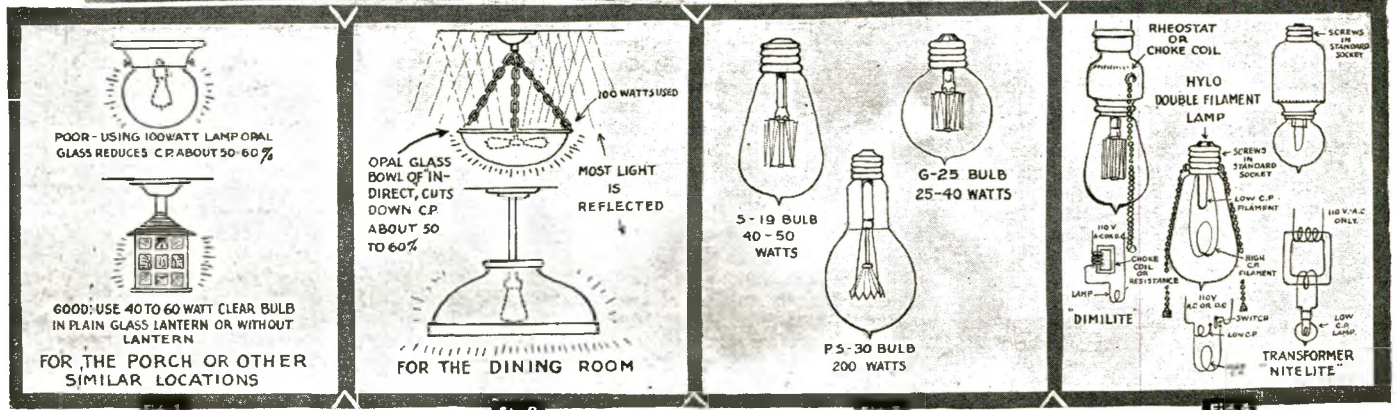

Some Practical Hints for Those Desiring the Highest Economy in Electric Lighting Are Shown in the Lower Illustrations, Figs. 1 to 4. Fig. 2 Shows How Approximately One-half the Candle Power Produced Is Utilized in Reflecting the Light Upward to the Ceiling and Back Again. Fig. 3 Shows the Three Principal Types of Incandescent Lamps, While Fig. 4 Shows the Three Leading Types of Nite-lights, Which Also Have Many Other Uses, of Course.

approximately one-sixth the diameter of the average human hair. These practically invisible threads of wire are used in small lamps for illuminated signs.

In general, the incandescent lamps familiar to this twentieth century world are divided into two broad groups—those in which the filament operates in a vacuum, as the Mazda "B" lamp of certain manufacturers, and those in which the filament operates in an atmosphere of gas, as the Mazda "C" lamp. These two classes are subdivided several times into other classifications.

losses, and to get sufficient length of wire inside the bulb for the voltages met with. Mazda "C" lamps are also carefully exhausted to produce a vacuum. After that, the bulb is filled with a gas (nitrogen, argon, etc.), which is high in density, low in heat conductivity and inert to tungsten and other parts of the lamp. This is done in order to make the lamp more efficient.

CLASSIFICATION OF LAMPS

As already stated, these two broad groups of incandescent lamps are subdivided several times. The first subdivision groups

delabra screw or the candelabra bayonet socket.

In the second subdivision, lamps are known as 10 watt, 20 watt, 50 watt, or whatever the case may be, the number designating the approximate watts consumed by the lamp when operated at its correct voltage. A few types of lamps are designated by candle-power, chiefly lamps used in street lighting and automobile lighting. This variation is due to trade conditions.

The familiar varieties of lamps in the third subgrouping, in which the kind of

(Continued on page 906)

The Submachine Gun

By ERIC A. DIME



Soldier Holding New Sub-machine Gun, Which Weighs but 7 Pounds and Has a Range of One Mile. It is capable of Firing 1500 Shots Per Minute.

sight. It is riddled with bullets and all tires are flat from scores of punctures. In the body of the car are huddled the limp forms of the crooks, whose bodies are perforated by leaden pellets. The money is saved.

This turn of affairs will be due to a

**Seven Pound Gun—Range
1 Mile—1500 Shots
per Minute**

Gun is a mechanism called the *Wedge* and this is the basis of a new principle in automatic gun design. By the use of this wedge the breech is automatically locked and released. This single part, weighing only a few ounces, replaces numerous heavy complicated pieces



The Illustration Above Shows Closeup View of Submachine Gun With Pistol Type of Magazine at Left, and Circular Drum Magazine Holding 100 Cartridges, at the Right.

Showing the Few Parts Constituting the "Sub-machine" Gun—the Simplest Machine Gun Ever Devised.



SOME day a couple of yeggs, who make their specialty of robbing banks and getting away with the swag, while engaged in one of their precarious pursuits, are going to meet the greatest surprise of their lives. In nearly all recent holdups they have been able to elude their pursuers. After the robbers grabbed several thousand dollars of the bank's money, they hopped into a waiting automobile and sped away. Perhaps they were chased by a police officer who exchanged fire with the thieves. The officer fired every shot from his regulation pistol without hitting the crooks, because he was far behind them and it was hard to aim straight. At last the yeggs made good their escape.

But this performance will not be repeated in its entirety on the day in question—the day of the big surprise. As usual, the yeggs will venture forth to increase their wealth by looting the safe of some bank that may look easy. There will be another order of "Hands up!" While frightened tellers and other people in the bank stand with their hands raised heavenward, currency and gold will be scooped into sacks carried by the thieves. Then for the get-away. Once more the crooks will slip into an automobile, with its engine purring, near the curb. Now they think they are safe, but they are reckoning without the host. Soon an officer of the law is on the trail. He sits in a motor car and levels what looks like a large pistol at the fleeting bandits. They see him and open fire. A few barks from their guns—then silence. The officer's weapon has spoken. From its barrel a deadly stream of bullets has poured at the rate of 1,500 shots per minute at the car ahead.

When the smoke of battle has cleared away, the bandits' machine presents a gruesome

new type of gun which the officer carried. It is called the *Sub-machine Gun*, a machine gun in the form of a large pistol not weighing more than seven pounds. The new gun is the invention of General John Thompson, Director of Arsenals and chief of small arms production during the World War. The New York Police Department thinks so much of the Submachine Gun that it has officially adopted the weapon, a number of which will be turned over to the Riot Squad for use in riots and in chasing thieves and other lawbreakers in automobiles.

The Submachine Gun has only eleven parts. Any one can take this new weapon apart and assemble it in less than a minute and the operation can be performed without the use of a single tool. The gun is made for calibers .22, .32, .38 and .45. The weight of the gun, depending on the caliber, ranges from three to seven pounds. The length of the weapon over all is from sixteen to twenty-two inches, also depending on the caliber. It has a range of a mile at which distance it will kill a man. The firing mechanism is of such construction that single shots can be fired or else a stream of bullets, like those from a machine gun in action, can be poured from the muzzle of the Submachine Gun at the rate of 1,500 per minute, as before stated. The ammunition may comprise ball or buck shot. Two types of magazines can be used on the gun. One is of the straight type used on automatic pistols, altho larger than the latter, while the other is of the disc type, which holds from 50 to 100 cartridges. A spring in the magazine feeds the cartridges into the breech.

A striking feature of the Submachine

weighing several pounds, common to other types of automatic guns, and the result is an accurate, positive, automatic action.

A stock may be attached to the Submachine Gun so as to convert it into a semi-automatic shoulder rifle firing single aimed shots as fast as the trigger can be pulled. Firing in this manner one hundred hits per minute up to 500 yards is a possibility and this is a hitting speed unapproached by any other shoulder arm in the world.

A report of the United States Marine Corps, Quantico, Virginia, date of August 24, 1920, says: "The very simple, positive and extremely rapid action of this gun was by far the most striking feature from a military standpoint. Approximately 2,000 rounds were fired during the test without a stoppage. There were no broken parts nor any repairs made to the gun while under the observation of the board."

During an interview I had recently with General Thompson, he said that if the Germans had been equipped with Submachine Guns during the closing days of the war, when the German man power could not compare in numbers with the forces of the Allies, the Germans might have got the best of the troops opposing them. Undoubtedly future wars will see all soldiers of the infantry equipt with light rapid machine guns held to the shoulder.

Auto Propels Armored Landing Boat

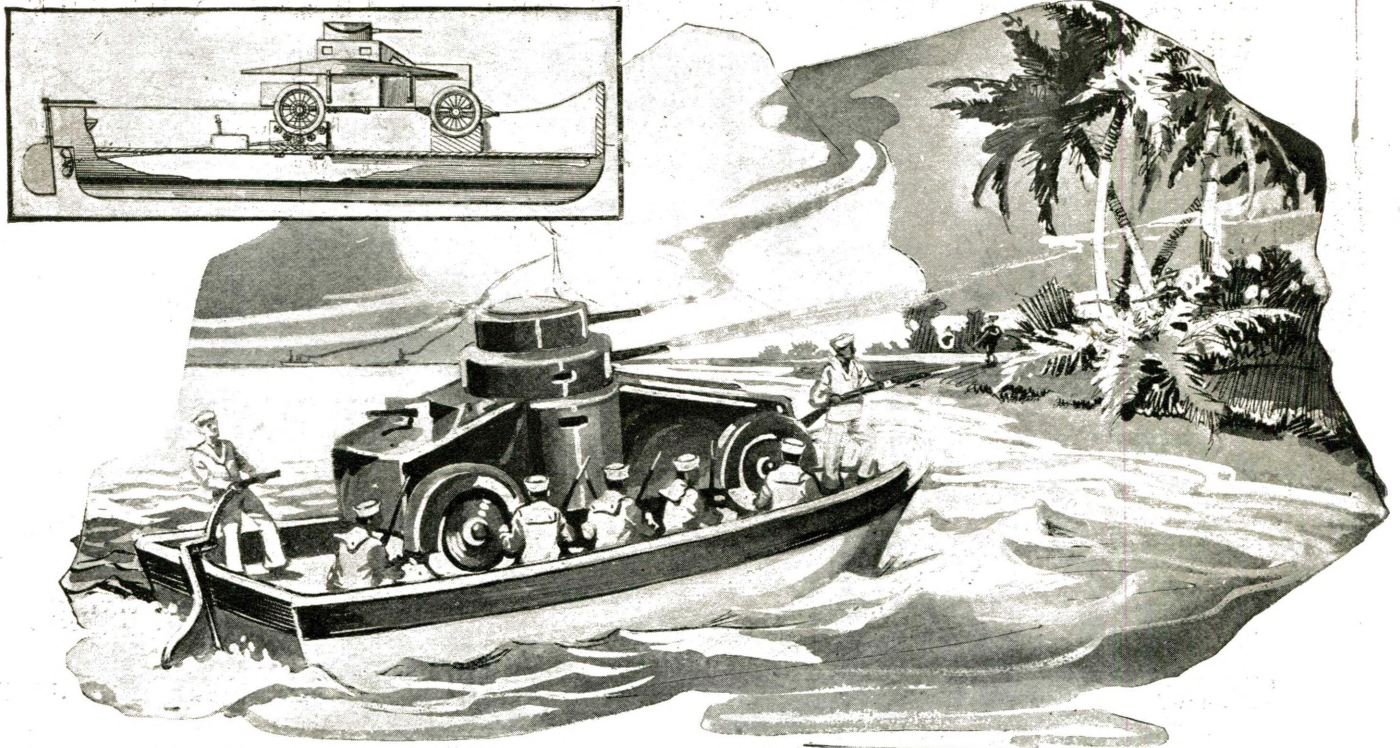

A Recently Patented Idea Which Will Find Extensive Adaptation in Future Warfare Maneuvers, Especially in Landing Troops or Marines As Here Shown. The Armored Motor-Car Is Caused to Propel the Landing Boat By Placing the Hind Wheels On a Series of Friction Rollers, Suitably Geared to the Propeller Shaft in the Manner Indicated in the Diagram at the Top of the Illustration. The Guns of the Armored Motor-Car Can Be Used While the Boat Is Moving, When Desired. The Front Wheels of the Motor-Car Rest in Grooved Chocking Blocks.

THIS interesting and, withal, practical invention relates to improvements especially designed for use as an equipment for transporting troops from vessels to the shore and at the same time to provide a motor vehicle of the armored type construction which may be used while on the landing boat as a means of offense, and which can, thru its own driving mechanism by suitable connections, transmit power to the propeller of the boat, and when the shore is reached can be landed and used in the ordinary way as an armored motor car.

The invention, which has been patented by Waldo A. Ross of Washington, D. C.,

contemplates the provision of a suitable boat having the usual propeller and gearing, which may or may not be operated by its own gasoline engine, and in connection therewith he provides an armored motor vehicle for the purposes above referred to which may be so supported on the boat so that the driving mechanism of the automobile may operate the propeller; and which is so arranged that when landed from the boat it may be used for scouting purposes or for the ordinary warlike purposes of such a vehicle.

Journalled in the housings and on each side of the rollers are idle rollers arranged

in an arc of a circle to correspond with the periphery of the tire of the vehicle, and upon which the wheels roll and which prevent the forward or rearward movement of the vehicle. The rollers, as shown, are below the upper edge of the housing so that the latter forms a guide for the wheels to prevent the sidewise movement thereof. The flooring of the boat forward of the housing is provided with blocks having convexed upper faces, in which rest the forward wheels of the motor car, and whereby the vehicle is supported in a level position.

Exploding Steel

By E. W. DAVIDSON

Who ever heard of a chunk of steel exploding? None of the metallurgists in the research laboratory of the General Electric Company ever had until one May day this year. On that day Herman Winkler, an employee busy hardening three slugs of ordinary Sanderson carbon steel to be used as plungers in making genelite, a new self-lubricating bearing metal, drew a slug out of the electric furnace at about 750 degrees Centigrade, quenched it in a tank and then took it in his left hand. With a rasp in his right hand he was about to test the slug's hardness when someone distracted his attention. In that moment the end of his rasp tapt the flat end of the slug.

"It flew to pieces with a crack like a pistol shot," said Mr. Winkler. "One chunk went by my ear, another went straight up and the remaining two dropt into the sink. It was peculiar. My hand was merely bruised a little bit."

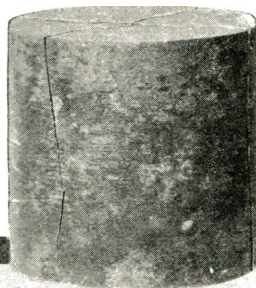

This Cylindrical Piece of Steel Burst at an Unexpected Moment and Nearly Killed a Tool-maker in the Great General Electric Works, Who Was Totally Unprepared for any Such Action as Here Occurred. The Photo Shows the Four Almost Equal Segments Into Which the Steel Cylinder Cracked, This Effect Being Attributed by Experts, to the Fact That Severe Internal Strains Were Set Up When the Steel Was Suddenly Cooled, and That This Resulted in the Sudden Bursting of the Solid Steel Piece.

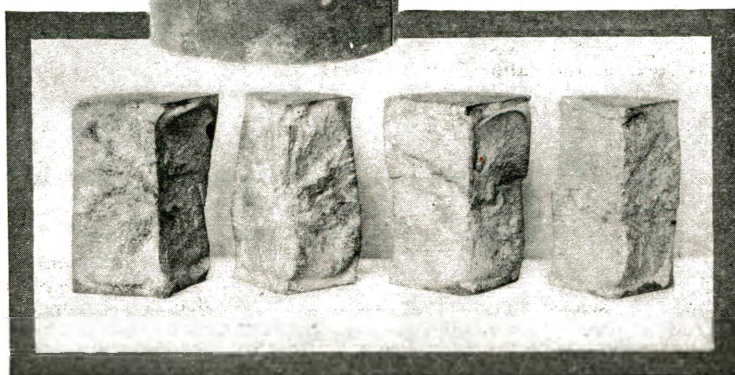

The only explanation advanced for the phenomenon is that the slug, which was about four and a half inches long and four in diameter, cooled a degree too quickly on the outside and the heat expanded core exerted a surface tension so unusual, that the slightest touch at that exact moment produced the violent fracture. The other two slugs from the same bar that day got what appeared to be exactly the same treatment, as have thousands of other steel slugs in times past, and not one ever responded as this one did. The photographs show there was no flaw in the metal, but the lines of core strain are obvious.

This phenomenon is indeed quite a remarkable one, and it is miraculous that the tool maker who had tempered the steel, just before it had exploded with great power, was not killed.

Safety Cowl for Airplane

A NEW safety cowl has been designed to lessen or eliminate injury to the pilot's face in the event of a crash. In practically every wreck that occurs, the pilot's head is thrown forward due to sudden stoppage of plane, and with the conventional construction of cowl or deck in front of him, even with the padding around edge of same, injuries to the face result of a more or less serious nature, such as broken nose, jaws, etc. In fact, in the minor crashes, the pilot and passenger often escape without any other injuries than these.

Some planes are constructed with a cowl entirely cut away in front of the pilot so that there is no obstruction between him and the instrument board. This not only results in poor streamlining of fuselage but the air currents blow into the cockpit. The

with even more serious results than by hitting the present cowl. In the accompanying illustration is shown the new device as fitted to the Curtiss Training plane. The original line of cowl is cut away in a U-shaped opening in front of the pilot's head and the space is fitted with a flexible elastic and leather material marked "C" in the drawing. The padding around the original cowl edge is retained and also fitted with an elastic about the size used for shock absorbers, and with a small

leather covering the arrangement will absorb a tremendous blow without any injury whatever to the pilot's face.

The celluloid windshield shown has its edge protected by a leather padding.

All the planes used at one of the Texas flying fields were equip with the device

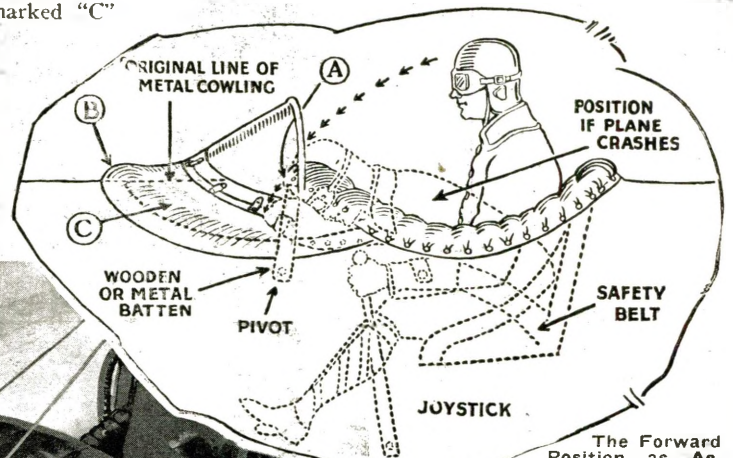

The Forward Position as Assumed by the Aviator in Case of "Collision" or "Crash," is Clearly Shown Above, —the Cowl Being Made Flexible.

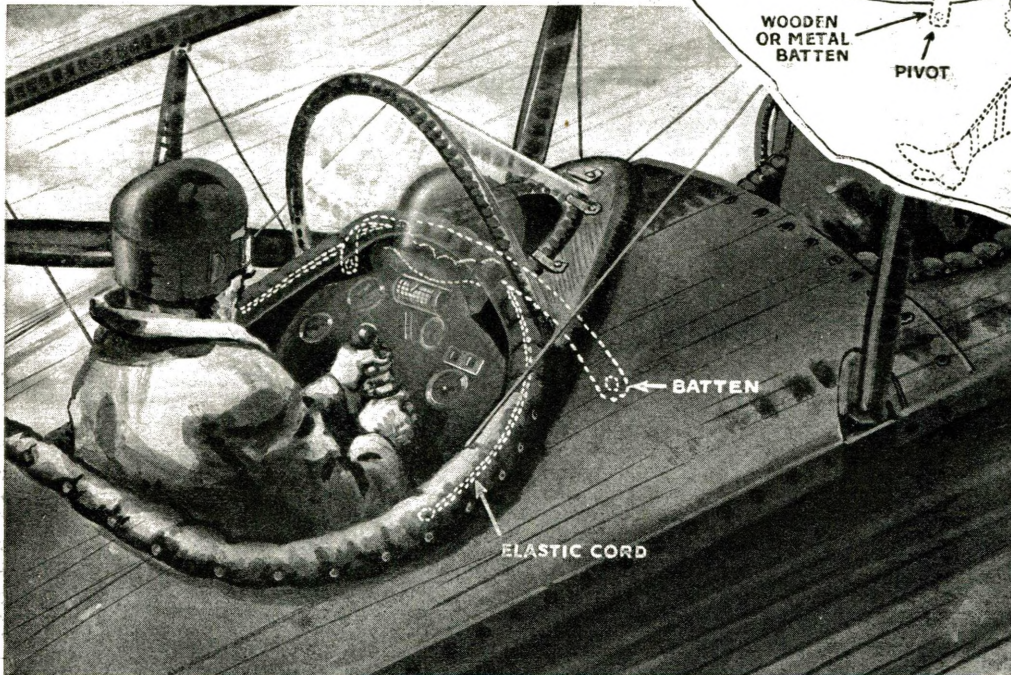

New Collision Type of Cowl for Airplanes. The Aviator's Head is Shown in Phantom in the Position Assumed in Case of Collision.

most serious objection is that in case of a crash, the pilot's head will continue forward and strike the joystick or instrument board

with a wooden batten. This in order to hold its shape gives a certain amount of rigidity yet due to the yielding nature of elastic and

would be very difficult to crush it in a fall. One becomes surprised at the regularity with which the wooden frame fails.

Storm-Proof Windshield for Autos

The drawings reproduced herewith show the four different adjustments of the latest improvement in windshields, namely, the storm-proof vacuum windshield, not one of these four adjustments requiring more than a moment's time.

At Fig. 1 is illustrated the ordinary cold weather adjustment, the arrows indicating the passage of air thru the shield. The mild weather adjustment showing the ventilation of the interior of the car by suction is shown at Fig. 2. At Fig. 3 we see the warm weather adjustment, the arrows depicting the circulation of the air, and at Fig. 4 the drawing shows the storm-proof adjustment, the arrows indicating the disposition of rain, snow,

dust and also the ventilation of the interior of the car by suction. It will be interesting to observe the clear vision space between the outer sections of the windshield shown in the cut at X.

This shield, as its name implies, is thoroly storm-proof, adapting itself to all weather conditions with equally good results. Not only does it insure clear vision for the driver, but it provides draftless ventilation of the interior of the car, at all times.

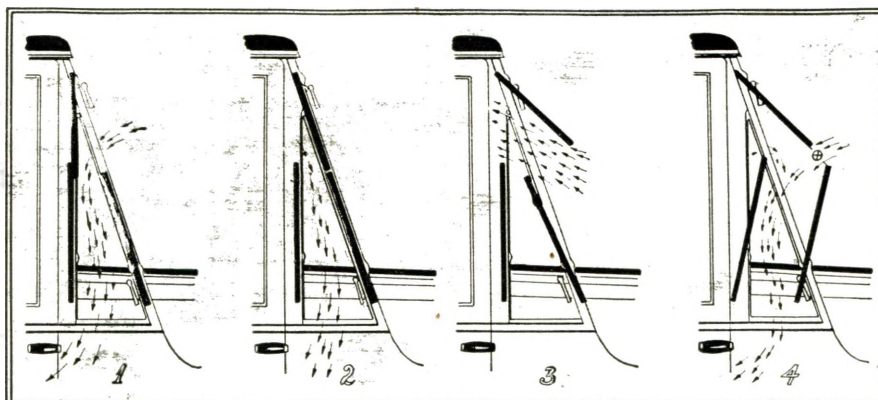

One of the Latest Innovations in Motor-cardom Is This Duplex Windshield, Which Can Be Made Storm-proof and Yet Provide Ample Ventilation, Simply by Manipulating the Component Parts of the Shield. The Arrows Show the Various Air Current Paths Which Can Be Provided at Will.

A clear vision space, not obstructed by the glass of the windshield, is maintained constantly on a direct line with the driver's eyes, regardless of whether there is a dense fog, a heavy rainfall, a snow storm, a wind gale or other similar weather disturbances, and yet, not a drop of rain, a flake of snow, nor a particle of dust can enter the car.

This innovation will without doubt prove itself indispensable to automobilists.

Filming Birds In Flight

WITH this newest rapid photography apparatus a Frenchman makes 250 pictures a second. This latest invention in moving picture cameras photographs moving objects with the aid of a flat mirror. By means of this ultra-rapid camera, invented by M. Labrely, the public will now see more details in moving objects, such as birds, animals, cannon balls, etc.

The new camera differs from all others. It is essentially composed of a flat mirror supported by a long handle set in a socket, which is attached to the lens with a tightening screw, thus making it possible to be turned around in any position. By the geometrical exactness of the mechanism, the optic axis and the focus of the lens is always at the desired angle with the mirror, whatever its position may be; it accurately follows the object reflected according to the angle of the lens and is always parallel with the plane of the lever, and can be turned to follow the remotest



With This Idea of a Reflecting Mirror, Which Can Be Quickly Attached to or Detached From a Motion-Picture Camera, a French Investigator, M. Labrely, Has Now Made It Possible to Take Very Rapid Animated Photographs, Such as Those of Birds in Flight, Two Specimens of His Ultra-Rapid Photography Being Shown at the Right and Left, Respectively.

corners for photographing. One of the photos shows the newest 250-picture-a-second motion-picture machine and the inventor, M. Labrely, showing clearly the position of the reflecting mirror.

The right and left hand strips of movie film here reproduced, show how accurately this new invention of M. Labrely photographs the flight of a bird; the strip of movie snapshots at the left showing the successive yet extremely rapid changes of the bird's wings, as he flaps them in his effort to keep afloat in the air. Perhaps, off-hand, you may not think this invention to be so very remarkable, as you recollect having seen an airplane in flight at the last "movie" show; but a bird flaps his wings very rapidly, especially a small bird, and an invention of this kind is not only of extremely great interest to the layman, for the wonderful novelty of the subject presented,—but particularly so to students of nature and naturalists everywhere.

The First Practical A. C. Dynamo

THE illustration shows a photograph of a dynamo which is among the earliest built by Professor Elihu Thomson. It is really the machine which called attention of the gentlemen who first, in Philadelphia in 1879, started to develop a business of arc lighting, based on the inventions of Thomson and Houston. The machine itself was constructed in its entirety by Professor Thomson. He made the patterns, had them cast, built the frame, made the field bobbins and wound them, and also wound the armature, made the connections thereto and all the machine parts of the machine itself. It weighed about 350 pounds and the base of the machine was bolted together and made of pieces of plank. It will be noted

that the field castings consist of two yoke pieces at the end, to which are bolted the horizontal field cores, four of which were used to save making a more complicated pattern. The two upper and the two lower field poles which meet in the center, are tied together by a piece of hard wood bolted to them. For lack of machine facilities, there is no boring or turning of the field or armature and the end yoke pieces were fitted to the cores by chipping, no planer being available.

One of the curious mechanical features is the cast-iron boxes receiving the shaft, which, strange to say, worked without heating during the running of the machine.

The machine was started in the fall of 1878 and by the end of that year was ready

to operate. In some respects it was unique. It really was a machine which could be coupled so as to give varying voltage and current. There were four field coils, which could be connected in series or in series-multiple, or the whole of them parallel, so that the virtual section of the wire was increased one, two and four. The same construction was adopted in the armature winding, there being in each of the two coils (which are clearly shown crossing each other at right angles) four separate wires which could be connected by a connection board, which is at the other end of the armature from that shown, so as to use wires in series, or in series-multiple or in multiple, and so varying the voltage

(Continued on page 908)

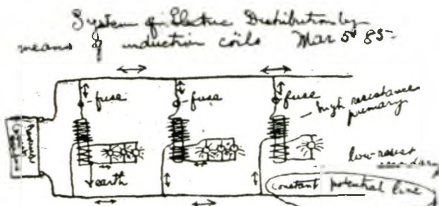

The idea is to have a constant potential source current (alternating) dynamo, feeding lines which remain at constant potential. Between these lines are connected a distribution coils with primaries of relatively high resistance, the secondary ends in low resistance and feed the light. Advantage is great saving of copper in mains and also self-regulation. The potential of the mains being quite high from 1000 to 2000 volts the fuses save the primary in case secondary is short circuited.

Interesting, indeed, is this original Hand-Written Memorandum From the Notebook of Prof. Elihu Thomson, Made in the Days When Electric Arc-Lighting Was in its Infancy.

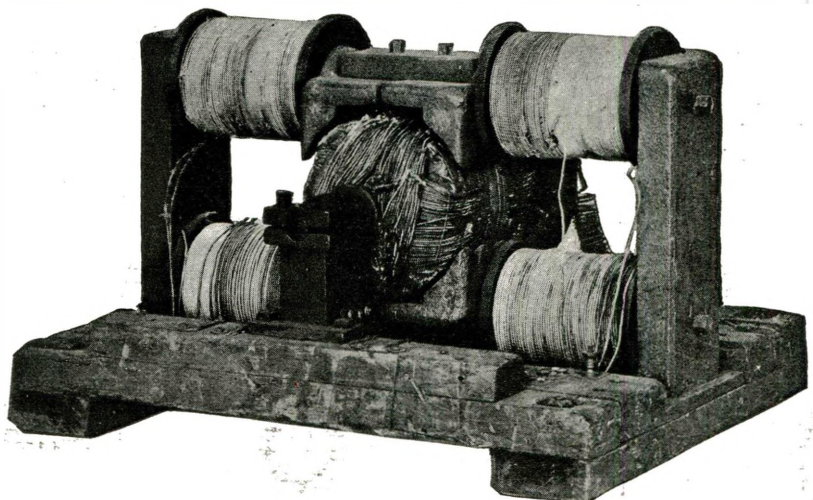

The Photo Above Shows One of the Very First Practical Alternating Current Arc-Lighting Dynamos Built by Prof. Thomson. He Made the Patterns, Had Them Cast, Built the Frame, Wound the Field Bobbins, and Demonstrated the Machine Successfully to the First Staff of Electric-Lighting Critics, Which Started the Present Industry on Its Way.

100 Years of Electro-Magnetism

Centenary of Ørsted's Discovery

By DR. ALFRED GRADENWITZ

FEW discoveries can be said to have exerted such a decisive influence on our scientific views as well as on the development of our economic life as Hans Christian Ørsted's epoch-marking discovery—that of the deflection of the magnetic needle by the electric current.

Previous to this great scientific achievement *electricity* and *magnetism* constituted two entirely separate realms of science, of relatively small extent and limited practical importance. Some scientists, truth to say, had occasionally believed that they noted some evidence of a correlation between those two forces of nature, but they had been unable properly to interpret these hints. Ørsted, who at the beginning of the 19th century, while yet quite young, had been entrusted with the professorship of physics at the University of Copenhagen, had by theoretical considerations been led to believe in the existence of such a correlation, and with admirable perseverance was endeavoring to demonstrate by actual tests the correctness of his theory. For his eventual success he is mainly indebted to the fact that so far from expecting a parallel action of the two forces, he rather supposed the magnetic effect of a conductor traversed by electricity, *to be radiating from the conductor*, in the same manner that light and heat will radiate from a conductor heated to incandescence.

On the basis of such views, Ørsted, in the beginning of 1820, again endeavored to seek the experimental proof of the hypothetical correlation. His first successful experiment was connected in a remarkable manner with his lecturing at the Copenhagen University. In fact, having just before the beginning of a lesson installed the apparatus for a decisive test, his conviction in the course of the lecture gradually became so strong that he eventually asked his hearers to proceed to



Hans Christian Ørsted, Who Discovered That an Electric Current Passing Thru a Conductor Would Deflect a Magnetic Needle. This Year Marks the Centenary of Ørsted's Epoch-Marking Discovery, Which Formed the Basis of the First Practical Investigations of the Electro-Magnet.

his laboratory in order there to witness the final test. This is how the great discovery was made during a lesson, in the presence of the whole crowd of his hearers, all of whom could satisfy themselves of the *deflection of the magnetic needle by the electric current*. The effect, truth to say, was at first rather weak on account of the weakness of the current, but some months after-

ward Ørsted, with a battery made up of 20 cells, was able to obtain much more intense effects and to investigate these in all detail. On July 21, 1820, he sent out to the scientific world of his day a short circular in Latin "*Experimenta circa effectum conflictus electrici in acum magneticam*, where all the fundamental experiments and results were explained.

Ørsted did not content himself with investigating how the magnetic needle would move, when keeping the conductor in various positions with regard to it: he also showed the effect—in opposition to the electrical effects so far known—to penetrate, unweakened, it would seem, the most various materials, *insulators* as well as *conductors* of electricity. He further showed that the magnetic field does not exert any effect on a needle of non-magnetic material, such as brass or glass.

It is perhaps not quite so easy to understand Ørsted's original memoir, the author using the rather unusual word "*conflictus*" to designate the electric current. Quaint and antiquated tho this appears at first sight, it will be found singularly significant in the light of modern theories of electricity, according to which electric particles or "electrons" moving to and fro in the interior of conductors, by their impact, produce what we call electrical phenomena.

It would be too tedious to point out here even the most important consequences Ørsted's discovery has had on the further development of electricity.

In the first place, it, of course, made possible the construction of an electrical telegraph, but this was followed by the whole series of marvels achieved by electricity, the applications of low tension as well as high tension currents, apart from electro-chemistry, being ultimately based on Ørsted's discovery of the mutual effects between electricity and magnetism.

Facts About General Electric Works

By CHARLES M. RIPLEY, E. E.

The Simple Facts:

(1) In 1918 the Schenectady shops of the General Electric Company, USED over 66,000,000 kilowatt hours of electricity.

(2) The number of shop employees last year averaged approximately 21,500 men and girls.

(3) A kilowatt hour of electricity is equal to the work done by a big draft horse working for 1 1/3 hours.

(4) A horse can do the muscle work of ten men.

These are all the facts used in this article.

Here Are Some Thoughts:

Dividing the amount of electricity used by the number of workers, we see that last year the average employee used about 3,100 K. W. Hours.

This amounts to 4,150 horse-power hours, in round numbers.

Express differently, it means that the electricity furnished last year, to assist each man and each girl was equal to the energy of one horse working 4,150 hours; or 4,150 horses working for one hour:

For every employee in the Factory.

Now for the Imagination:

QUESTION: How many horses were working for each employee right along, while he was busy on the job?

ANSWER. A team of horses worked 9 hours per day—every day of 1918, to assist each employee.

This is obtained as follows: 4,150 ÷ 2,700 equals more than 1.5 horses working during a 9-hour day—continually, as long as each man worked; so a big draft horse, and an ordinary \$250 horse, worked for the average employee.

Now, the draft horse does the "muscle"

work of ten men: so last year every hour and every minute, there were 15 imaginary men working for each actual employee in the shop. The electricity used last year by the average worker equalled the work of 15 Roman slaves—ALL YEAR—working every minute for each man and girl on the job!

If that many REAL MEN had been employed to assist skilled workers in the factory, and if they had been paid as much as the average worker was paid, the cost of electrical machinery, supplies, sockets, lamps, etc., would be roughly 16 times as great as at present.

An electric light socket instead of costing 30 cents would cost \$4.80!

An electric toaster would cost \$75 and a few of us would buy electric fans at \$150 each. Then we would all be burning kerosene lamps or candles.

"Movie" Models Show How Machines Work

By ESTHER LINDNER

EVER so often, almost everyone gets a distinctly bored streak—a time when, figuratively, if not literally, he sits down, folds his hands, and with a shake of the head mournfully sighs that "indeed there is nothing new under the sun."

Recently it is our old friend "the movies" that is supplying a brand-new jolt. And these same movies that formerly were noth-

How Cardboard Models, Progressively Photographed, Illustrate Machine Action

rate than this, and goes many steps further, for it is a mechanical contrivance, an exact working replica, of a machine or a piece

cate, cut to the proper proportions. These are pieced together, with working joints of brass rivets. When an exact fibre-board interior of the machine is complete it is placed within the pieces representing the exterior, which are in turn hinged, riveted and jointed, just like the original.

Artists who are specialists in making paper look like metal color and shade the completed replica. This matter of making fibre-

One of the Latest Ideas in Educational Movies Is Illustrated in the Accompanying Photographs. All of the Parts of This Particular Vacuum Gasoline-feed System for Automobiles Are Made in Dummy Form Out of Cardboard or Similar Stiff Material. Each Part Is Accurately Cut Out and Shaded by Artists So as to Appear Like a Casting and Pivoted by a Pin When Necessary. By This Means the Levers Can Be Moved Into Successive Positions and Photographed.

View Below:—Pipe from Bottom of Vacuum Tank Carries Gasoline to Carburetor. Pipe From Top of Vacuum Tank Connects with Intake Manifold. Suction in Intake Manifold Creates Partial Vacuum in Vacuum Tank, Drawing in Gasoline from Main Tank. Float Rises as Gasoline Rises Until Valve A Closes, Shutting Off Suction, and Valve B Opens, Allowing Air to Enter Vacuum Tank. Gasoline Pressure Then Opens Lower Valve C and Gasoline Flows to Lower Tank D and Thence to Carburetor. When Float Drops Valve A Opens, Starting Suction.

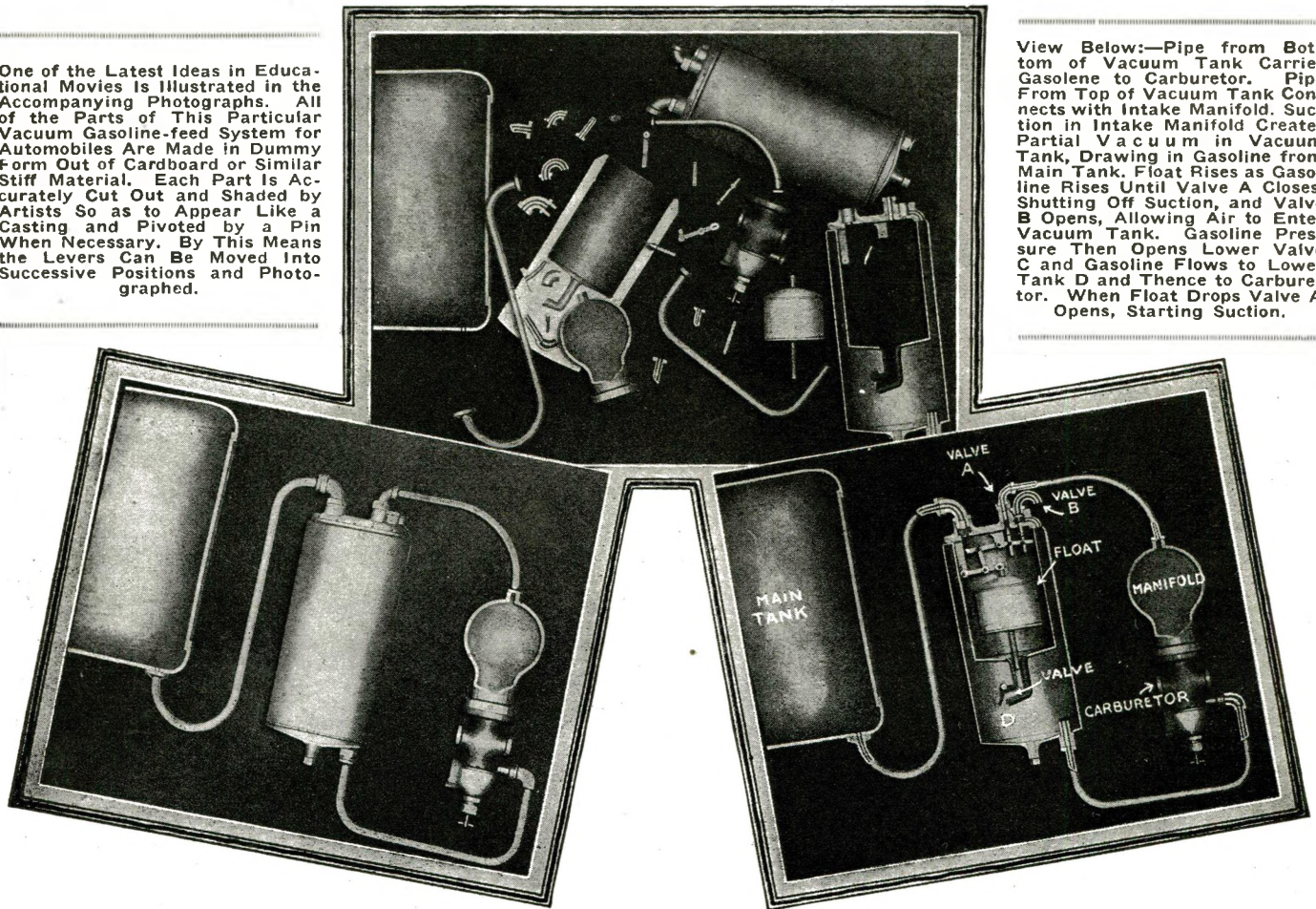

ing more nor less than a medium for entertainment have been supplying some very big steps toward progress in the scientific world. Every youngster loves to know "how the wheels go round"—and this is directly applicable to every youngster between the ages of fourteen months and eighty years or more.

It has remained for a motion picture inventor to hit upon a system of helping even the most unskilled mechanic to "watch the wheels go round"—to take any type of machine apart, look at it, and put it together again without the necessity of getting into soiled overalls or sweating or fuming or fussing over it. All that is necessary is for him to settle down comfortably in a seat in a motion picture theater. Thru an elaborate invention known as the *Mechnigraph*, invented and perfected by Howard Greene, we are now initiated into the "inside workings" of the machine.

The "animated cartoon" has been the medium heretofore for presenting on the screen, by means of moving line drawings, such explanatory bits as cannot adequately be shown in any other way.

The "mechnigraph" is much more elabo-

of mechanism, and it is made out of a specially prepared fibre-board. It moves just as the machine moves, and does all the things the machine does when it is in operation. And it has the added advantage of being moved and operated at the will of its maker—and the motion picture camera can be placed close to it, without the slightest danger, so that the most intricate bits of action may be clearly shown.

The making of the replica is more intricate than the planning of the most elaborate "cut-outs" that so delight children.

The actual machine is studied from every available angle—taken apart, put together again, watched carefully while it is dormant, and while it is in action.

From the specially prepared fibre-board is cut an exact duplicate, greatly reduced, but made to perfect proportion.

First an exterior view is cut out, with all details complete—front, back, joints—just as tho the actual model were being fashioned.

Then another set of parts, this time of the interior, is made. For each little section, each piece of wire, each separate part of the original, there is a tiny fibre-board dupli-

cate, cut to the proper proportions. These are pieced together, with working joints of brass rivets. When an exact fibre-board interior of the machine is complete it is placed within the pieces representing the exterior, which are in turn hinged, riveted and jointed, just like the original.

Often hundreds of pieces go into the making of one of these duplicates, and each one of them must be absolutely correct in every detail, for the duplicate, when it is shown on the screen, is magnified hundreds of times. A tank that is made to measure ten inches in height in cardboard appears ten feet high when thrown upon the screen; and an error in its making that would be practically invisible to the naked eye shows up on the screen a glaring inaccuracy.

When the fibre-board machine is complete the most difficult part of the operation—the animation—begins. Each movement requires

(Continued on page 912)

Popular Astronomy

By ISABEL M. LEWIS, M.A.

of U. S. Naval Observatory

THE earth, as is well known, is not a perfect sphere in form. As a result of rapid axial rotation it is flattened at the poles and bulging at the equator. In the words of the mathematician it is an oblate spheroid of revolution and the amount of its polar compression is $1/297$ th of its equatorial

Has the Earth's Rotational Period Changed?

poles with zero rotational motion of the surface the centrifugal force is also zero.

at the equator would possess no weight whatever and a greater speed would send it flying from the earth's surface tho in midlatitudes objects would still possess very appreciable weight because the rotational speed decreases with distance from the equator and, moreover, only one component of the centrifugal force, that di-

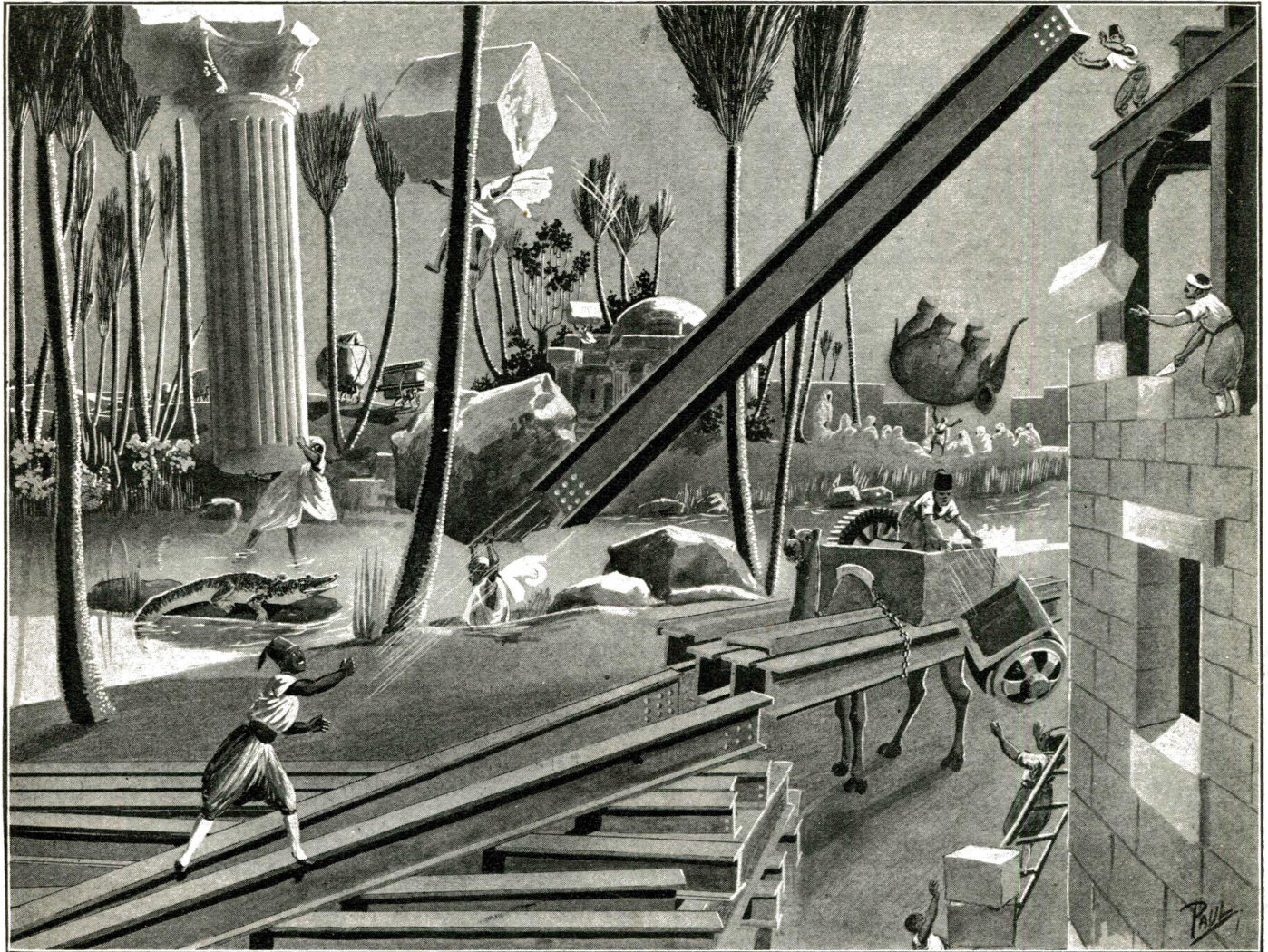

The Earth Rotates at the Rate of 24 Hours for Each Revolution. If It Were Revolving Approximately Seventeen Times as Fast, in Other Words, Making a Complete Revolution in 1.41 Hours, Instead of 24, Then, Due to Centrifugal Force, Objects at the Equator Would Weigh Nothing. The Above Illustration Shows a Scene Somewhere Near the Equator Under Such Circumstances. It Then Would Be a Simple Matter to Build a Sky Scraper, as All Materials Such as Steel Beams, Marble Columns and Any Other Building Material Could Be Tossed About as Shown. There Would Be Only One Trouble and That Is the Person to Whom a Steel Beam, for Instance, Was Tossed Would Have to Be a Good Catcher. If Not, the Beam Would Keep on Flying in the Direction in Which It Was Tossed, Never to Return.

radius or thirteen and three tenths miles. That is if we imagine a sphere described about the earth with radius equal to the earth's equatorial radius the poles of the earth will fall short of the corresponding poles of the sphere by about thirteen and three-tenths miles.

The more rapidly a non-rigid spheroid rotates the greater becomes the polar compression and the greater the equatorial bulge, and such rotary motion also produces a very appreciable effect upon the attraction of the spheroid of our earth for objects on its surface. The axial rotation sets up a centrifugal ("center-fleeing") force that is directly proportional to the *square* of the velocity with which the earth's surface is rotating. At the equator where the earth's surface is moving most rapidly the centrifugal force has its maximum value. At the

Moreover, centrifugal force acts in direct opposition to gravity at the equator and so its effect is to reduce the weight of a body at the equator, and to a less degree in higher latitudes, while at the poles it exerts no effect on surface gravity (See Fig. I.). So as a result of centrifugal force an object at the equator weighs less than it would weigh at the poles. At the earth's present rate of rotation the centrifugal force at the equator is $1/289$ th of gravity.

The more rapidly the body rotates the greater becomes this centrifugal force. Since it is proportional to the *square* of the rotational speed it is evident that it would equal gravity at the equator if the earth should rotate seventeen times more rapidly than at present, that is, if it turned on its axis in about one hour and twenty-five minutes. Under such conditions a body

directed away from the earth's center, is effectual in reducing gravity. At the *poles*, an object would possess *greater* weight on a rapidly rotating spheroid than on one rotating slowly. This is due to the fact that the flattening or polar compression increases with the speed of rotation of the spheroid and this brings objects at the poles nearer to the earth's center and the effect is to increase the earth's attraction. The nearer the earth's surface is brought to its center the greater the attraction of gravity. If the earth were rotating at the rate of one revolution in four hours, say, instead of in twenty-four hours, a man who now weighs 150 pounds at the equator and $150\frac{3}{4}$ pounds at the poles would weigh about 128 pounds at the equator and about 157 pounds at the poles. If the rotational speed increased to seventeen times its pres-

ent value a man would weigh *nothing* at the equator while at the poles he would weigh considerably more than he weighs there at the present rate of rotation.

There are two factors operative, then, in producing variations in the force of gravity for different points on the earth's surface—the centrifugal force and the consequent change of shape, involving polar compression, and their combined effect is to *decrease* gravity in equatorial regions and to *increase* it at the poles. The more rapid the rotation the greater the difference in gravity between the equator and the poles. As the rotational speed increases, objects at the poles *increase* in weight while in midlatitudes there is a point where surface gravity changes but slightly for different rates of rotation.

So far we have considered only the effect of an increased rotational speed upon the value of surface gravity and the changes that result in the weight of all surface objects.

Let us consider now what would be some of the effects upon the form and condition of the earth's surface crust arising from a considerable change in rotational speed.

According to the tidal theory of the origin of the earth-moon system it has been assumed that at one time in the far distant past the moon was much nearer to the earth's surface than at present and that the earth was then rotating rapidly in a period of four or five hours, the moon being driven back to its present position and the earth's rotational speed slowed down to its present value thru tidal reactions.

Assuming that the earth did at one time rotate on its axis as a solid body in a period of four hours or less, it has been shown by geologists that the changes in the condition of the earth's surface crust would have been so pronounced that the evidence would have been preserved even to the present day in the condition of the strata of the earliest geological ages.

If the earth were rotating in a period of four hours the polar flattening would amount to one-eighth. Thus the polar radius of the spheroid of that day would have been five hundred and fifteen miles shorter than its equatorial radius and about three hundred and forty miles shorter than the polar radius of today. A man would gain nearly 23 per cent in weight by moving from the equator to the poles. The equatorial circumference would have been about one thousand miles greater

dred and sixty-five miles in vertical height. Geologists estimate that a mountain range of the height of the Alps represents a folding or contraction of about seventy-four miles of the earth's surface and to dispose of an equatorial bulge one hundred and sixty-five miles in vertical height, which corresponds to an increase in equatorial circumference of one thousand miles over the present value, the crust would have to contract and fold gradually into the equivalent of twelve mountain ranges of the height of the Alps extending longitudinally across the equator.

It can be shown mathematically that the changes that would take place in the spheroid to adapt it to the longer rotation period of today would be effective chiefly in the equatorial and polar regions. The radius of the earth in 35° North and South latitudes would remain practically unchanged for all rotational speeds.

The crumpling of the equatorial bulge in the course of ages then would be taken up in the form of lofty mountain ranges stretching across the equator in a north and south direction and dying out in latitudes 35° North and South. It is very unlikely that all traces of the development of numerous lofty mountain ranges crossing the equator would have been completely obliterated by this time. As is well known three-fourths of the equatorial belt of today is *submerged* and the Andes, the one mountain range, that crosses the equator, is not confined to within 35° of the equator as required by the theory.

The changes in the condition of the earth's surface crust in polar regions as it adapted itself to a slowing down of the earth's rotational speed, should be quite as radical as the changes in equatorial regions tho opposite in kind. Instead of the shrinkage and compression of the earth's crust that would take place in the equatorial belt, accompanied by increase of pressure and tangential stress, there would be a gradual elevation and stretching of the crust in the polar regions along meridional lines as the flattening at the poles gradually decreased and the curvature and swelling of the surface increased. A state of tension of the surface would exist in high latitudes which would rapidly increase toward the poles and which would manifest itself in a radial gaping and fissuring of the surface. In equatorial regions there would be a gradual increase in surface gravity and in pressure and tangential stress which would be adverse to volcanic action, while in

to the geologists, no difference in the characteristics of the sedimentary rocks of the Archæan Era, which are the earliest known rocks, for different latitudes. The rocks of that era possess the same characteristics in all parts of the world which would certainly not be true if the earth's surface at that time was being subjected to an increase of gravity and compression in equatorial regions and a decrease of gravity and surface tension in polar regions.

There should exist, moreover, geological evidence that the polar regions were deeply submerged in that era. If the earth's axial rotation were then much more rapid than it is at the present time, the surface at the poles would be far more flattened than it is now. The elevation of the polar surface would have increased by many miles during the intervening ages. As a matter of fact the lands of the earlier geological ages that are best exposed and longest out of water are those in the polar regions and there is no geological evidence whatever that a gradual increase in the curvature of the earth's polar surface has been going on thru the ages.

So tremendous would be the surface changes brought about thru the remodeling of the earth from a spheroid of revolution with a rotation period of four hours and a polar flattening of one eighth to a nearly perfect sphere with a flattening of only 1/297th, and a rotation period of twenty-four hours that they could not escape preservation in the geological records of the earth's early history.

The theory that the moon was originally thrown off from a rapidly rotating earth-mass thru centrifugal force and that the distance between the two bodies was gradually increased and the earth's period of rotation gradually slowed down thru tidal reactions between the two bodies, was developed upon the assumption that the earth was formerly and is now a *viscous* body. Since the tidal theory was first developed it has been proven in a number of independent ways that instead of being viscous the earth is highly elastic and that the tides developed in the earth-mass by the attraction of the moon are of the nature of elastic strains and that neither now nor in the far distant past have they had any appreciable retarding effect upon the period of the earth's rotation.

It has also been proven mathematically that the effect of the tides raised in the earth's atmosphere and in its surface waters by the gravitational attraction of the moon

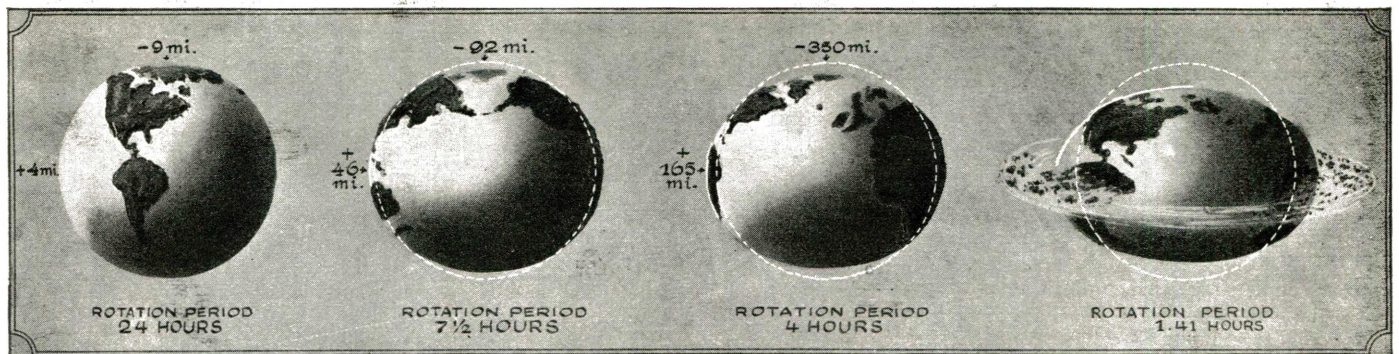

Our Earth Bulges About Four Miles at the Equator and Is Flattened About Nine Miles at the Poles, Due to the Rotational Speed of the Earth, Which at the Equator Is 1039 Miles An Hour. If the Earth Were Standing Still, the Globe No Doubt Would Have Been a Perfect Sphere. The Other Illustrations Show the Equatorial Bulge of the Earth and the Polar Flattening As the Earth Increases Its Rotational Speed. If It Were to Make a Complete Revolution In 1.41 Hours, the Bulge Would Become So Great That Objects Near the Equator Would Begin to Fly Off As Shown In the Last Picture, and As a Matter of Fact the Earth Would Begin to Break Up at Such a Tremendous Speed. Chances Are That the Earth Before It Had Cooled Revolved At a Different Speed Than It Does Now, But All Geological Data Point to the Fact That the Earth's Rotational Speed Has Neither Increased Nor Diminished Appreciably During the Ages.

than it is today which would correspond to an equatorial bulge of one hundred and sixty-five miles in vertical height above the present surface of the earth.

To mould the earth to its present form it would have been necessary for the equatorial belt to contract gradually one thousand miles in circumference and one hun-

dred and sixty-five miles in vertical height. There is, however, no evidence that volcanic action was more prevalent in high latitudes in the earliest geological ages than in the equatorial belt. There is, according

are practically negligible in their retarding effect upon the earth's rotational period.

Moreover, if the earth had formerly rotated in a period of four or five hours and the moon were then much closer to the earth than at present the tides raised in the ocean by the attraction of the moon

(Continued on page 892)

Home Electrics

NEW ELECTRICAL "FIRELESS" STOVE.

By DR. ALFRED GRADENWITZ

An ideal kitchen apparatus that will prove a boon to harast housewives is here

This New Electric Fireless Cooker is Provided with an Automatic Switch, Which Cuts Off the Current from the Heater as Soon as 100 Degrees C. is Reached—That is as Soon as the Food Begins to Boil, and the Rest of the Cooking is Done by the Retained Heat in the Food.



illustrated and is an electrical outfit designed by a Leipzig engineer, Mr. R. Reinhold, for cooking, roasting, baking, sterilizing, etc. Tho sufficing for a fairly large family, it only consumes trifling amounts of electricity, just a few cents during three hours' working, an additional advantage being that the food will never burn or boil way.

The heat required for cooking, of course, is just 100 degrees C., any excess being a waste of energy. The new apparatus, accordingly, is designed for having an automatic switch to cut out the current as soon as 100 degrees C. is reached; that is, as soon as the food begins boiling.

Inasmuch as the apparatus, like an ordinary "fireless stove," is surrounded by poor conductors of heat, the food will go on cooking for some time without any further supply of heat. As the temperature then drops somewhat, the current will be thrown in again automatically, thus keeping the heat continually at 100 degrees C. The food accordingly will go on cooking without any interruption, and as there is no excess of heat, there will be no risk of burning.

The result obtained by this automatic control is that during three hours' cooking there will only be a consumption for about 46 to 60 minutes of current.

Moreover, this apparatus is fitted with a clock switch that can be adjusted to any given time and at the moment desired it completely and definitely cuts out the current. If a dish of peas requiring three hours to become soft is put into the cooker, the switch is adjusted to three hours, thus preventing any excessive softening, tho the "fireless stove," that is to say, the heat-insulating material surrounding the pot, keeps the dish ready for use at a minute's notice.

If, for instance, the housewife at any time in the morning, after getting everything ready, puts the dish into the apparatus, she has only to adjust the clock to the proper time for cooking the food, after which she need no longer trouble herself about it until the time for serving the dish.

However, the electrical "fireless stove" possesses a further advantage:

"Cooking without water, roasting without fat" has for some time been recognized as the only rational culinary method, according to which potatoes and vegetables, without any addition of water and meat, fish, fowl, etc., without any fat, are put into a paper bag and cooked or roasted there, thus allowing all nutritive constituents of the food to be preserved and obtaining dishes more savory as well as more nutritive. Now, as this process obviously can only be resorted to if provision is made never to exceed a given temperature, the apparatus above described lends itself admirably for the purpose.

The apparatus consists of a wooden case lined with poor conductors of heat, and containing in its interior a metal box inside of which are 4 pots.

JAPANESE MAKE TEA ON ELECTRIC HEATER.

In Japan, the land of the most insatiable tea drinkers in the world, they've discov-



100V. 5A. 上下回轉 180 度 家庭用火鉢

It Took a Clever Oriental from the Sunny Island Empire of Nippon to Find a New Use for the Electrical Reflector Heater. Thousands of Which Are Now Being Daily Adopted. Simply Place the Reflector in a Horizontal Position by Means of a Swivel Joint and Place Your Tea Pot on Top of the Wire Guard, When, Presto! You Can Make Your Tea (or Coffee) in a Few Minutes.

ered a new way of making tea. A radiant electric heater of the reflector type is tipped up so that the wire guard is on top. Then the inventive Orientals set their tea pots in the center of the guard.

Might not the Occidental boarding house girl of proverbial fame discard her obsolete gas jet and do her cooking the new electrical way? The accompanying photo was taken of an advertisement in a Japanese paper.

It takes an Oriental to use his wits in figuring out a new use or a new way to use an old apparatus or device. This is not because he has not the money to pay for whatever he may need at all, but illus-

trates once again, their proverbial economy, which we of the Western Hemisphere are wont these days, to disregard entirely, or at least to a great extent. The children in the Oriental countries are trained constantly to practise economy, and to their credit, it can be said that practically never do they display extravagance, either in their homes or in their social activities.

Contributed by ARTHUR P. HIROSE.

IT'S HERE—THE ELECTRIC BUTTER CHURN!

The new electric buttern churn possesses some very clever and exclusive features, namely, a complete housing over all moving parts, and is directly driven off the motor by means of a worm gear, using a friction gear to prevent burning of motor in the event dasher is retarded or held, also to avoid stripping of gears. The entire mechanism is arranged and attached to the cast plate which forms the left side of gear housing; and by simply removing the plate the complete driving mechanism rests in one's hand.

The base of the churn is stained wood, supporting three iron uprights which in turn support the driving mechanism mounted on a T-shaped base. Suitably located on the base are three pins which keep the earthenware container in proper place.

The container is a double-glazed stone jar with suitable side handles, making it easily handled and cleaned. It has a close-fitting top, rendering it impossible for cream to splash out.

The dasher includes a dash rod of aluminum, which cannot rust or corrode and is easily kept clean.

The machine is designed for home use and will churn from one-half to three and one-half gallons at a time. It can be equipt with motor, either for 110 volts alternating current or direct current, or 32 volts direct current.

(Continued on page 900)

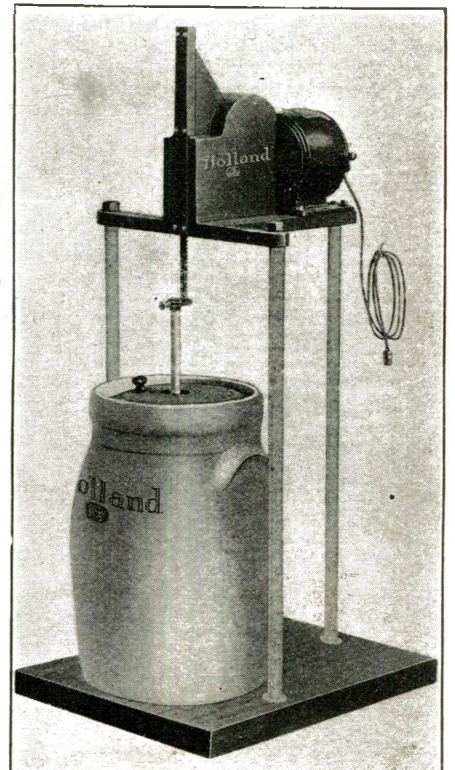

Attractive New Form of Electrically Driven Butter Churn. This Churn Will Produce Butter in a Very Short Time with the Utmost of Cleanliness—and Besides, It Is Not Noisy, Nor Does It Require a "Tip."

MOTOR HINTS

FLOOD-LIGHT IN FRONT OF RADIATOR

First Prize \$25.00

Place an electric lamp, with reflector, in front of radiator. It can be clamped on buffer or cranking-axle projection, springs or any available place so that the light rays are turned against the front of the auto or truck.

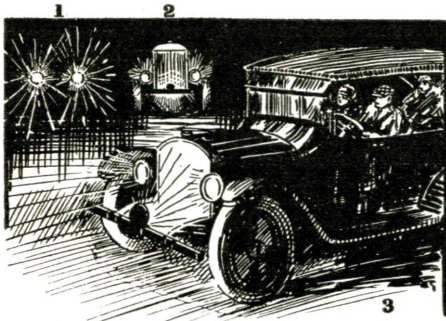

"No-glare" Flood-light Suggested for Use on Front of Automobile. The Headlights Light Up by Reflection. The Rear View Image Is a Silhouette.

Fig. 1 shows usual effect of an approaching auto. Fig. 2 shows the front of auto lit up by such an in-facing lamp as above described. Fig. 3 shows how the light may be placed on buffer.

Some headlights have no dimmers and the laws require that strong lights be shorn of their blinding glare, so that a lamp as described will shine into the regular headlight reflectors and on the radiator, thus preventing accidents to pedestrians and other autos, as well as safeguarding the car so equip.

Contributed by GUS WEST.

RAIN PROTECTOR FOR WIND-SHIELD

Second Prize \$15.00

During the rainy season a great many accidents are due to the poor vision thru the wind-shield. Why not make a protector for almost nothing and avoid accidents? It can be made with either celluloid or card-board. First cut it into the shape as shown in Fig. A. It can be any size, but about 8 inches by 12 inches is best. Then place strip of tin edge as shown and solder the hook at the middle. Hook the protector on the top of the wind-shield rather tight and all is done. If the protector is made of card-board, thoroly paraffin it, and it is not a bad idea to make several and keep them in auto and change once in a while.

Contributed by ROBT Y. MATSUMOTO.

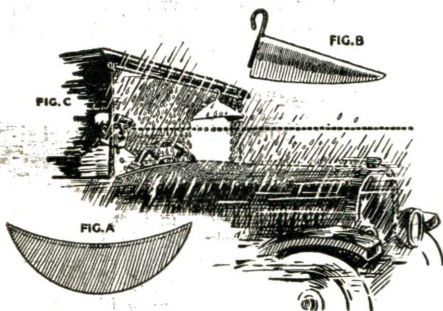

At Last a Simple and Effective Rain-shield, Attachable to the Wind-shield in the Manner Shown.

\$50.00 IN PRIZES

Paid for "Motor Hints."

Most of our readers have a car of their own, and any number of them have made certain improvements on that car. We want to know about these improvements. What we want are PRACTICAL ideas, not freak stunts. The idea should be simple enough, so that anyone handy with tools can duplicate it. Note that the idea does not necessarily have to be electrical in any way.

We would like to have a photograph of the stunt showing that it was actually tried, but this is not absolutely necessary to win a prize. A simple sketch will do showing the essential parts, etc.

We will pay the following prizes each month:

FIRST PRIZE.....	\$25.00
SECOND PRIZE.....	15.00
THIRD PRIZE.....	10.00

All other accepted articles, which win no prizes, will be paid for at the rate of \$2.00. Articles submitted should not be long ones. About one hundred to two hundred words will suffice. Address all manuscripts to Editor, "Motor Hints," care of this publication.

A RIM REPLACEMENT

Third Prize \$10.00

Everyone who owns a car which has detachable rims has been out and had the not-wisht-for blowout. You don't mind very much the trouble taking off the rim and mending the tube, but when it comes to the trouble experienced in making the ends of the rim "meet," you stop—give up

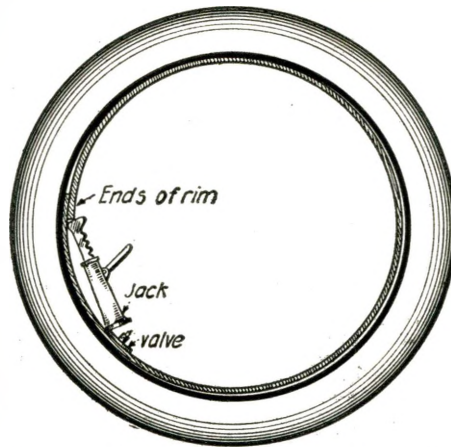

One Way of Replacing Auto Tire Rims With a "Jack." If the Valve is Not in a Suitable Position a Special Hole Can Be Drilled and a Bolt Inserted in It Temporarily.

a while, and then again worry unnecessarily; maybe you know the old strip of wood stunt which is merely a get-by and one which gives results enough to get you work half a day, but the stunt shown here-with is completely explained within itself. But, to be sure you understand this feat, I am going to explain a little.

Set your jack on the rim where the valve comes out (here you will find a little hump which will prevent the jack from slipping) and the other end against the rim that laps over; now tighten up on your jack and tap the rim with a hammer or wrench, pulling your best at all times on the jack; you will easily put the rim together properly in this way. If your valve does not set right for your jack to push on the end of the rim, you must drill (or have drilled) a hole in the rim the proper distance and put in it a bolt or something until the rim is together.

Contributed by TROY F. WATTS.

"DIRECTION INDICATOR" FOR CHAUFFEUR.

Procure a small piece of wood, large enough to accommodate three small lamp sockets. Then screw four screws on to it to serve for binding posts. Three lamps—one red, one white and one blue, are used. The red one will indicate to the (left); the white one (ahead), and the blue one to the (right). The lamp board is screwed to the dash board.

Next obtain a piece of wood of a size for three push buttons and screw them on the side of the car, with four screws for

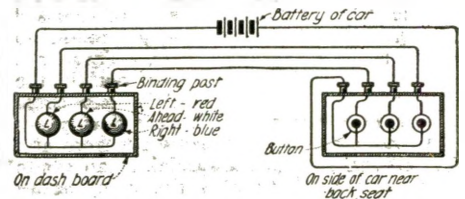

Simple Direction Indicator for Use on Motor Cars.

binding posts. Screw this in a convenient place in reaching distance of the arm. Connect wires as shown in diagram. This device is very successful and your chauffeur will be greatly benefited.

Contributed by ANDREW M. SCHROEDER.

AUTO-TRANSFORMER FOR FORD HEADLIGHTS

Being somewhat annoyed with the system of the Ford lighting circuit when one light goes out, whereby both became inoperative, I hit upon the plan of placing an auto-transformer in the lighting circuit that would not materially drain on the magneto and still permit one light to burn, even tho the one bulb may be blown.

Cut thin sheet iron in strips to the following dimensions: Two piles 1/2 inch wide and 1 inch high and 1 1/2 inches long. Also two piles 1/2 inch wide and 1 inch high and 2 1/2 inches long.

These are shellacked and dried and built up in the usual dove-tail fashion.

Make two coils wound in the same direction on one long leg. Each coil contains 120 turns of No. 20-gage insulated wire, and are connected in series; series connection is brought out to a binding post.

An auxiliary winding for the tail or dash-light of a voltage lower than that of the magneto so as not to use excessive pressure, namely 18 volts. This winding is on the remaining long leg of the transformer. No. 20-gage wire is used for this also and the required number of turns will be 17 times the voltage of the lamp. I used a three-volt lamp, being suitable for a small battery when the motor is not running. Seventeen times three volts equals 51, the number of turns required for the three-volt tail lamp.

Contributed by ROBERT L. SMITH.

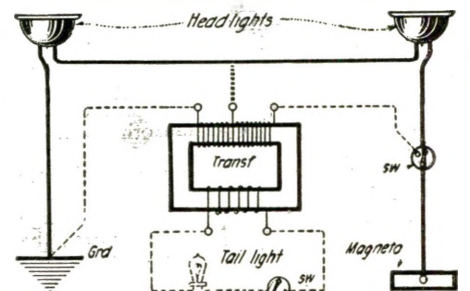

Wiring Diagram With Home-made Auto-transformer for Ford Headlights, Permitting One Lamp to Burn if the Other Goes Out.

Heat for the Household

By H. WINFIELD SECOR

Associate Member of the American Institute of Electrical Engineers

EVERYONE today, whether he be rich or poor, or resident in city or country, is bound to be interested in the best and most economical kind of fuel to use for heating the home. Of course, the standard fuel for heating residences and buildings in general, is hard or anthracite coal as it is correctly known. Soft coal is generally used by railroads, factories and ships only. For residence heating, the anthracite or hard coal is the most satisfactory all around fuel, providing you are lucky enough to obtain a good grade of coal. There are seventy-five different grades of coal in the American market alone. Coke has come greatly into favor in the past few years as a source of fuel for house furnaces and even stoves, in which a special, small grade of coke is used or also the compromise idea—a mixture of small coke and anthracite.

Among the fuels which have been and are being used for residence heating, either in part or in whole, are crude oil—used by blowing into furnaces; kerosene or coal oil burners placed in stoves such as kerosene ranges, in the same fire-box as that previously used for coal; electrically heated range boilers; coal dust or other coal briquettes, and electric radiators or stoves. All of these are shown in the accompanying illustration, besides several other features of economical importance such as well-fitted storm sashes and the relative bulk and heating value of coke, coal, wood, etc. These will be described in order.

Oil Instead of Coal for House Furnaces

A number of suburban residences, some of which in the vicinity of New York, were inspected by the writer, have arrangements installed for burning heavy fuel oil instead of coal or coke. The arrangement of the oil container or tank outside of the house is shown at Fig 1. The tank can be placed in the cellar, but it is safer, of course, out-of-doors. The tank is provided with a filling pipe which extends above the ground and is provided with a suitable airtight cap.

Instead of loading dirty coal into the cellar and carting away a still messier load or loads of ashes from time to time, there is nothing to be handled whatever with this system. The oil is fed into the furnace by gravity or under air pressure so as to give a blast effect in the fire-box. The relative cost of this system of heating ranks very well with the cost of furnishing coal or coke, and all the bother of shoveling coal and handling the everlasting ashes is done away with.

Kerosene burners for ranges and stoves: As a substitute for coal or coke in the kitchen range or other stoves, there has been developed and marketed for several years, a very clean and highly efficient source of heat in the form of a kerosene gas burner, or pair of burners, provided with a suitable length of feed pipe connected to a tank which is placed on the wall or in a closet, or in any other out-of-the-way place.

The writer has seen these burners in use and it is surprising what a fine blue flame blast of heat they provide, heating the range and water box much more quickly at the start than with coal or other fuel, and proving also more economical in the long run, as those who have used the blue-flame wickless oil stoves have had occasion to note already.

The Comparative Heating Value of the Various Household Fuels

Electric Heater for range boilers: The illustration at Fig. 3 shows an electric heater especially devised for insertion in kitchen range boilers in the manner shown. This heater, several types of which are on the market, comprises in most cases, a thin metal tube such as copper, inside of which there is placed an electric heating coil or grid. A high thermal efficiency is claimed for this particular form of elec-

THE accompanying article describes the various fuels available for heating of residences and features some of the newest sources of heat such as fuel-oil, coke and electric heat. The use of coke has greatly increased in the past few years and some householders have found it efficient even in the smaller stoves. However, it usually works best in the small stove, unless it has an exceptional heavy fire box, when mixed about half and half with coal.

With the best grade anthracite coal, the best quality coke gives about nine-tenths the same heating value. Coke requires about twice the storage space of coal, ton for ton. Recent scientific tests in the laboratory have shown that a ton of coal may be considered as the equivalent in heating value of one cord of heavy wood or two cords of light weight wood.

Among the other features of prime interest to the householder, with the rapidly mounting cost of fuel, which are discussed in the present article, are the use of storm sashes, electric fans for improving the furnace draft, and numerous other features often disregarded by those seeking the highest economy in fuel saving

tric boiler heater, owing to the fact that a high percentage of the heat produced is transferred directly thru the thin metal wall to the water, and practically none of it can escape by radiation outside of the boiler, which is the case with sensibly all other forms of heat applied for warming water in a boiler, either directly or indirectly.

Relative Heat Value of Coal, Coke and Wood

We often hear some heated arguments as to the relative cost and heating values of coal, coke, wood and other fuels. It is somewhat difficult for the layman to figure out the comparative cost of operating a stove of furnace for these various fuels, and the calculation required for the comparison of electric and oil heating is such a variable and complex one, that the suggestion is here given that for oil or electric heat, the householder had best make some inquiries of neighbors or friends who have used, or are at the present time using one of these specific sources of heat.

The relative heating values of coal, coke and wood are, however, quite well known, and those interested in this subject, will find a wealth of information given in *Kent's Mechanical Engineers Handbook*, or other engineering text-books covering various fuels and their heating values.

The heating value of various fuels is expressed by the number of heat units realized per pound of fuel burned. The best hard or A-1 anthracite coal, such as that which is produced from the Pennsylvania coal mines, yields 14,000 B. T. U's or heat units per pound. The best grade of coke, made from coal of selected grade, gives but 12,600 B. T. U's per pound. We can therefore see at once, that if we burned one pound of A-1 high grade anthracite coal, and one pound of the best coke obtainable, on a test run in a furnace or boiler, the coke will show only nine-tenths the heat efficiency of the coal. Many people are misled on this point and believe the coke to be more efficient than coal, but this fallacy is easily explained by the fact that it is very difficult to obtain the very best grade of coal to-day, and it frequently happens that coke appears in a much better light with regard to efficiency and heating value when compared to the low grade coal.

One has to go easy when attempting to burn coke in furnaces or stoves not intended for its use, as it is liable to burn out the fire box or warp the top of the stove or other parts very badly, in fact cracking them in some cases. If the stove or furnace does not appear to be sturdy enough to stand the intense heat produced by the free-burning coke, it is the best practise to endeavor to mix the coke about half and half, with coal. A mixture such as this is the best in all instances, for stoves and particularly kitchen ranges, but recently several large coke producers have marketed various sizes of coke, corresponding to all the sizes of coal commonly known, such as pea, egg and nut. They recommend the small sizes of coke for use in the average size stove, etc., but you will find the best conservation, so far as prolonging the life of the stove is concerned, is to mix coal and coke. Coke weighs about 28 pounds per cubic foot for standard size, while anthracite coal weighs about 50 pounds per cubic foot. It will be seen therefore, that a ton of coke will require twice the volume or cubic feet of space, occupied by a ton of anthracite coal.

According to tests recently conducted by the Forest Products Laboratory at Madison, Wisconsin, two pounds of dry wood of any non-resinous species, have about as much heating value as a pound of good coal. In terms of tons and cords—a ton of coal may be considered as the equivalent in heating value of one cord of heavy wood, or two cords of light weight wood. One cord, or 128 cubic feet of hickory, oak, beech, birch, hard maple, ash, elm, locust, long leaf or cherry is equivalent to one ton of coal. One and one-half cords of shortleaf pine, western hemlock, red gum, Douglas fir, sycamore, or soft maple equals one ton of coal. Two cords of cedar, red wood, poplar, catalpa, cypress, basswood, spruce or white pine equal one ton of coal.

Briquette Firing

The illustration at Fig. 5, shows briquettes in use as a fuel for stoves. Americans are not so familiar with this source of heat as are Europeans, for several reasons—probably due to the fact that coal is not so common or plentiful in European countries as it is here. In Ireland, for instance, they make fuel briquettes of peat or moss, which have a surprisingly high thermal value. Briquettes have also been made

(Continued on page 910)

HEAT FOR THE HOUSEHOLD

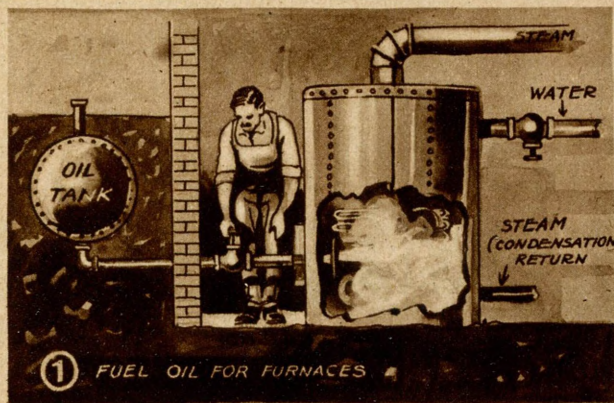

① FUEL OIL FOR FURNACES



② KEROSENE BURNER ON ORDINARY RANGE OR STOVE

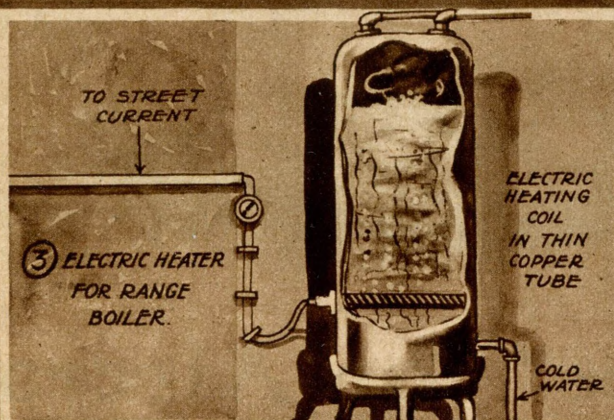

③ ELECTRIC HEATER FOR RANGE BOILER.

<p>2 LBS OF DRY WOOD = 1 LB. COAL IN HEATING VALUE</p> <p>OR</p> <p>1 TON COAL = 1 CORD (4'x4'x8' OR 128 CU. FT.) HEAVY WOOD IN HEATING VALUE</p>	<p>VOLUME COKE 2 TIMES VOLUME COAL</p> <p>HEAT VALUE 1/10 THAT OF SIMILAR WEIGHT OF COAL</p>
<p>④</p> <p>1 LB COAL UNIT OF (HEAT TAKEN) HERE</p>	

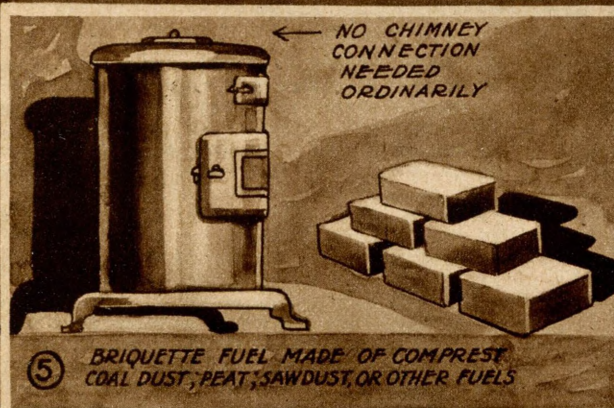

⑤ BRIQUETTE FUEL MADE OF COMPRESSED COAL DUST, PEAT, SAWDUST, OR OTHER FUELS

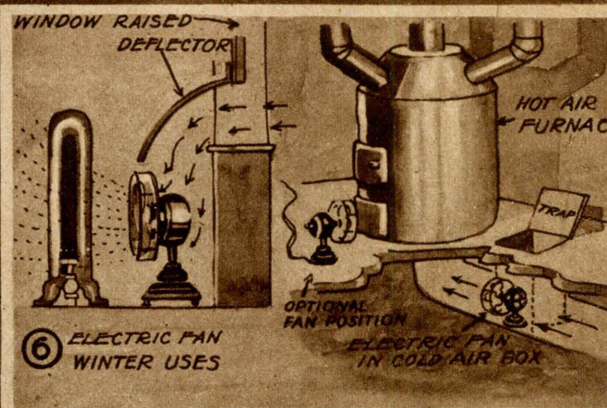

⑥ ELECTRIC FAN WINTER USES

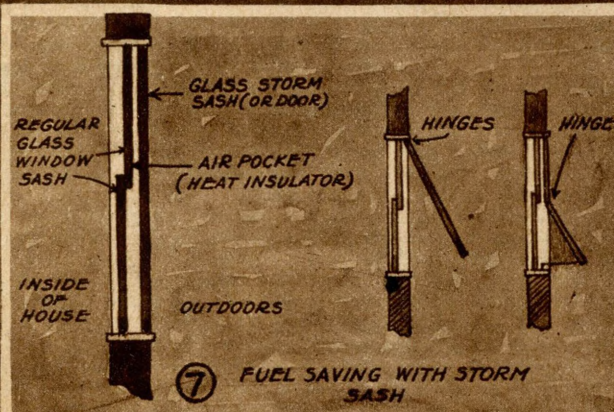

⑦ FUEL SAVING WITH STORM SASH

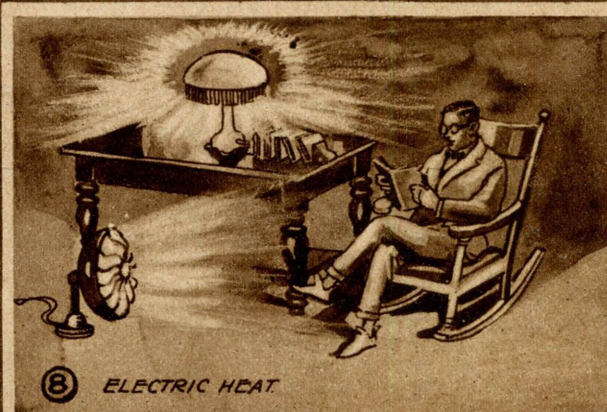

⑧ ELECTRIC HEAT

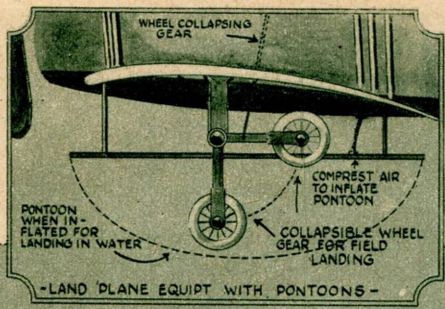

Why Not Flood Low Ground, Such as Swamps and Small Lakes, Wherever Necessary, Thus Providing "Landing Lakes" for Our Aircraft, Instead of Landing Fields, Which Are More Difficult to Find and to Properly Prepare for Such Purposes. The Airplanes of the Future, if Landing Lakes Are Adopted Universally, Can Readily Be Fitted With Wheel Gear as Well as Pontoons.

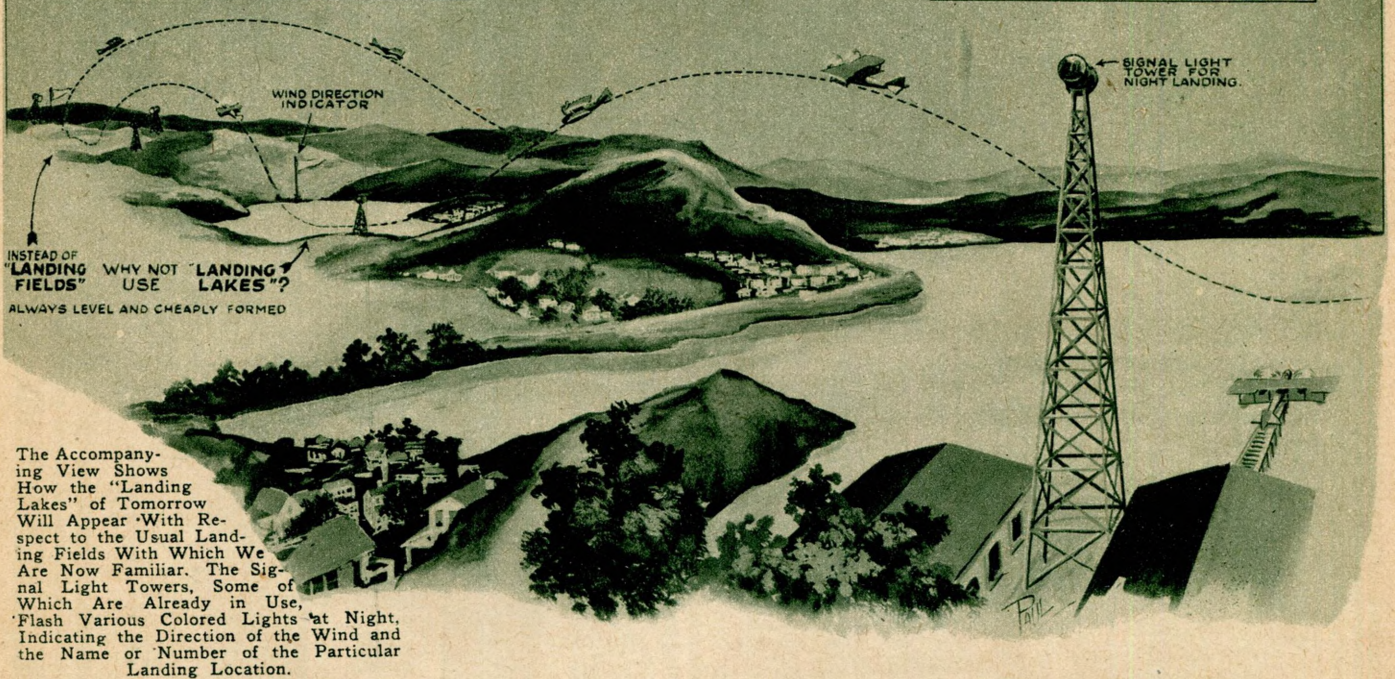
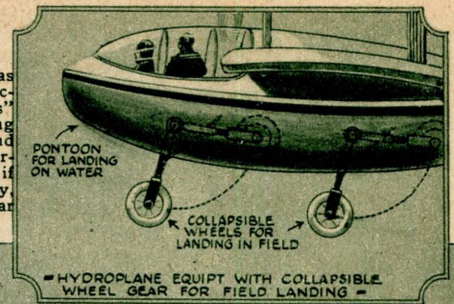

The Accompanying View Shows How the "Landing Lakes" of Tomorrow Will Appear With Respect to the Usual Landing Fields With Which We Are Now Familiar. The Signal Light Towers, Some of Which Are Already in Use, Flash Various Colored Lights at Night, Indicating the Direction of the Wind and the Name or Number of the Particular Landing Location.

"Landing Lakes" for Aircraft

By R. T. CARABIN, Ex-Lieut. A. E. F.

YOU have watched a large airplane soaring over the aviation field in preparation for landing. Perhaps you have seen the great bird come gracefully to the earth without the slightest mishap. But if you talk to the pilot of a large fast plane, he will tell you that once he is in the air there is little to worry him except that he may make the return to earth without damage to himself or his ship.

Let us take for example the little fighting plane of the "SPAD" type—almost a toy to look at—a machine where wing area had been cut down to the lowest limit in obtaining greater speed. To get this little fellow with its ponderous motor into the air requires a large field and a fast run.

Once in the air, however, it has no equal in speed and is as graceful as a swallow, but unlike the swallow it cannot beat back the air with its wings when it desires to land, but must come to earth with almost the same speed it maintained in the air and here is the danger, especially if the ground is not perfectly smooth. But these planes were for war purposes and a few machines more or less smashed in landing, were of little consequence, provided they excelled the enemy in the air.

With the bombing planes it was much the same problem, except that more personnel and equipment were endangered.

These are the general conditions brought about by the war and now that we are on a peace footing we look for improvements in a radical way which will make the air a safe and fast medium to transmit passengers and material from place to place.

Bigger airplanes are being built, and while

we are not in quest of machines of extreme size or speed, we hope for ships which will safely carry fairly large cargoes of personnel to their destination. Just as every other commodity which we now enjoy, started with its small model and then slowly approached, and finally exceeded the practical limit, coming back finally to a size somewhat smaller than the largest constructed, we may look for the same development in aviation.

It is easy to conceive that when aviation is in the same state of development as our marine and rail transportation, the planes will be monstrous indeed compared with those we know today. As we picture these great airships of the future, with their large cargoes of precious human freight, it is evident that landing on the ground would be accompanied by too much hazard to be practical.

We must then look elsewhere for the solution of our landing problems, and turning to water as a possible medium on which to land our giant craft we are promised success, as our present hydroplanes land on the surface of a lake as gracefully as water fowl. But this is only a suggestion of what the future will develop along this line. A better idea of how well water adapts itself to bringing safely to rest great bodies weighing hundreds of tons is gathered by observing a battle-ship in the launching. Slowly it starts its glide, then gathering speed at it goes down the ways, it meets the water and this immense craft is quickly and gently brought to rest—it may be with no other aid than the water itself.

This gives us an idea I believe, of the direction in which we should work. The

problems of overcoming the adhesion of the water in getting the ships into the air again, are problems which our designers will solve as we proceed. Whether the planes will carry pontoons or be equip with all metal wings which will also form the hull for landing; whether they will be fitted with folding landing gear for emergency descents, are all things which will be worked out as time goes on. Here I will only treat on the landing "lakes" of the future, as I see them. And proper landing fields (or will it be lakes?) we must have, in whatever direction we proceed.*

Now when we take into account that the airplane is going to be an exceptionally long distance hauler; and also that three-fourths of the earth is covered with water, it is at once evident that nothing would be lost by adopting water points as the locations where aerial transportation is to begin and end. But we are not limited here. In most localities where men live in any great numbers, there are swamps or low lands which could be flooded as cheaply as dry land could be prepared, even to the extent we require today.

And if the art develops along present lines the landing fields will be required to be larger and smoother every year.

Other advantages which the water covered fields will have are these: Easy to locate, day or night. Absolutely level. No policing required and at length we would find our country dotted with pleasant shallow lakes instead of strange markings on level stretches of valuable land.

*A similar suggestion was made by Mr. H. Gernsback in his recent article, "Airplane of the Future." Sept. issue, page 577.—Editor.)

Great Britain's Mystery Towers

THESE were launched recently at the little English village of Southwick, between Shoreham and Brighton on the Channel coast, two extraordinary "mystery ships" which have long aroused the curiosity of the English public and surely must have given some sleepless nights to the heads of the erstwhile imperial German spy system.

The two mystery ships were laid down during 1918 and have recently undergone completion. These towers, due to their shape, have been nicknamed by the British public the "wedding-cake ships" and not without good reason.

The entire height of each of the two ships is about 200 feet, and they are constructed in such a manner that the concrete bases can be flooded or pumped out at will, thereby raising or lowering the ungainly craft. One of the towers was floated by a flotilla of Portsmouth steam tugs toward Spithead in the English Channel. Only one of the vessels has been sunk in the channel so far, but just where has not been divulged, the British Admiralty being careful not to give out the proposed location of the craft.

The launching took place on September 12th without much ado, as few people had

been informed what was to take place. There was as much secrecy as possible, every workman having been sworn to secrecy. Naturally, in a case like this, where not much is known as to the ultimate purpose or even the *raison d'être* for these ships, not only public curiosity but the curiosity of many scientific men has been aroused. Many speculations have been made as to how these mysterious towers will be used ultimately, and so far one guess is as good as another.

One authority thought that these floating fortresses were to be sent against the Germans to blockade their harbors. They were to be towed by submarines thru the mine fields, and inasmuch as the towers can be submerged considerably below the level of the water, this explanation, fantastic as it seems, deserves some credence. The towers were to be sunk or blown up at the mouth of the German harbor, thus blocking the exit of the submarines.

Still another authority thinks that the device is to be used to raise sunken vessels, but it is not quite apparent why the British Government should go to so much secrecy and spend about five or six million dollars a piece on such towers when there are far better salvaging appliances.

Evidently this was done simply as a blind, so as to hide some of the constructional features of the towers. No doubt this woodwork has been removed or will be removed in due time when the towers are in place.

Our explanation is that these towers are simply submersible fortresses placed at strategical points. The top of the towers would carry a huge gun, a 14 or 16-inch rifle, or even larger if possible. Outside of the armament, i. e., the guns, etc., there would be only sufficient machinery contained within the towers to raise and lower the top of the fortress telescopically, as clearly shown in our illustration. The action would then be as follows:

By means of airplanes the position of enemy battle-ships would be signalled to the towers by radio as shown. Immediately the top of the tower, which heretofore was just awash with the ocean, would begin to rise and within a few minutes would have risen sixty or seventy feet above the surface of the water. Its huge guns would start belching fire almost at once, and the range would be corrected by the airplanes overhead so that few shots would go astray. Note that we are firing from a solid platform and not from a moving vessel. It is

difficult to shoot from one moving vessel to another one, but comparatively simple to score a bull's-eye if we fire from a land station, which these submersible fortresses really are in a sense. During a battle the mystery towers can, if they choose, remain above water, but if attacked by superior force, it becomes possible to submerge within a few minutes, thus offering the enemy no target whatsoever. Even if they do not submerge, the enemy will have difficulty in scoring a hit for the simple reason that these towers only measure about fifty or sixty feet in diameter against a ship's length of 500 to 600 feet.

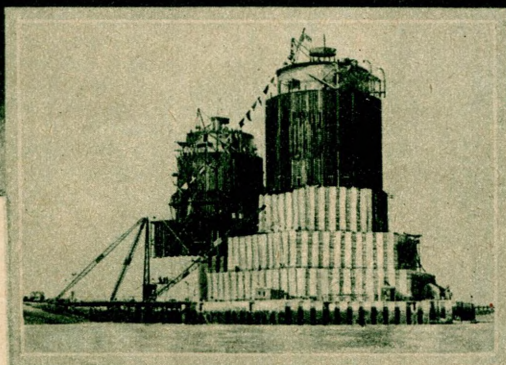
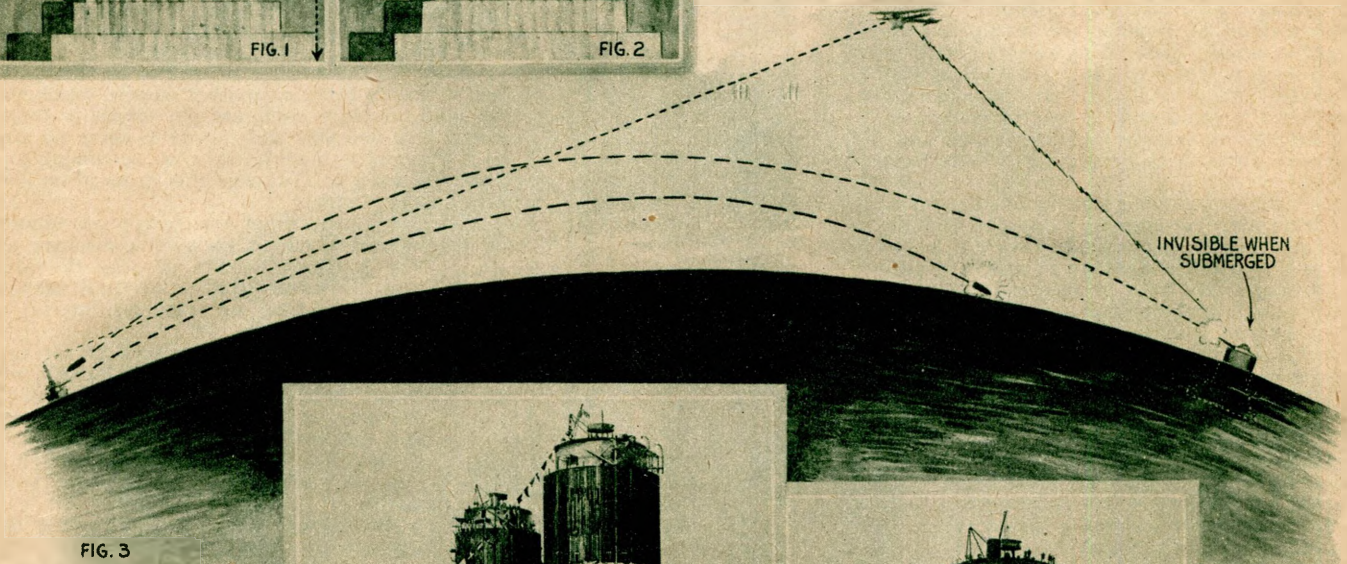
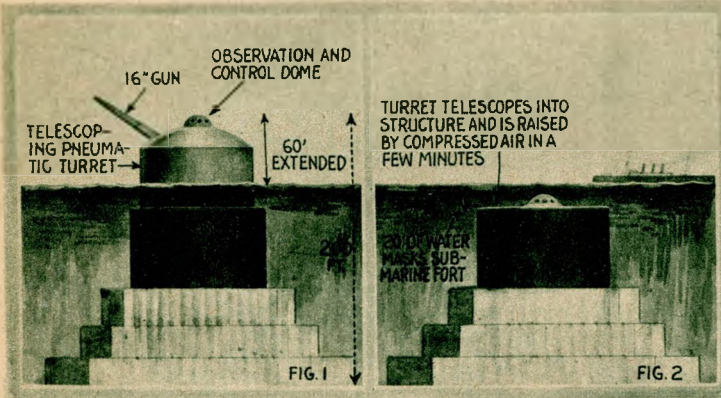
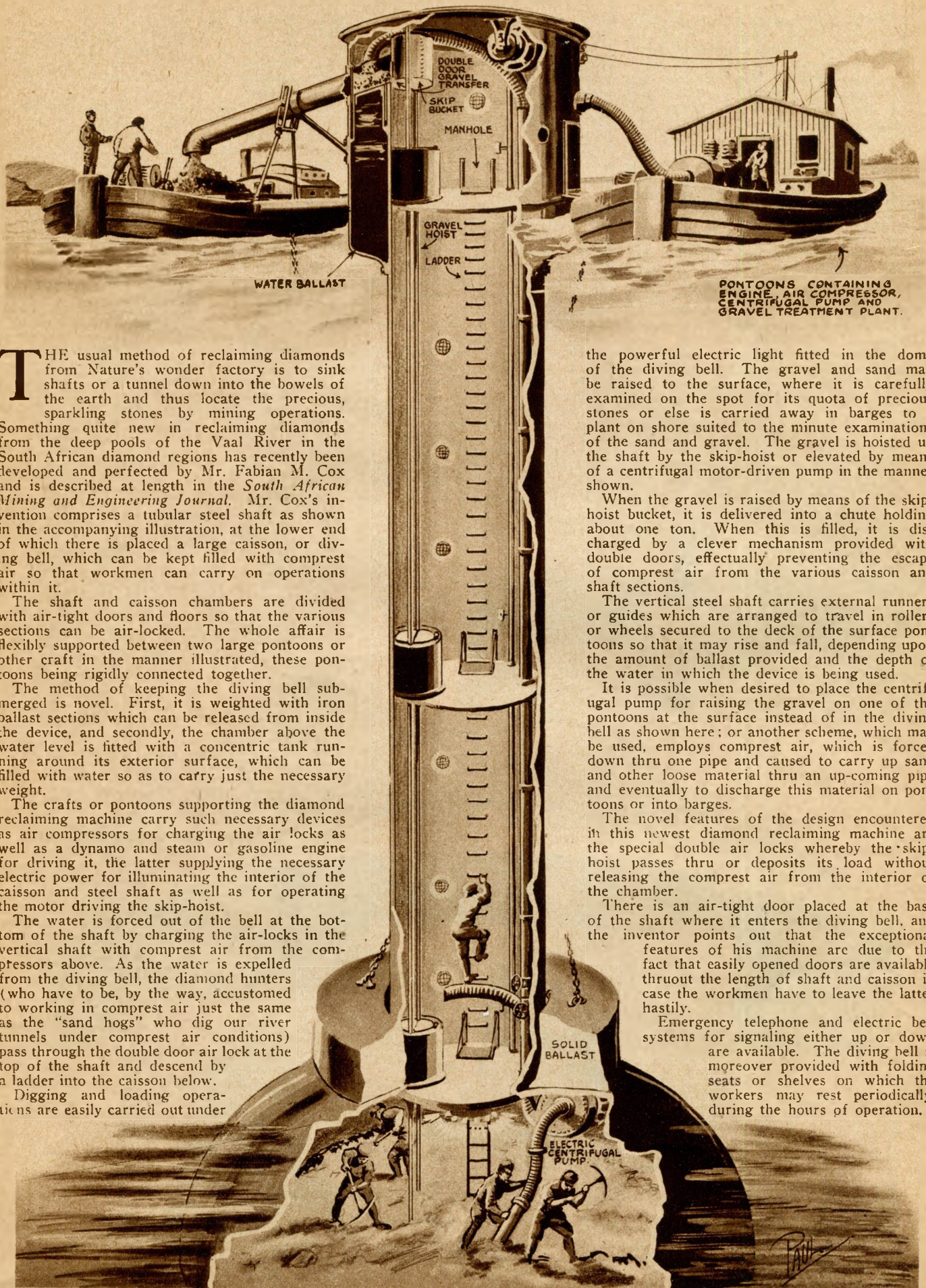

FIG. 3

Fig. 1 and 2 Gives a View How the British Mystery Towers Might Be Used As a Disappearing Sea Fortification. Fig. 3 Shows How They Would Operate in Actual Naval Combat. It Will Be Noted That When Submerged, the Fortresses Are Entirely Invisible and Thus Protected. The Two Lower Views Show the Actual Photographs of the Two Mystery Towers, the Top One Before Launching, and the Bottom One of the Towers Launched and Being Towed to Its Destination Somewhere in the English Channel.

Note Particularly the False Wooden Work Put Up By the British to Camouflage the Towers.

Mining Diamonds With Diving Bell



THE usual method of reclaiming diamonds from Nature's wonder factory is to sink shafts or a tunnel down into the bowels of the earth and thus locate the precious, sparkling stones by mining operations. Something quite new in reclaiming diamonds from the deep pools of the Vaal River in the South African diamond regions has recently been developed and perfected by Mr. Fabian M. Cox and is described at length in the *South African Mining and Engineering Journal*. Mr. Cox's invention comprises a tubular steel shaft as shown in the accompanying illustration, at the lower end of which there is placed a large caisson, or diving bell, which can be kept filled with compressed air so that workmen can carry on operations within it.

The shaft and caisson chambers are divided with air-tight doors and floors so that the various sections can be air-locked. The whole affair is flexibly supported between two large pontoons or other craft in the manner illustrated, these pontoons being rigidly connected together.

The method of keeping the diving bell submerged is novel. First, it is weighted with iron ballast sections which can be released from inside the device, and secondly, the chamber above the water level is fitted with a concentric tank running around its exterior surface, which can be filled with water so as to carry just the necessary weight.

The crafts or pontoons supporting the diamond reclaiming machine carry such necessary devices as air compressors for charging the air locks as well as a dynamo and steam or gasoline engine for driving it, the latter supplying the necessary electric power for illuminating the interior of the caisson and steel shaft as well as for operating the motor driving the skip-hoist.

The water is forced out of the bell at the bottom of the shaft by charging the air-locks in the vertical shaft with compressed air from the compressors above. As the water is expelled from the diving bell, the diamond hunters (who have to be, by the way, accustomed to working in compressed air just the same as the "sand hogs" who dig our river tunnels under compressed air conditions) pass through the double door air lock at the top of the shaft and descend by a ladder into the caisson below.

Digging and loading operations are easily carried out under

the powerful electric light fitted in the dome of the diving bell. The gravel and sand may be raised to the surface, where it is carefully examined on the spot for its quota of precious stones or else is carried away in barges to a plant on shore suited to the minute examinations of the sand and gravel. The gravel is hoisted up the shaft by the skip-hoist or elevated by means of a centrifugal motor-driven pump in the manner shown.

When the gravel is raised by means of the skip-hoist bucket, it is delivered into a chute holding about one ton. When this is filled, it is discharged by a clever mechanism provided with double doors, effectually preventing the escape of compressed air from the various caisson and shaft sections.

The vertical steel shaft carries external runners or guides which are arranged to travel in rollers or wheels secured to the deck of the surface pontoons so that it may rise and fall, depending upon the amount of ballast provided and the depth of the water in which the device is being used.

It is possible when desired to place the centrifugal pump for raising the gravel on one of the pontoons at the surface instead of in the diving bell as shown here; or another scheme, which may be used, employs compressed air, which is forced down thru one pipe and caused to carry up sand and other loose material thru an up-coming pipe and eventually to discharge this material on pontoons or into barges.

The novel features of the design encountered in this newest diamond reclaiming machine are the special double air locks whereby the skip-hoist passes thru or deposits its load without releasing the compressed air from the interior of the chamber.

There is an air-tight door placed at the base of the shaft where it enters the diving bell, and the inventor points out that the exceptional features of his machine are due to the fact that easily opened doors are available thruout the length of shaft and caisson in case the workmen have to leave the latter hastily.

Emergency telephone and electric bell systems for signaling either up or down are available. The diving bell is moreover provided with folding seats or shelves on which the workers may rest periodically, during the hours of operation.

Home Mechanics

Conducted by WILLIAM M. BUTTERFIELD

A COMBINATION PORTABLE AND BRACKET MEDICINE CABINET.

THE medicine cabinet is usually fastened in some more or less convenient location—where one is compelled to journey to it for each dose of medicated compound, an arrangement that under ordinary conditions is quite all right; but there are hurry calls for its aid, when the particular remedy, or the amount of the dose, is known only to the patient who for the time is just able to point it out, perhaps, in the exigencies of the moment. The whole household supply is wanted in the sick-room or place of accident; at such times a portable cabinet will be preferable. In order to meet this desired innovation, a combination portable and bracket cabinet is here shown.

This cabinet consists of a wall frame permanently fastened to the wall with a supporting shelf, a retaining hook and the cabinet proper. The latter, a plain, undecorated case with a carrying handle has shelves and door. The retaining hook is an ordinary clothes-hook, four screw-eyes

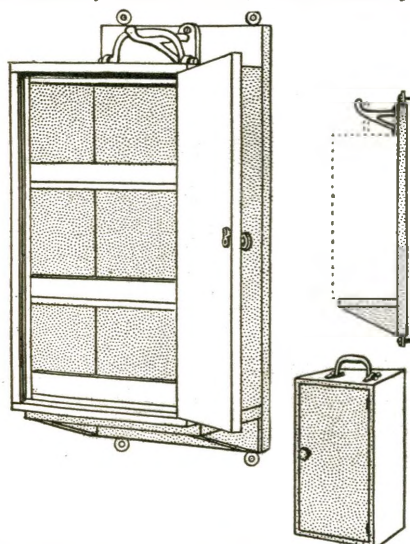

Here is the Very Latest Wrinkle in Home Medicine Cabinets—Arrange the Cabinet to Be Supported on a Bottom Shelf With the Handle Engaging a Hook on the Top So That the Cabinet Can Be Picked Up in an Emergency and Carried Anywhere Desired.

screwed into the frame, form sockets for the wall-screws, the handle, hinges and knob for the door can be obtained at the ten-cent store, and the cabinet and frame are both simple and easily made, thus providing in its entirety, a medicine container that will surely appeal to every "Home Mechanic."

CLOTHES-HANGER BRACKET.

A clothes-hanger bracket that can be taken down or put up at each moving day pilgrimage, is desirable and if it is a good, serviceable bracket—standing all kinds of wear and supporting all sorts of loads—the pilgrim will wish to pack it in his trunk with the rest of his worldly possessions.

The one illustrated is all of this and a little bit more, the more being in the fact that it can be manufactured by anybody, even in a hall bedroom, if no other workshop is handy. The bracket consists of one or more $\frac{5}{8}$ " metal or wooden rods, 11 inches long, made by sawing or filing an ordinary wood or metal curtain rod into the given lengths; four button-head screws $3-16 \times \frac{3}{8}$ inches; and two wooden end pieces $\frac{3}{4}$ inch thick, two inches wide, and the re-

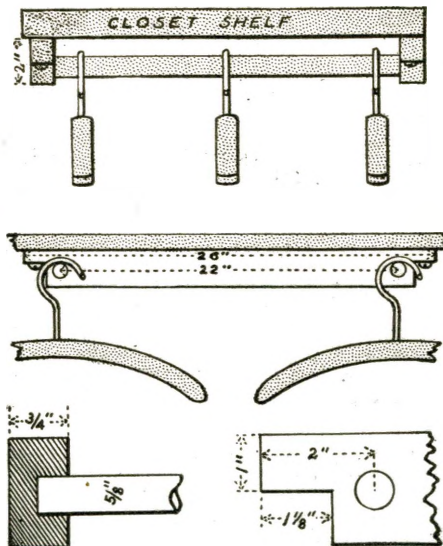

A Simple, Yet Practical Method for Supporting a Large Number of Clothes Hangers, Which the Home Mechanic Can Build at Practically No Cost.

quired length—say six inches for one rod, 26 inches for two rods, and 37 inches for three rods.

Most closet shelves are 12 inches wide so that we say the rods may be made 11 inches long, but if the shelf is narrower, the rods must be one inch shorter than its width whatever it may be. The holes for the rods are bored 22 inches apart, two inches from the ends and in the center of the two inch sides of the end pieces; using an 11-16 bit and going only half way thru the wood. The screw holes are bored with a 3-16 inch bit, and all the way thru the wood, the jogs being sawed first to measurements given.

HANDY BREAD OR MEAT BOARD.

A bread or meat board with the desirable end-of-the-wood-surface found on the butchers' block is always wanted round the kitchen, yet one cannot always have this kind of a board for the simple reason that there is no such board on the market. The one here illustrated is of this kind, but to have it, one must make it—a task not at all difficult providing the part under the

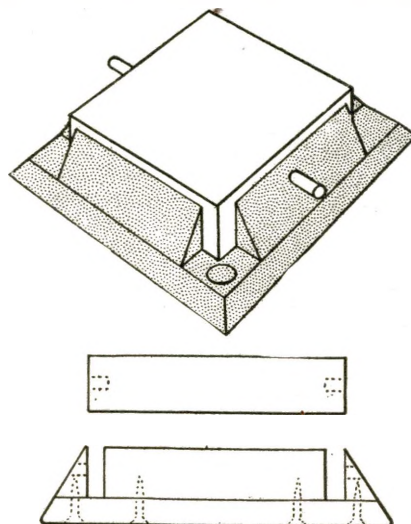

This Invaluable Meat or Bread Board for the Home Kitchen or Pantry Is Constructed From a Piece of Hard Wood Such as Maple, and Possesses the Advantage That It Can Be Thoroughly Cleaned, and Is Withal Light in Weight.

knife can be obtained. This is not altogether impossible, for we give a view of an actual part, now in use—one purchased at a shop providing such blocks to wood-engravers. It is of the cheaper grade of block used for large poster work, about $\frac{7}{8}$ of an inch thick and 8 inches square—the area could have been anything up to 30 inches if wanted. The wood is usually maple—a very hard wood. Such pieces are sold by the square inch, costing about two dollars for the eight-inch square, and are worth that for the purpose, as the wood is practically indestructible.

The holder is made as shown, using brass screws and wooden pins, care being taken to have the holes both in the base and block bored so that each pin will be tight in the frame and loose in the block, the object of the pins being merely to keep the block from falling out when the board is hung up. The holes should be placed so that the block can be put in the frame and secured either side up, or in any direction (four holes in the block and two in the frame), thus insuring against warping.

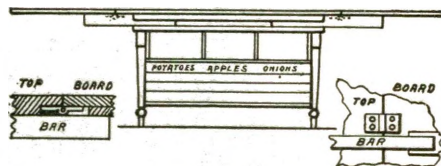

Here We Have a Kitchen Cabinet Built Right Into the Work Table With Compartments for Potatoes, Apples and Onions—a Very Useful Wrinkle, Indeed.

A CABINET FOR THE KITCHEN TABLE.

Take a table of the ordinary kitchen variety (which at one time was thought expensive at a dollar), as the foundation for this space-saving device.

First attach two wing extensions, one at either end, using large size bread-boards, trimmed to the width of the table top, as the extended parts—this makes the table double its original capacity—the ends being attached with hinges and let down in the usual way; sliding bars, fastened to the table with stationary bars as shown hold the ends when in use. A small drawing shows the method used if the table top and board extensions are of different thicknesses as will very likely be the case when the common commercial ready-made boards are used.

Next make a cabinet to hold potatoes, apples and onions. This consists of any convenient box, fastened to the table, and divided into compartments. We show one made wedge-shape, which will thus cause the contents of the compartments to always lie at the front within easy reach. It is made of narrow boards nailed to extended corner-pieces that are finally fastened to the table as shown. The partition boards are also set at an angle, chiefly for the purpose of saving lumber.

The Amateur Magician

By JOSEPH H. KRAUS

The Coin Wand

PROFESSOR HARGRAVE had not yet recovered from the effects of his long vacation, when I pounced in on him just prior to a terrific thunderstorm which a short time later enshrouded the entire villa in a veil of darkness, except at the frequent intervals in which livid lightning flashes illuminated the scene, each flash being accompanied by an incessant roar a second or so later, proving that the storm was very close. After answering each other's questions for half an hour or so, the storm abated sufficiently to allow us to proceed with the main mission of my errand.

Hargrave answered my question with, "Do you know, old timer, when I go away on a vacation I take a complete rest and do not attempt to ferret out any further mys-

millions of particles of this silver substance in a pure state, exactly identical with the coin content!! If all of this silver which is annually rubbed off coins could be collected, we would be quite wealthy, but meanwhile we can collect all that is floating around us."

So saying he swept his wand thru the air and there—lo and behold—was a coin right at the end of that instrument! With a quick shake the coin could be heard clattering into the hat, to meet its mate, and before I knew it he had collected 12 to 14 coins.

"You see if it weren't for the noise made by the coins falling into the hat you could scarcely hear them." After assuring me

cut in the manner shown, so that an obtuse angle on the cut side is formed. These are hinged as near to the end of the wand as possible and over-lap each other. The little spring holds them in a closed position so that they cannot be seen unless the wand is in operating condition. The springs are mounted as you can readily see by this rough sketch enabling this position to be maintained. The wand itself is 1/2 inch in diameter, which is amply sufficient to conceal the half dollar. At the same time when this opens, the coin projects on both sides, giving rise to the illusion that the coin is being held at the end of the wand in some manner not readily ascertained, which in itself constitutes quite a puzzle. In order to enable the opening of the coin we have a solenoid (electro-magnet) em-

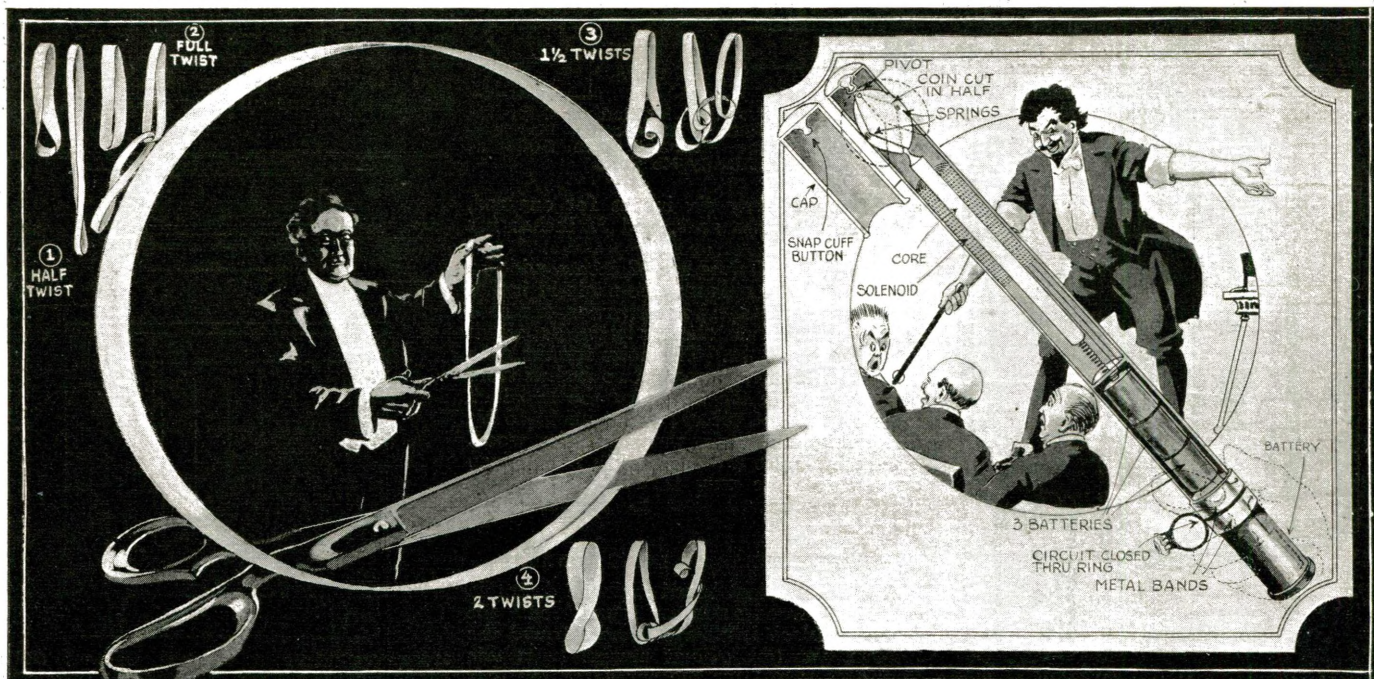

Above We See the Paper Cutting Trick Wherein, Try as Hard as You Will, by Cutting a Band of Paper in Half, Longitudinally, You Cannot Help But Make Two Bands. Yet When You Know the Art of the Trick, by Cutting the Band in the Same Manner, You Can Make One Continuous Band or a Linked Band, or Even One With Several Knots.

Here is a Diagram of a Magic Coin Wand Which Foils Detection. It is Electrically Controlled. Note How the Ring Makes Contact Between the Two Metallic Bands on the Handle Closing the Circuit, and in This Way Causes the Current to Flow Thru the Solenoid, the Core of Which Separates Two Split Coins, Making it Appear as Tho the Coin Was Caught in Mid Air.

teries. I have a little stunt here, however, which will please your readers, particularly in view of the fact that it is simply made and employs, as do my other tricks, electricity in the very simplest manner. Let me have your hat—no, this will never do: I thought perhaps that you might have secreted about you one of those stove-pipe affairs. Wait a second until I procure one of mine."

A few moments later he was back in the room with a high silk hat in one hand and a little black stick about 15 inches long in the other, which he called his *Coin Wand*. Proceeding to demonstrate the effectiveness of his little instrument he said, "A very simple method of making counterfeit, as you undoubtedly know, is to pass a stick of this nature thru the air and collect the particles of silver floating in the atmosphere into one unit mass, forming them into a coin at the same time. You see each time that we handle a silver coin we rub off some of the silver. That accounts for some coins becoming thin from wear. This silver of course does not remain on our fingers but is brushed off, and due to the air circulation we soon have floating about

that the coins were not counterfeit, I requested to examine the wand which he did not hesitate to let me do. There was nothing unusual in its construction. A black metal band fitted on one end, and two parallel nickel-plated bands on the other. Aside from that it was quite a solid construction with nothing to indicate the way in which the coins came or were even suspended around the end of the wand.

After toying with me a little longer he gave me the secret of one of the cleverest little devices which he had ever originated. Saying this he took the wand from my hands with: "You're not as green about magic as I thought you were,—you're worse." Pulling at the metal cap at one end he removed it, and then the trick could be readily seen, for a slot in each side of the wand concealed half of a coin. Of course I desired more details of constructions which with Professor Hargrave's frank and willing manner to help, were not difficult to obtain.

Taking the wand apart he showed me its construction, explaining it in the following manner: "The original magicians' coins, as you know, resemble half dollars which are

bodied in the wand. This solenoid has a soft iron core three inches long, the core coming to a flat point at one end. This core moves within the solenoid coil which is 2 1/2 inches long and wound very compactly with No. 28 wire, or wire which can be taken from an old bell, until a total thickness of 7/16ths of an inch is eventually realized. This makes a very snug fit into the metal wand. A spring is attached to the core of the solenoid to draw it back so that it will not interfere in any way with the proper closing of the coin whenever the current is shut off. In the other part of the wand is the battery, simply removed by this end cap which must be pulled quite hard in order to remove the same. As you will note, two springs hold the cap in place. No one on examining a wand attempts to pull it apart or handle it roughly, particularly if cautioned beforehand. Therefore, the closure of this end is quite effective, and as it can be turned all around if one tries to unscrew the end, it is never thought to be 'part of the game.' The positive pole of the battery goes directly to the solenoid and the negative is past out thru the wand

(Continued on page 908)

Practical Chemical Experiments

By PROF. FLOYD L. DARROW

Some Metals and Their Properties

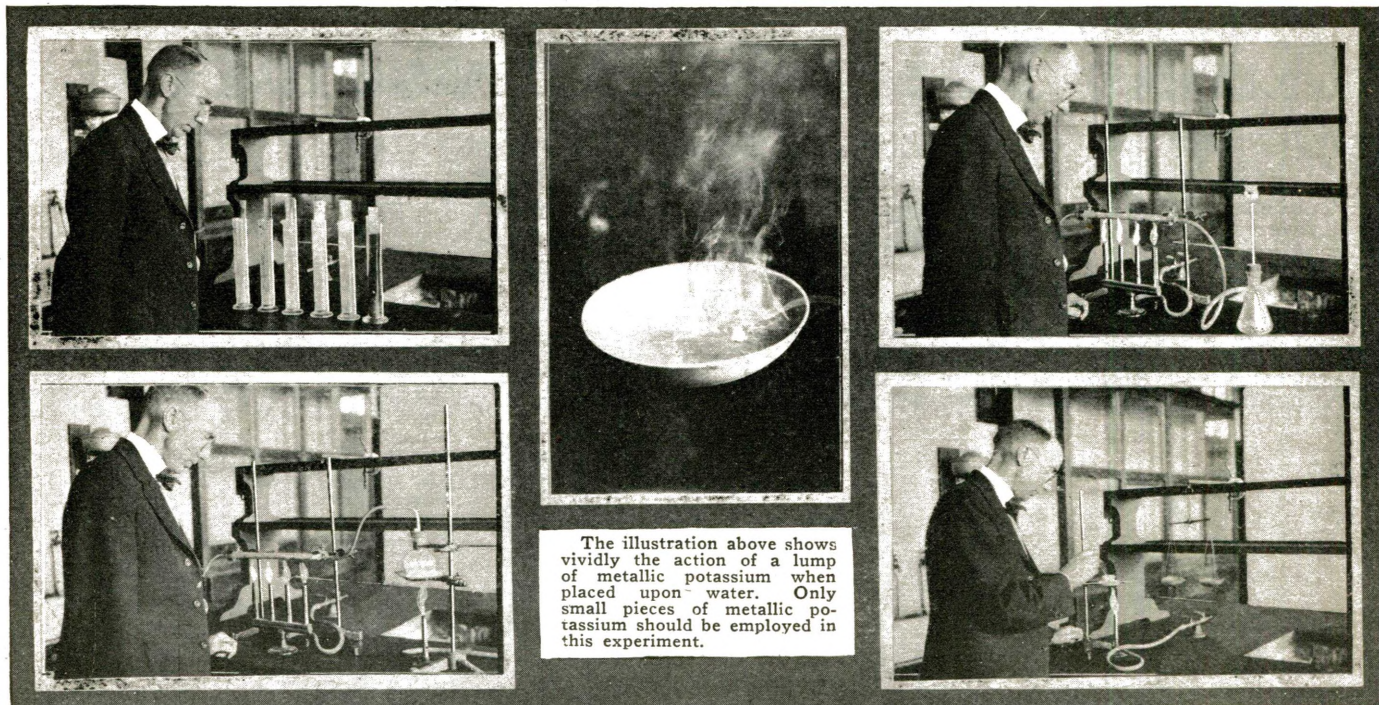

The illustration above shows vividly the action of a lump of metallic potassium when placed upon water. Only small pieces of metallic potassium should be employed in this experiment.

Above:—Displacing metals from their solutions by the action of zinc and copper.
Below:—Oxidizing heated copper by passing a stream of oxygen over it.

Above:—Reducing hot copper oxid by passing a stream of hydrogen over it.
Below:—Determining the weight change on heating a metal in the air.

FROM prehistoric days to the present moment metals and metal-working have been supremely important in the affairs of men. Indeed, the progress of the race may be measured by its growing proficiency in the working of metallic ores and particularly in the metallurgy of iron and steel. At what time in the dim and distant past primitive man thru his mastery of fire past to a knowledge of metals and their wonderful properties, so indispensable to his conquest of the earth, no record discloses. Certain it is that for long centuries before the Christian Era, metal working was a highly perfected art. Doubtless gold and copper, which occur in the free state, were the first metals known to man. Tin was also one of the early metals. History tells us that copper and tin in their alloyed form of bronze characterized a long period in which other metals were little known. Tools found

in ancient ruins and their easy metallurgy show this to be true. And yet iron has been found in the pyramids of Egypt built centuries before Christ. Much evidence, too, points to a knowledge of iron by the Assyrians, Chaldeans and Babylonians, who occupied the plains of Mesopotamia at a much earlier period. But whatever the truth, the mastery of metals and their skillful adaptation to the varied arts of peace and war have spelled power and dominion—dominion at first over the material elements of nature, followed by the military and political sway of empire.

But it was not the utility of metals that first arrested the attention of savage men. As some cave man raked over the dying embers of his camp fire, he doubtless discovered globules of bright metal. This happy accident at first aroused only his curiosity and excited his superstition. But the repetition of the discovery led him to

investigate and in time the high lustre and properties of toughness, hardness and malleability must have demonstrated the superiority of these new substances to wood, bone and stone for implements of hunting and warfare.

Some Properties of Metals: The properties of all elements are divided into two classes—physical and chemical. From the physical standpoint metals, in the pure state, have a high lustre and are good conductors of heat and electricity. Many of them are tough and malleable. Chemically, metals vary from those of great activity, as sodium and potassium, to gold and platinum which are little affected by some of the strongest reagents. Some metals readily liberate hydrogen from acids while others do not.

Heating Metals in the Air: One of the most marked differences in metals is to be

(Continued on page 913)

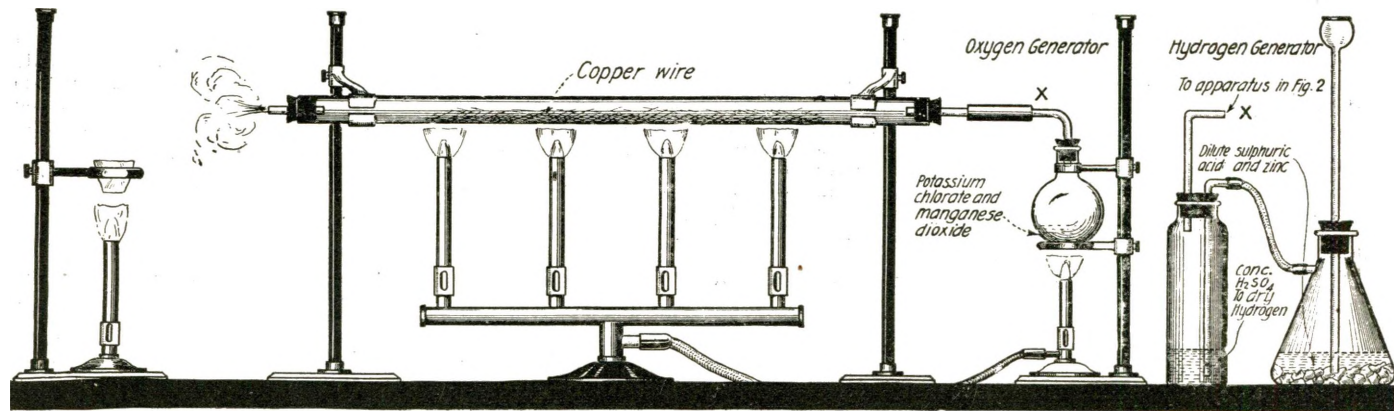

Fig. 1
Heating a Metal in the Air, the Metal Being Placed in a Crucible.

Fig. 2
Apparatus Set Up for Performing the Oxidation of Copper Experiment.

Fig. 3
Reduction of Copper Oxide to Metallic Copper by Means of Hydrogen.



THE CONSTRUCTOR

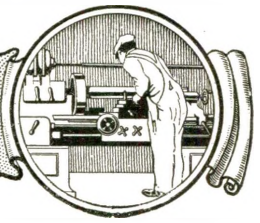

Xmas Electric Amusements

EVERY Yuletide season those of us who possess electrical ideas endeavor to work up something new for the amusement of the children, both young and old. The layman usually has trouble in deciding upon the connections of electric lights for the Christmas tree, and Fig. 1 shows the principal and predominating forms of circuit in use with the small decorative lighting festoons.

There are two main subdivisions of the forms of circuit which can be used for tree lighting, namely, *series* and *parallel* circuits.

How to Connect Xmas Tree Lights; Also How to Construct Electric Carousel, Scenic Railway and Church

The voltage of each lamp in this case is determined by dividing the 110 volts by the number of lamps. The 14-volt lamp is used because it is a standard type. In some

drives a low-voltage dynamo, say one rated to give 4 to 8 amperes at 6 to 8 volts.

An Electrically Lighted Church for a Miniature Christmas Village

One of the most common decorations used by the Christmas tree decorator is of course the *toy electric railway*. This is operated either from dry or storage batteries or else from the 110-volt A.C. or D.C. lighting circuit, thru the agency of a step-down transformer or rheostat. As everyone is familiar with the toy electric railway nothing more will be said here with reference to it as complete instructions are available from the makers or the stores selling these railways.

Last year we constructed a very pretty little church, like the one shown at Fig. 2, which was made out of nothing but cardboard and a piece of wood or two, together with the electric lights of course and any other details which the builder may wish to work out.

The dimensions of the small cardboard church shown were approximately 14 inches long by 8 inches wide by 14 inches high. The sides of the building were made of fairly strong cardboard, the windows being laid out and measured off with a rule so as to be evenly spaced, and the complete openings for the windows were cut out with a sharp knife, placing the cardboard on a piece of soft board while doing this.

In this case the windows were covered on the interior with a piece of light pink tissue paper, but blue or any other color may be used, and by using two or three different colors placed across the windows in strips a multi-colored effect will be produced similar to the leaded glass windows of a church. A similar effect can be obtained by using several variously colored electric light bulbs inside the building, and, for those who are ambitious to make the church particularly attractive, these lights can be winked on and off by means of a flasher constructed from a toy motor or an old clock movement rigged up with a commutator and brush as shown in one of the illustrations.

The church as shown may be made with an ordinary steeple on it, inside of which an incandescent lamp of the same size used in illuminating the Christmas tree can be

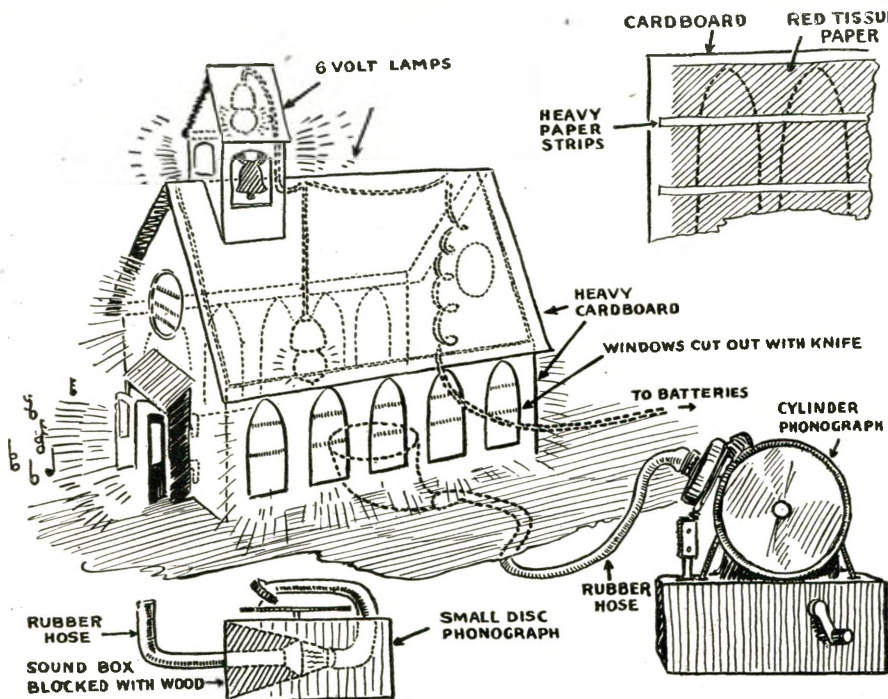

Fig. 2.—With Very Little Labor, This Pretty Model Church Can Be Constructed from Cardboard and a Few Pieces of Wood, Together With a Battery Lamp or Two With the Necessary Receptacles and Wire. Music May Be Introduced from a Phonograph in the Manner Shown.

In the series circuit, as shown in Fig. 1, the current travels thru one lamp, then passes on and thru the second lamp, etc. It is evident in this case that if one of the lamps or sockets becomes defective, the whole series will be affected until a new lamp or socket is substituted.

In the parallel circuit each lamp is connected across two wires of the circuit, all in parallel with each other, like the rungs of a ladder. With the parallel-fed circuit, one lamp becoming defective will not interfere with the lighting of the others. For low-voltage dynamos and battery-current supply, parallel lamp circuits for Christmas tree circuits are invariably used, the full voltage required for the whole circuit in this case being that required for one lamp with a slight excess in the circuit conductors, and the current in amperes necessary is computed by multiplying that required for one lamp by the number of lamps connected in parallel.

For 110-volt A.C. or D.C. circuits the *series* lamp festoons are invariably used. Eight 14-volt lamps connected in series are equivalent to 112 volts, and this is a common arrangement of the 110-volt festoon.

cases those who own an automobile remove the storage battery, or else run wires from it into the house and operate the lights on the Christmas tree from it. In other cases a small water turbine fitted to a spigot

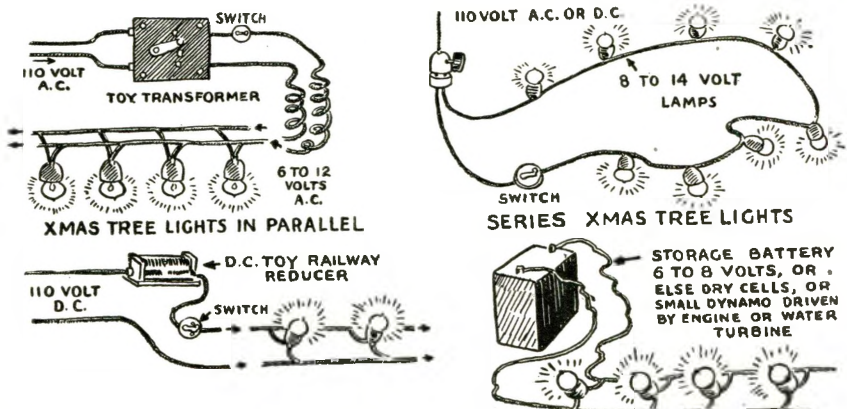

Fig. 1.—Above Shows Series and Parallel Circuit Connections for Christmas Tree Lights; Low-Voltage Lamps for Battery or Other Low-Voltage Current Supply Are Connected in Parallel. Lamps Are Connected in Series to Balance a 110-Volt Circuit.

placed and the outline of a bell can be painted on the tissue paper covering the windows of the steeple. If desired, of course the steeple may be fitted with a pointed spire made of wood or cardboard several inches in height. The church windows may be left plain without any cross-rails, but the cross-rails are easily formed by cutting several strips of heavy paper about 1/8-inch wide and gluing these across the windows over the top of the tissue paper as shown in detail at Fig. 2.

The rest of the details can be easily worked out by the builder as everyone will probably want to make some variations in the style of the building for himself. The outside of the church, particularly the front, may have its appearance or effect greatly enhanced by the application of water color paints, and in the writer's design the front door was boldly painted on in good strong water colors. By using white tissue paper for covering the windows a clever leaded-glass effect may be imitated by the use of water color paints. If the four sides of the church have been completed, they may be tacked to a base of 1/2-inch or 1-inch board, which is cut to the right size of course, and the cardboard can be held in place with a few small wire clips or pins.

A few small pieces of cotton can be laid out around the church and over the top, a little artificial snow (powdered mica) thrown over the building and also some cotton. In making these Christmas tree decorations, while constructing the village scene and in arranging the base of the tree we covered up the intervening space between buildings, railways, etc., with a piece of cloth. This may be of any color desired, but a white sheet is about as good as anything. This is then covered with pieces of cotton here and there, and then the whole scene sprinkled with some artificial snow.

In the illustration showing details of the miniature church it will be seen how a small phonograph which may be placed in a sound-proof box fitted with suitable cover is used to provide music and instead of being allowed to come from the phonograph directly, it is conducted thru a rubber tube passing thru a hole in the

Fig. 3.—For Those Who Are Really Ambitious to Have Something New in an Electrical Christmas Display the Idea Shown Below Will Prove of Interest. It is a Miniature "Merry-Go-Round,"

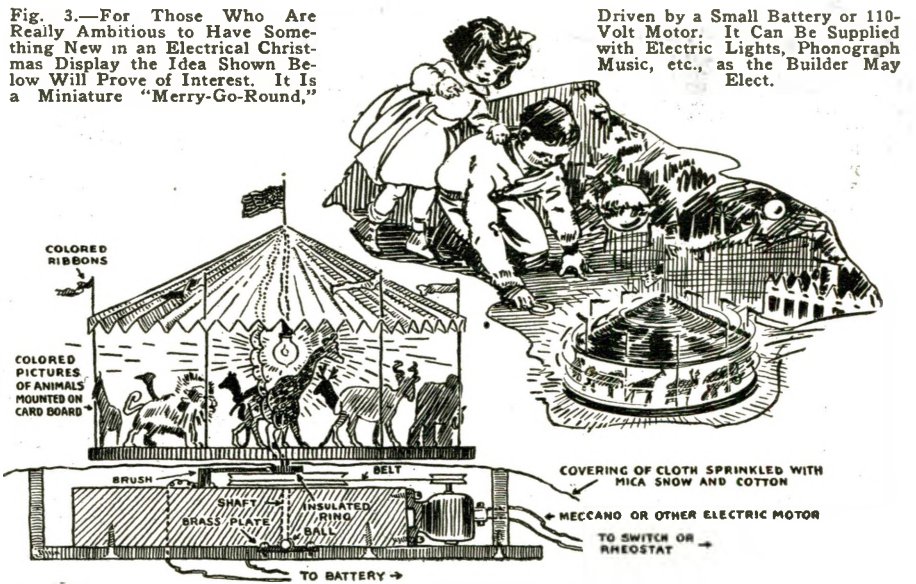

Driven by a Small Battery or 110-Volt Motor. It Can Be Supplied with Electric Lights, Phonograph Music, etc., as the Builder May Elect.

wooden base of the church. In this way a suitable switch placed on the exterior the music will seem to come from inside the church.

If you possess a toy music box which toy

An Electric Carousel

Something new for the home Christmas tree scenic artists is shown at Fig. 3—a real, live, electric carousel. With a little ingenuity and patience this can be made quite a realistic affair and one that will be enjoyed by everyone from little baby to grandad.

One of the first things which will make this a howling success will be to endeavor to fit either behind the carousel or on it, if possible, a small music box or toy organ; or again, a small phonograph (under the display) and rig this up so as to be operated when desired in connection with the revolving carousel.

Little need be said in connection with the building of the carousel, except of course it should not be made too heavy or clumsy for the size of motor one has at hand. The motor should be mounted vertically if it will run well in that position; but if not, it can be placed with its shaft in a horizontal position and the belt simply given a one-quarter twist as it passes around the pulley groove in the base of the carousel.

A great part of the friction on the steel shaft supporting the carousel can be mitigated by placing it upon a large ball-bearing. A brass or iron plate should be under the hole, which is drilled in a piece of plank or board, thus forming the bed of the display, on which the ball may rest. The hole supporting the merry-go-round shaft may be a suitable size hole drilled into the wood base supporting the affair. It should be liberally lubricated with vaseline and a little oil applied now and then.

The outfit may or may not be fitted with an electric light, as the builder may elect; if an electric battery light is fitted inside the carousel, it can be supplied with current thru an insulated brush and a metal ring mounted on a piece of wood or fiber fastened to the shaft and rotating with it, as indicated, the other side of the circuit being formed thru the shaft and bearing of the turn-table.

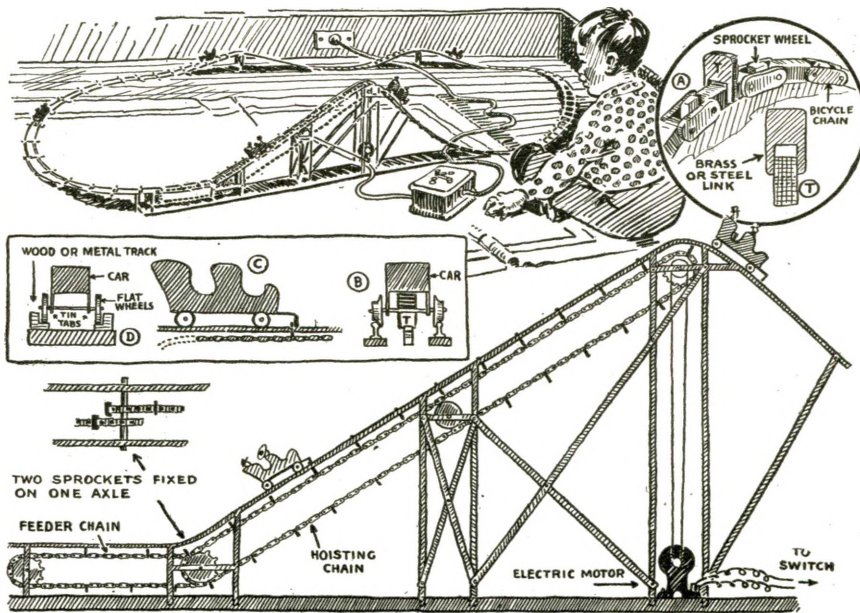

And Here We Have a Toy Scenic Railway Which Can Be Built by Anyone Handy with Tools and With a Fair Idea of Mechanics. Instead of the Bicycle Chain a Flat Belt May Be Used With Studs Secured to It for Hauling the Cars Up the Grade. Fig. 4.

shops sell for a small sum, this can be rigged up with an electric motor and played whenever desired inside the church by

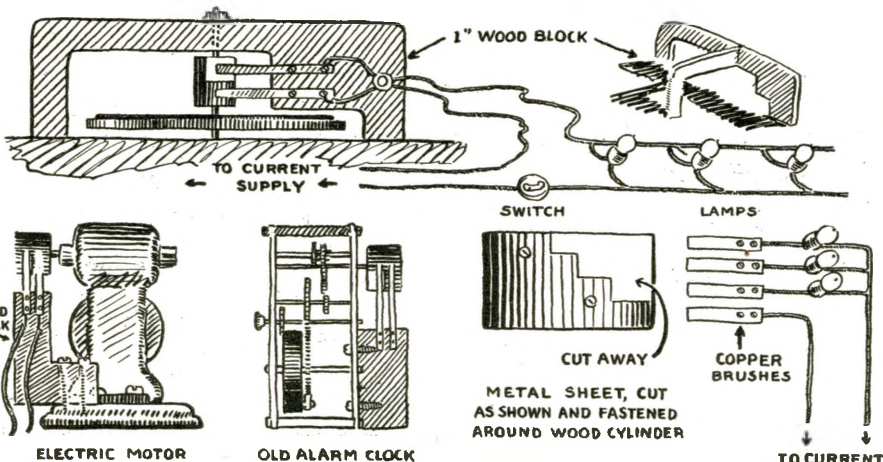

An Interrupter or Flasher for Christmas Tree Lights May Be Constructed in Several Ways, as Here Shown. It May Comprise a Segmental Drum, Rotated by a Phonograph Motor, by a Battery Motor, or Again by an Old Alarm Clock. Fig. 5.

(Continued on page 904)

Telephone Ringing Relay

I give herewith a drawing of a very good telephone relay which I have found to work successfully. The magnets A are of 1,250 ohms which are fastened to a slate (fiber O.K.) base. The rod B is eight inches long and is made of iron and fiber as shown in

drawing. The cups D, D, are made of cast iron or steel and are filled with mercury. The screws E, E, are of iron and are screwed thru the rod into the mercury cups. The piece of brass, O, is put in the fiber as shown in Fig. 2 so as to close the circuit in the two screws E, E. The pivot F is made of brass as shown in Fig. 5. The stop post, h, is a piece of brass with a screw that can be adjusted so as to stop the length of the stroke of the rod.

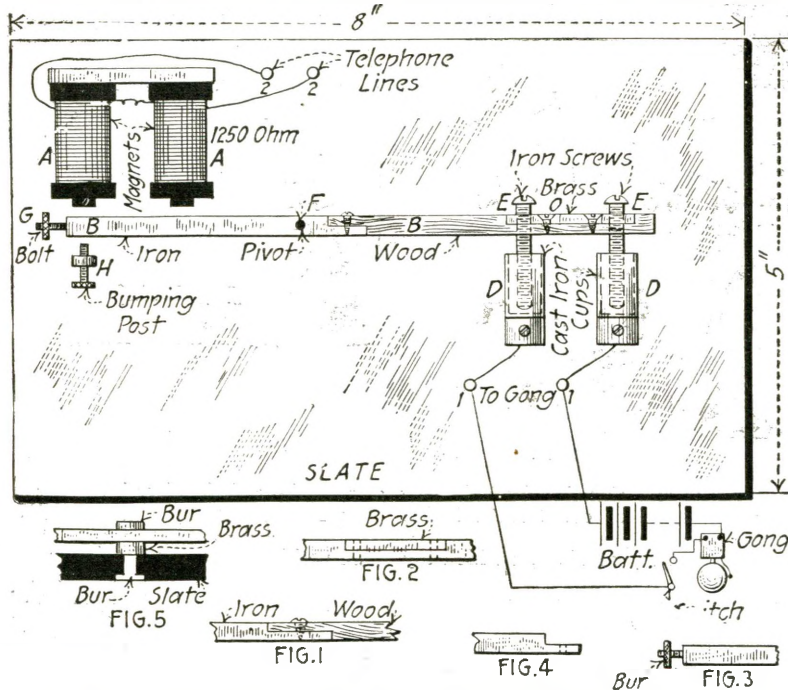

On the end of the iron part of the rod make some threads for a large burr as shown in Fig. 3, to be used for a weight-adjusting screw or counter-balance. The figures 2, 2, go to the telephone line, figures 1, 1, go to the bell or gong. Fig. 1 shows how the iron and fiber are fastened together. Fig. 4 shows how the cast iron cups are made. When the current enters the magnets, A, it pulls the rod B, which dips the screws E, E, into the mercury and closes the gong battery circuit.

It will be found best to make a small metal or wooden cover to fit over the relay so as to keep it free from dust, particularly on account of the mercury switch. The electro-magnets used for operating this relay can often be procured from a discarded polarized telephone ringer, and it will save you the trouble of building the iron frame and cores and the winding of the magnets. In checking up the resistance of the magnet coils, this may be done with the aid of a Wheatstone bridge, or else if you have a voltmeter and ammeter handy, you can measure the resistance.

Contributed by SHERMAN HEALD.

Frequently it is desired to ring a good-sized extension bell whenever your telephone signal rings. The best way to do this is to use a telephone relay, which closes the local battery and bell circuit, and instructions for building such a relay are illustrated herewith.

Automatic Indicator for Storage Cells

Having use for an accurate, inexpensive and entirely automatic device to indicate the chemical and electrical condition of the storage cell, I constructed the following device.

A glass tube (F) see drawing, just long enough to rest on bottom of glass jar of cell (B) and allow top (H) of cell to fit tightly, was placed inside of the storage cell vertically between the plates (D) and jar. Contained in the tube is a small glass tube, having one end closed in a gas flame, the other end being closed by a paraffined cork of such a diameter that it is free to move up and down in the containing cylinder.

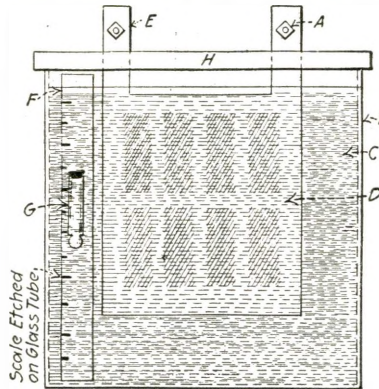

The inner tube is regulated by placing lead filings (or small buck shot) inside so that it rises or sinks according to the strength of the electrolyte and whether the cell is charged or not. To make the device more accurate a scale may be scratched with a glass cutter, carborundum, a diamond, or else etched with hydrofluorspar on the outer tube.

In concluding I would like to add that I have used the device in my laboratory with entire success and have found that when the battery consists of a number of similar cells only one of these devices is needed.

Contributed by WITOLD DE ZYCHLINSKI.

Experimental Arc-Light

I herewith present a description and drawing of an experimental arc-light which I have constructed with my Meccano outfit. It is very simple and works nicely.

The carbons are held in place by double-bent strips (A) and nuts and bolts (B). The movable carbon is on a car or carriage (C) which runs on a track (D) 2½ inches wide and 12½ inches long. It is moved by chain (E) which passes over wheel (F) and back to gear box (G) and is moved by crank handle (H). By moving the handle the carbon is moved slowly and enables you to keep the light steady. On the crank-handle is a brake or pawl (I).

The drawing shows the gears clearly. The stationary carbon is raised to the level of the movable carbon by angle-bracket (J). The wires are connected to the frames by binding posts (K) and are separated by space (L).

I have had good success with this light and run it on my toy transformer, at twenty-

six volts. When finished I screwed it on a board. I am a subscriber to your magazine, which I like very much, and trust you will publish it in your magazine for the benefit

of other interested electrical experimenters. I will send you a photograph of my model as soon as I get it printed and developed.

Contributed by EDGAR KROEHLE.

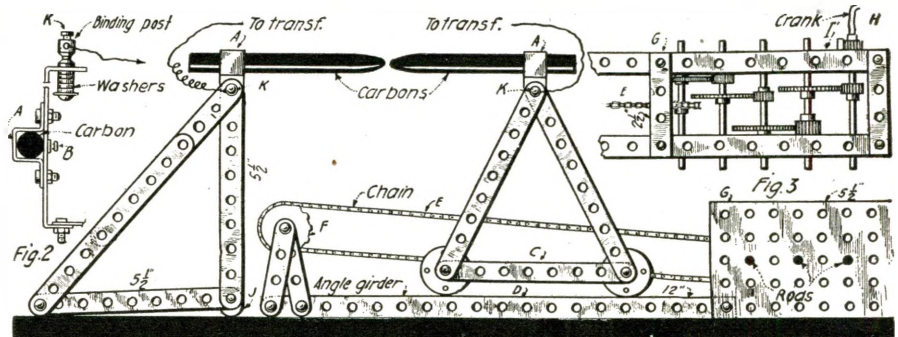

Fig 1
A Clever Experimental Arc Light Built From Meccano Toy Parts. The Arc Light Was Successfully Operated From a Toy Transformer on 26 Volts.

Electric Arc Welding Electrode

By E. W. DONALDSON

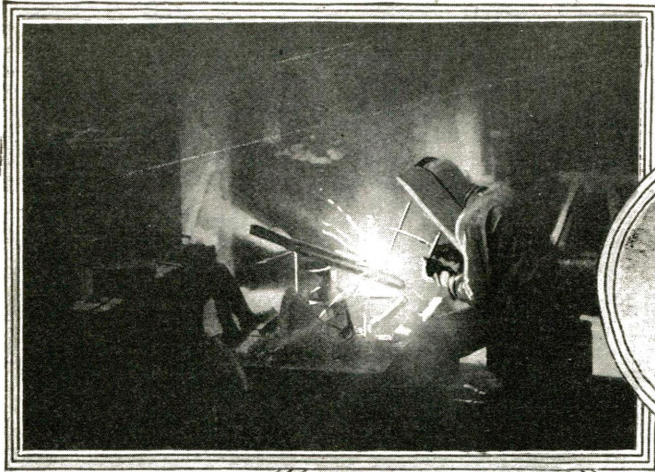
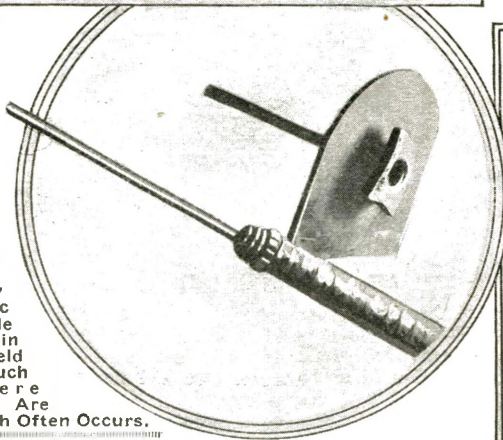
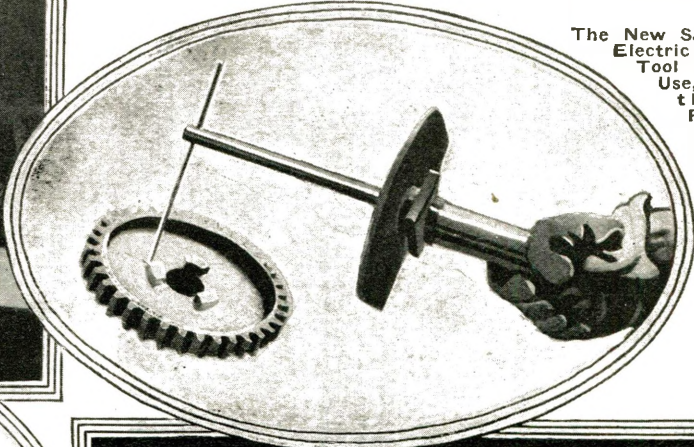

Photo Above Shows Operative Electrically Welding Steel Parts Together at a Temperature of 3,500 Degrees Centigrade, Equivalent to That of the Oxy-Acetylene Flame.

This Shows the Parts of the New Electric Arc Welding Electrode Here Described in Detail. The Shield May Be Made Much Larger Where Heavy Currents Are to Be Used, Which Often Occurs.



be used as the clamp a hollow core is attached to the end of the engages regardless of welder, allowing the welding rod to pass the size of the rod. thru the core. The coil will be a short



The New Safety Grip Electric Welding Tool in Actual Use, Showing the Fine Rigidity and Balance of the Tool.

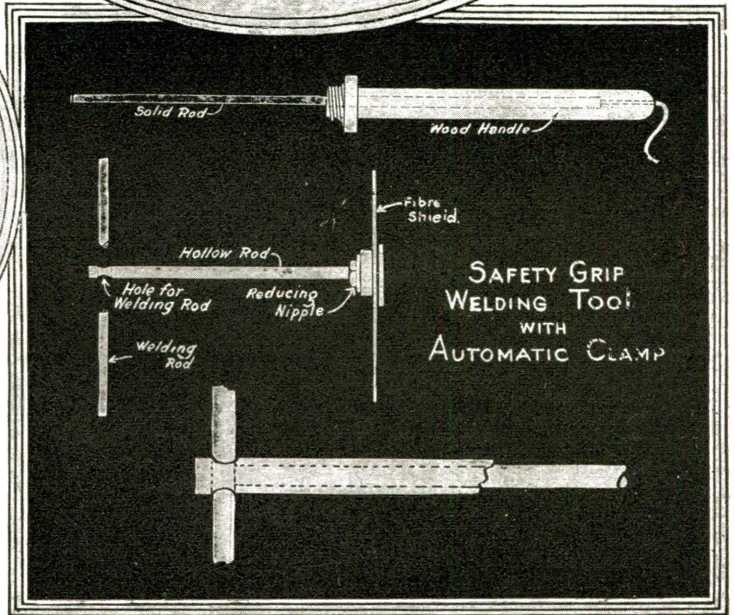

Drawing at Right Shows the Working Details of the Safety Grip Electric Welding Tool, with Automatic Clamp, as Built and Used by the Author with Success.

All materials used in constructing the arc welding clamp illustrated were odds and ends around the machine shop where the device is used. The first contrivance was merely a spring clip, which would often slip and was hard to adjust. The idea of improvement produced a somewhat better and safer handle which was developed by degrees into the one here shown, which is a time-saver and easy to operate.

The outer hollow tube encloses a solid rod which comes flush with the hole in the end of the rod. A slight twist of the handle threads the solid rod up tight against the welding metal rod, which is threaded thru the hole. Several sizes of welding rods may

The fiber shield cuts off some of the glare and flying particles as well as acting as an insulating stand when laying the handle aside.

The designers of this tool are working up an idea in which a magnetized coil with

distance above the job when working, so that the operation takes place within the magnetic field. With adjustments to the current the spread of the arc may be cut down to a point eliminating much of the glare, and permitting greater accuracy by the operator.

Saving Battery Expense

Some years ago, the writer was sent out on a hurry call to repair the call-bell system in a nearby small manufacturing establishment. On arriving at the plant, I found it to consist of two rooms, one of which served as office and shipping-room while the other served as the work-room or shop. Upon making myself known to the "boss", he showed me a simple return-call bell system between the office and the shop, all the while excitedly explaining that they had worked perfectly the day before, but which showed no signs of life at that moment. Fastened to the side of his desk was a highly polished nickel-plated buzzer and a very fancy brass push-button. Being handy to them I was tempted to pry off the cover of the buzzer and started to do so. It was a tight one, for it took two or three minutes before it popped off. With the cover off—I found the "works" of the buzzer practically "burned out". Every-

thing was charred and blackened, all insulation having entirely disappeared. Having received a secret clue to the trouble I removed the top of the push-button and found the contacts frozen together so hard as to make it almost impossible to pry them apart. This proved the clue that I had already found. Going out into the shop and examining the bell and button on that end, I found the same results. My mind was now made up and I set out to find the place where the bell system had gotten mixed with the lighting lines. Happening to look up over a work-bench I saw a box containing three dry cells. A drop light with several feet of extra cord hung down in front of this box and the extra wire was neatly coiled on top of the cells. Climbing up on to the bench I made a close examination, and found the cord to be bare of insulation in a number of places—which gave it the appearance of having been dragged over

something rough. Without disturbing it, I made an investigation of the battery binding posts and found them to be in contact with the lamp cord at two of the bare places. Of course, they were opposite sides of the circuit.

After having made this discovery, I called the "boss" and explained the whys and wherefors. I had to explain to him also why a common bell or buzzer would not operate for any length of time on a 110-volt system. It is needless of course to say that the lighting circuit was out of commission and had to be "re-fused." New apparatus was installed in place of the burned out material and the system put into operating condition again. When I reported the affair to the "Old Man" he figured it out as a fine joke and made out his bill accordingly—which was, by the way promptly paid.

Contributed by W. F. PERRY.

For Better Fans and Air Propellers

By H. M. DECKER

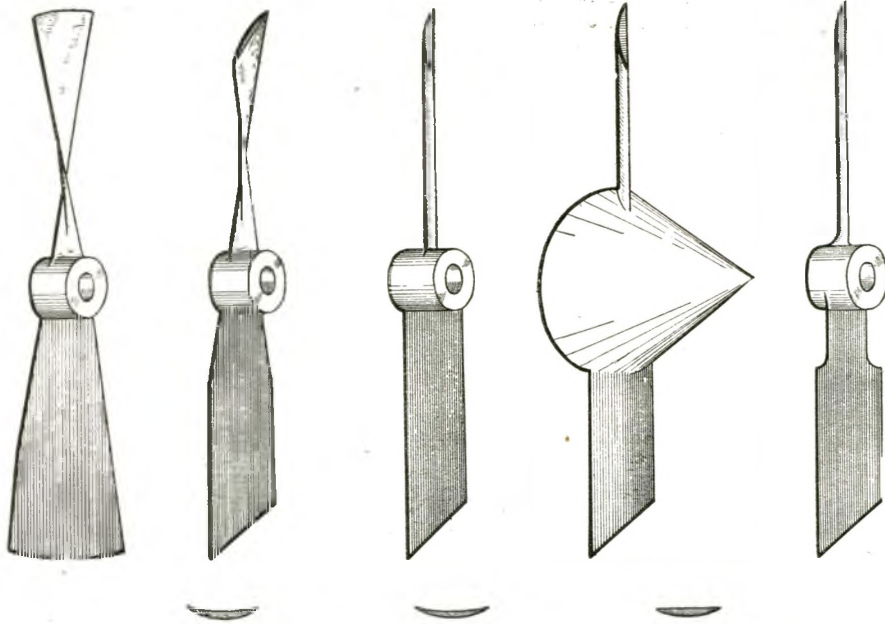

The Author's Experiments with Various Forms of Propeller Blades Intended for Use as Fans or Airplane Propellers, Either for Models or Commercial Machines, Are Outlined in the Drawings Above. The Author Suggests That to Get More "Push" Out of an Airplane Engine, Longer Blades Which Are Out Further from the Shaft and Act on a Larger Weight of Air, Should Be Used. This Will Reduce Propeller "Slip," the Common Source of Loss.

THE propeller uses the reaction of the air that it sends astern to move the airship ahead. The propeller thrust that drives the airplane is obtained by forcing a column of air tailward. For a given diameter that propeller is the best that gets the most *push* out of its engine. Likewise, with a given size of electric motor and fan guard the best fan turns out the greatest bulk of air. It gets the most push out of its motor which you feel as breeze.

Within the limits of my experiments to date, the simple form described in this article proved to be the most efficient. It is true it is not scientific and involved in appearance, but it is there with the performance.

The kind of blades tested had flat, true-screw and increase pitch or hollow driving faces of different widths.

Measurements were made on the shaft of an electric motor, of the power used, the air reaction or the thrust from the blades to the shaft, and the pressure on a large plane surface of the air current generated. Thrust and wind pressure were found to be proportional as would be expected.

Exploring the air movements around the blades while in action proves the air flow to be rotating before it reaches the blades. The air is drawn in from all directions—even radially toward the tips—crossing the blades diagonally and leaves in a stream that shows a maximum contraction at one or two diameters distance. All of which is like the flow of water from an orifice. An orifice located at the trailing edge of the blades would represent it.

A return eddy or whirl is created around the air column close to the blade tips. This eddy is reduced by cutting the blade tips off diagonally with a marked gain in efficiency.

The most efficient blades were those that imparted the least rotation to the air, and the worst were those that caused most twisting opposite the hub.

Most of my fans were made of wood and fined and trimmed to get the best form for that type of face. In all cases a two-bladed fan, with the width of each blade

equal to about one-ninth the diameter, gave the best results. And, when the blades were cut away for about one-third their length from the center of the hub so as to look like paddles or flattened spokes, there was a small further gain.

Use only two blades when the blade angle is less than 30°, and make the blades

flat-faced with the angle the same from the hub out, the width of each blade to be one-ninth of the diameter, the ends to be cut off diagonally, about 45°, so that the leading edges are longer than the trailing edges. Make the blades as thin as practicable and round off the back of wood or cast metal blades to meet the driving face in sharp edges.

If you want to get more *push* out of your airplane engine, try longer blades that reach out further from the shaft and act on a larger weight of air. This will reduce *propeller slip*, which is a common source of loss and waste power. But, if you are limited in diameter, the flat-faced design advocated here will give better results than any you have had and allow a "stick" to be made of one piece of wood.

Ventilating fans are fashionably designed with six or more curiously shaped blades. It takes power to cut the air up like that. Try results in your ventilator with a simple, two-bladed propeller, as described here, easily made of hard wood. It should be enough larger than the casing to bring the shorter following edges of the blades just in the opening. You will get more air, less noise and lower power bills.

If you want to get more breeze from your 16-inch electric fan, take off all but two opposite blades, trim the two remaining ones to a width of one and three-fourths inches, and cut off the blade ends diagonally to an angle of 45°, so that the leading edges are longer. Flatten the blades—that is, hammer out the dishing—and set them to the same angle. The fan will now run faster, propel more air, and use less electric current. Or set the two trimmed blades to a greater angle—say five degrees more, and you may get twice the air for the original consumption.

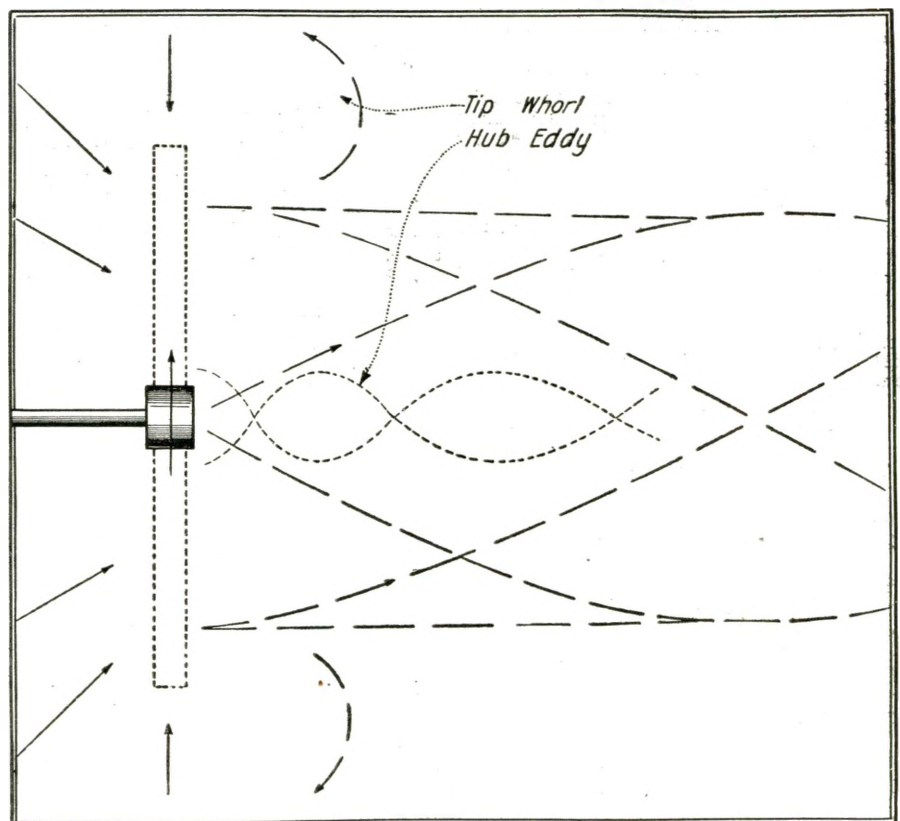

Analytic Diagram Showing Direction and Scope of Various Air Currents, Including the "Tip Whorl" and "Hub Eddy" for Rotating Propeller Blade. Much Can Be Gained by a Little Study of the Science of Air Propellers, Whether for Fan Blades or for Airplanes, as There Is Entirely Too Much Waste at the Present Time in Both of These Types of Propellers.

Building Machines Accurately

By EARLE W. GAGE

WHEN we are told to do or make things *accurately*, we cannot hope to know what the real meaning of the word accuracy is, as used in the great machine world, which converts raw steel into everything from automobiles, tractors, threshing machines, down to the finest instruments used in the medical field.

Let us say that two crankshafts are delivered to the inspection department of a machine shop of a modern American factory.

How the Micrometer, Snap Gage and Scleroscope Pave the Way

give fairly good service for a few months, or a year. But the tractor that is built to the highest standards will give the same satisfactory service year after year. It costs more to build these machines, but the time has come when Americans are willing to

nized as the standard of the machine world, are today far too crude for the careful machinist. Measure them with a micrometer that shows differences to thousandths of an inch; but even that is too crude for the scientist. Even after the possibilities of the most accurate measuring tools are exhausted he will still insist that if more accurate measurements were possible they would show differences. So that machinists and scientists both agree that, to make a certain part like another, is and probably

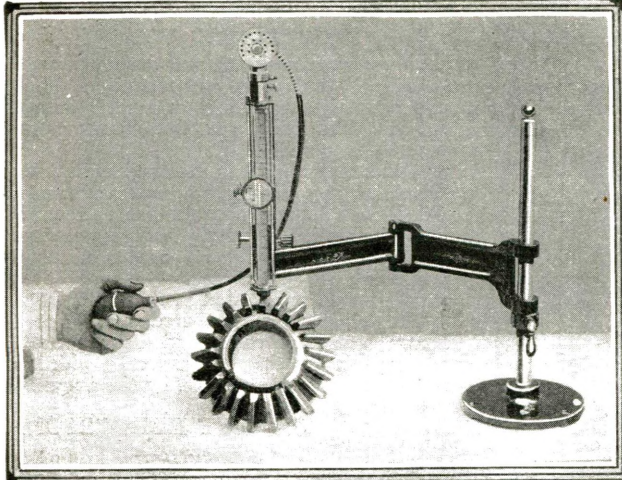

The Machine Shown Above Is Known as the "Scleroscope" and Is Used for Testing the Hardness of Steel or Other Metals by the Degree of Rebound of a Tiny Ball of Metal. This Ball Is Dropped from a Fixed Height to the Surface of the Metal. Rebounding Within a Glass Tube on Which Graduations Are Marked, the Reading Being Observed Thru a Magnifying Glass.

Illustration at Right Shows Large Size Micrometer Being Used to Caliper or Measure Accurately in Inches and Thousandths of an Inch, the Diameter of an Automobile Engine Piston. Such Parts Are Usually Ground and Polished on a Grinding Machine to One-thousandth-inch or Finer Precision. Instrument Below Can Be Used for Testing or Measuring in Thousandths of an Inch the Accuracy of Curvature on Round Parts, Etc.

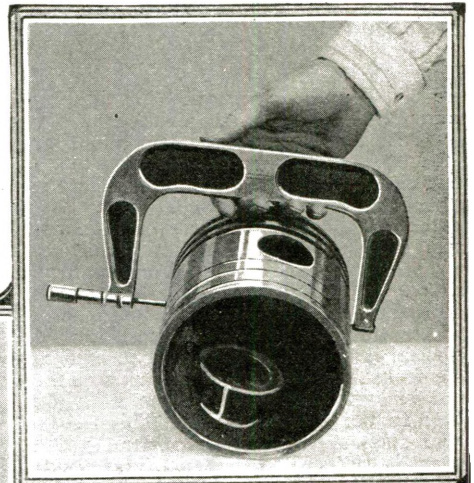
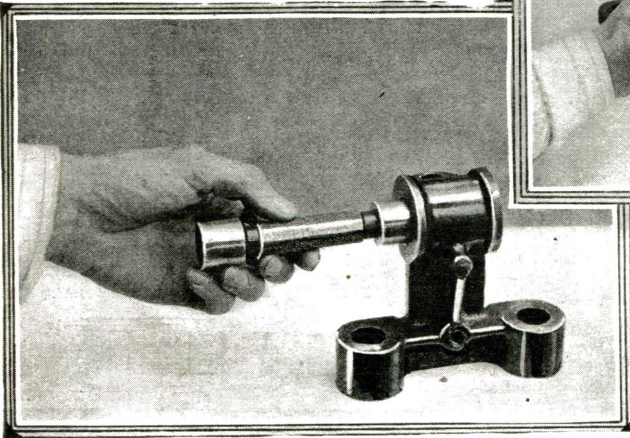
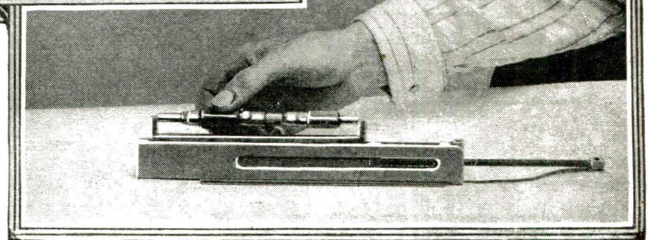

Photo Below Illustrates Tool-maker Using an Internal Micrometer or One Used for Measuring the Distance Between Two Surfaces. Micrometers Are Often Provided with a Vernier Scale so as to Read in Ten-thousandths of an Inch.



A Standard "Plug Gage," Thousands of Which Were Used During the War in Turning Out Standard Machine Parts Accurately.



To all appearances they are as near alike as the proverbial two peas in a pod. Ordinary standards of measurement reveal not the slightest difference between the two shafts. But when they come from the inspection department one is tagged "O. K.," the other is marked "Rejected." The one, measuring up to the exacting standards of perfection, is past on to form a part in the construction of an automobile or tractor—the other, varying from the first in degree of hardness that can be detected only by wonderfully accurate tests, or varying in measurement a fraction of the thickness of a human hair, is scrap—barred from ever taking a useful part in this busy world of affairs, fit only for the scrap-heap.

WHY ACCURACY IS ESSENTIAL IN MACHINERY.

Why all this accuracy? Why such rigid standards of inspection? To produce a tractor, let us say, that will give maximum service, longest life, freedom from breakage and delays. Almost any tractor will

pay for the better-built machine. And another advantage of accuracy in manufacturing is that it effects *standardization*, which enables owners of the machines to secure new parts when needed that will accurately replace the original parts of the machine.

Making parts to a standard does not mean that all parts are made to a hair-breadth exactness. One fact must first be recognized—that perfection in the eyes of the scientist is impossible. Take, for example, the piston of a gasoline motor. The design requires that this shall be of a certain diameter. The cylinder, too, must have a certain bore, and the dimensions of cylinder and piston shall allow sufficient *clearance* to permit the maintenance of an oil film between the two. But to make the piston the exact dimension called for is impossible, and to make a second piston exactly like the first is likewise impossible. Measure the two with a rule and they show no difference. But that is far too crude a method for even the roughest workman. Measure them with calipers—still no difference; but even calipers, long recog-

always will remain an impossible attainment.

Every part may vary from the set size, yet some vary more than others. Take, for example, a stove lid. If you break one you can get another to take its place. It may be as much as an eighth or a quarter of an inch larger or smaller, yet it serves all practical purposes. To make stove lids within a thousandth of an inch of a standard would be more costly, and no useful purpose would be served. But to permit an eighth of an inch variation in the size of a piston would be a serious error. The designer of a motor knows that to permit too wide variations from the standard results in a motor in which the parts are poorly fitted, causing excessive wear, vibration and strain, breakage, undue oil and fuel consumption, and other evils. Carrying the accuracy too far, however, means striving for an end that is practically unattainable as well as needless. But in the design of such machines as tractors and motor cars, accuracy is carried at present to the farthest practicable limits,

(Continued on page 926)

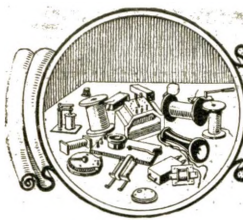

HOW-TO-MAKE-IT



This department will award the following monthly prizes: First prize, \$5.00; second prize, \$3.00; third prize, \$2.00. The purpose of this department is to stimulate experimenters toward accomplishing new things with old apparatus or old material, and for the most useful, practical and original idea submitted to the Editors of this department a monthly series of prizes will be awarded. For the best idea submitted a prize of \$5.00 is awarded; for the second best idea a \$3.00 prize, and for the third best a prize of \$2.00. The article need not be very elaborate, and rough sketches are sufficient. We will make the mechanical drawings. Use only one side of sheet. Make sketches on separate sheets.

FIRST PRIZE, \$5.00

A HOME-MADE ELECTRIC HOT-PLATE

Herewith is a diagram showing how I made an electric hot-plate. The heating element is composed of the metal from the stays of a Spirella Corset. Three to four of the stays work best on 110 volts alternating current. The drawing is to scale, the complete hot-plate measuring 8" x 8". The base of the apparatus is made of rigid asbestos shingles. They are easily cut to shape with a hack saw. Any size holes may be made by using metal drills. At each corner of the base is placed a porcelain tube. Thru the tube is a bolt which serves to hold the sheet iron grid in place. The grid is made from sheet iron by cutting slits in the metal and bending these pieces at right angles to the original sheet. This makes a fine support for utensils. The heating element is fastened to nails or rivets which are forced thru holes in the asbestos base.

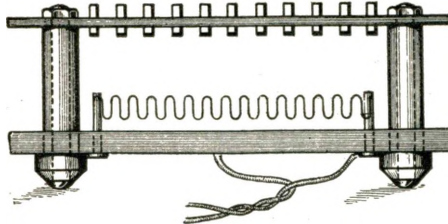
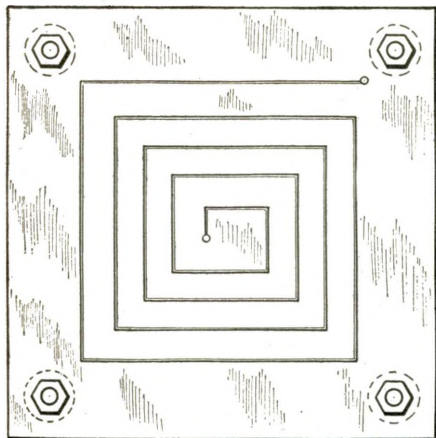

What Is More Useful Than an Electric "Hot Plate"? Here's How to Make One.

Complete the job with flexible cord and plug.

Contributed by W. W. MONTANO.

BUILDING ELECTRO-MAGNETS

The magnet core is best made of soft wrought iron or mild machine steel. The outside diameter of the coil should rarely be greater than three times the diameter of the core; in other words, the depth of the coil should be approximately equivalent to the diameter of the iron core. Enamelled magnet wire gives the most turns in a given space, single silk-covered wire the next highest number, and double silk next.

SECOND PRIZE, \$3.00

MYSTIC-COLORED SHADOW STAR

By means of an interesting experiment it is possible to show that, in certain circumstances, a colored shadow can be obtained

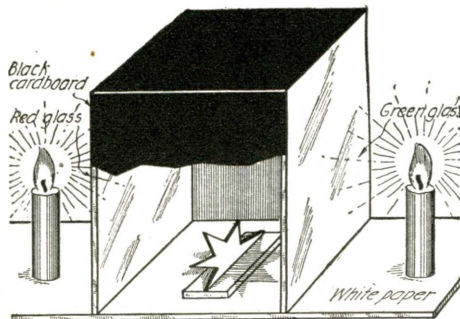

Arrangement of the Apparatus for Producing the Mystic-Colored Shadow Star—an Unusual Experiment.

from an opaque object. In the first place prepare a box formed of two sheets of glass (one red and the other green) and two pieces of black pasteboard. The sides of the box should be rather taller than they are wide and neither a top nor a bottom is required. Where there is any difficulty in getting colored glass plain sheets can be painted with the varnish dyes so widely sold for treating hats, etc. In this way very good colored glass can be prepared in any shade. The box might be of any convenient size; a good measurement for the sides would be about twelve inches wide by fifteen inches high. Now, from another piece of black pasteboard, cut out a shape similar to that shown in the diagram. This, as will be seen, is exactly half of an eight pointed star. The shape is fixt with an adhesive to a small flat piece of pasteboard so that it is held in a vertical position.

Place the box on a sheet of white paper. Then put a lighted candle on either side near to the glass. Extinguish all other lights in the room. Altho the rays of the candles pass thru the colored glass the light on the paper floor of the box is white. This is owing to the fact that red and green are complementary colors.

Put the shape into the box so that its flat sides face the glass in the manner shown in the diagram. At once a most beautifully colored star shadow appears on the floor of the box. One half of this is green and the other half red.

Contributed by S. LEONARD BASTIN.



Star Cut from Cardboard, to Be Mounted in the Center of the Box Shown in the Figure Above.

THIRD PRIZE, \$2.00

THE "MAGIC WAND"

Herewith is a sketch and description of a "Magic Wand" that will lift light objects and drop them at the command of the performer. But, mind you, this cannot change pictures into real stuff.

A cardboard tube, electro-magnet, two fountain pen flashlight batteries, and a small push button are all that is required. The sketch is so simple that no explanation is necessary for its construction. If you have no electro-magnet a suitable one can be made as detailed in the sketch.

The objects to be lifted must not be heavy, and for cardboard boxes, etc., a small piece of thin tin must be glued on them so as to be attracted by the magnet.

Contributed by GILBERT HENDERSON.

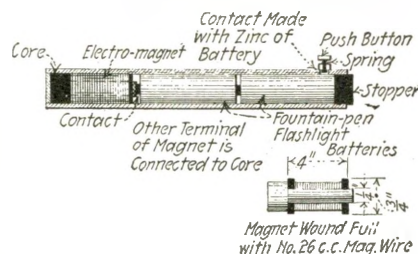

The Magic Wand Here Shown Can Be Built from an Old Electro-Magnet and a Fountain Pen Flashlight Battery.

NOVEL TELEGRAPH LINE

In these expensive times, when Old Man H. C. L. frowns with disfavor upon any attempt to install a telegraph wire line, the

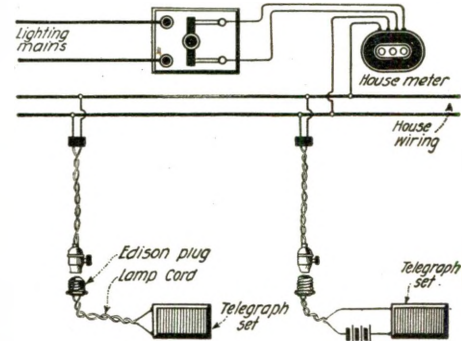

Telegraph Practise Sets Can Be Operated Nicely on Household Lighting Circuits if the Main Switch Is Opened.

following wrinkle may prove of use to the "Bugs" who have more brains than money:

Arrange two telegraph or buzzer sets as shown. Then disconnect the house wiring from the lighting circuit by opening the entrance switch or unscrewing the fuse plugs in the "cut-out." Then you can attach one of the sets to any socket in the house, attach the other set to any other socket in the house, and "get to work!" Practise will have to be confined to the daylight hours, when the lights are not wanted.

Contributed by THOS. C. McVEAGH.



Some Fascinating Experiments in Chemistry

By O. IVAN LEE

How to Make a Witches' Cauldron

Get a tin pie-plate and place it in the middle of the floor on top of half a dozen spools placed under the edge at equal dis-

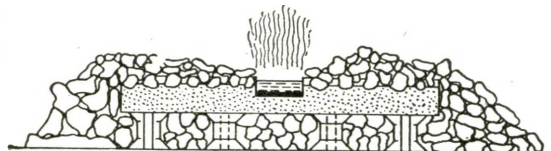

Arrangement for Safety as Well as for Effect in Using the "Witches' Cauldron."

tances. Pour sand or gravel on the pie-plate until about half full, smooth it over somewhat, and in the middle set the top of an empty baking-powder or cocoa can like a little well. Stick a lot of stones and pebbles in the sand and place some bigger stones on the floor around the rim of the pie-tin in order to hide it.

Now pour some wood alcohol into the little tin cup an inch below the top, stir in about a teaspoonful of boracic or boric acid (You'll find this powder in the medicine chest). Also add half a teaspoonful of salt to the mixture. Have everyone seated on the floor around the cauldron, put out all the lights and light the alcohol as you would do a lamp or gas light. Don't be afraid, because alcohol never explodes in an open dish; but don't forget that the fire is very hot. The flames will leap up several inches and will be colored a beautiful apple green and bright yellow. The light will make all your friends look so ghastly that you will scarcely know them. It is just the thing for Hallowe'en and ghost stories. There is no smell and only a very little white smoke which is quite harmless, so that the cauldron may be burned indoors without objectionable fumes. For convenience, however, it may be found advisable to erect the whole arrangement on a piece of sheet metal or even a board. One thing must be remembered very carefully, tho: *Never pour any alcohol into the cup while the fire is burning.*

How to Print Pictures on Apples, Tomatoes or Pumpkins.

If possible, select apples growing on the tree and of a variety which is known to be colored (yellow or red) when ripe. Pick out a dozen or so which are easily reached and have developed to full or nearly full size. They must, however, be green, or better, just beginning to show a tinge of color. See that they are smooth and firm, free from worm-holes, and firmly attached by the stem.

Now get some glazed black paper or some of that black paper which comes around camera plates and films, and cut out any silhouette figures which suit your fancy such as a swastika sign, initial letters, etc. If you are ambitious and clever with the

scissors, you may even essay dancing figures or something equally artistic. Do not make them too large—an inch and a half in height is about right. Now wipe the fruit with a cloth moistened in a little alcohol, and shellac the cut-out figures firmly and smoothly on the apples, favoring the sides which you think will get the most light. Some care will have to be exercised so as not to break the apples from their stems. When the paper figures are quite dry and show no signs of peeling at any point, go over them once with a light coat of shellac. This will effectually prevent dew or rain soaking the paper off. Little remains but "watchful waiting." Inspect your "prints" every day, repairing any curling which may occur. When the fruit has attained a decided color, pick and soak a few minutes in cold water, sponging off any shellac remaining with a little alcohol. You will find a sharp impression of your paper cut out in green on a yellow or red background as the case may be, the contrast being very striking.

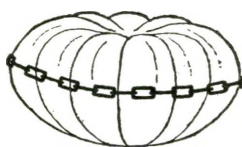

How to Write Your Autograph on Your Fruit—Then You Will Know It.

A Liquid Which Will Dissolve Cotton, Paper or Linen

From the druggist or electrician, get three ounces of some of those beautiful blue crystals called Blue Vitriol or Blue Stone. A more correct name is copper sulfate. Dissolve them in about a quart of cold water in a glass jar or vessel—a two quart fruit jar is convenient. Stir with a clean stick from time to time. It may take quite a while, even overnight, before the crystals are all gone, especially if they are large. Meanwhile, in a pint fruit jar, dissolve an ounce of soda lye or potash lye (the kind used for making soap), stirring with another clean stick, and afterwards screw the cover on until the blue solution is ready. Then slowly pour the lye solution into the copper solution, stirring all the while with a stick. A very pretty cloudy light blue substance will immediately be formed and after the lye is all in, will show a tendency gradually to settle down to the bottom of the jar. Enough lye should be added so that no copper sulfate is left to make a more or less clear blue solution above the blue substance.

Now comes a time when you will need the patience of a real chemist. When the blue compound has settled as far as it will go, take off the water above it, either by dipping it off very carefully with a small glass or porcelain cup or better by using a siphon.

(It is not advisable to try to pour it off.) For this you need only a rubber tube about eighteen inches long. Fill it *completely* with water, pinch both ends, slip one end into the water in the jar, keep the other below the level of the bottom of the jar, draining into the sink. When you release your fingers, you'll be surprised how easily the water runs up hill and down again. Don't kink the tube; keep the inside end under water, keep the lower (outside) end below the water level. Get off as much water as you can without disturbing the blue sediment, fill the jar with pure water and stir everything up again with the stick. When the blue precipitate has gone to the bottom again, drain off the top water as before, add more fresh water, stir and let settle. Repeat this washing process ten times after you can no longer taste anything in the water above the blue stuff.

Finally, after draining off the water for the last time, add ammonia water* to the blue residue little by little, stirring this time with a long piece of glass. It will slowly dissolve the blue mud and make a beautiful deep sapphire blue solution.

Pour off the deep blue liquid resulting and hold a piece of cotton in it. In a very short time the cotton in the liquid will melt like snow and disappear completely. Now try a piece of unglazed paper. It will dissolve like sugar in hot coffee. After this, try a piece of linen from an old handkerchief or napkin. Presto! and it is gone! But if you put a piece of wool or silk in this wonderful solution, nothing happens, because they are of animal origin and very different chemically from the cotton, paper and linen of the vegetable kingdom.

*Household ammonia will do nicely, provided it is pure and clear and hasn't any soap, etc., in it. Anything of this kind can be detected by letting a spoonful of ammonia evaporate in a saucer near the stove. Pure ammonia solution will disappear and leave nothing behind.

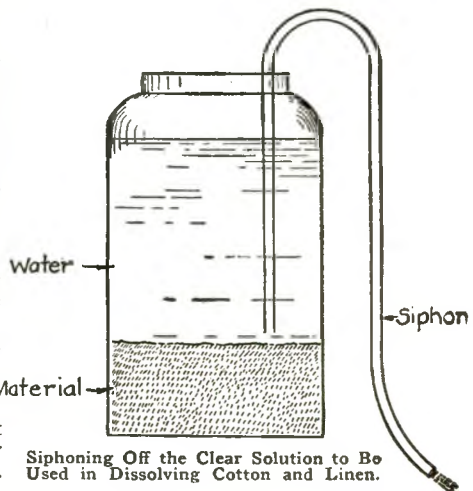



RADIO DEPARTMENT



The Nauen Radio Station

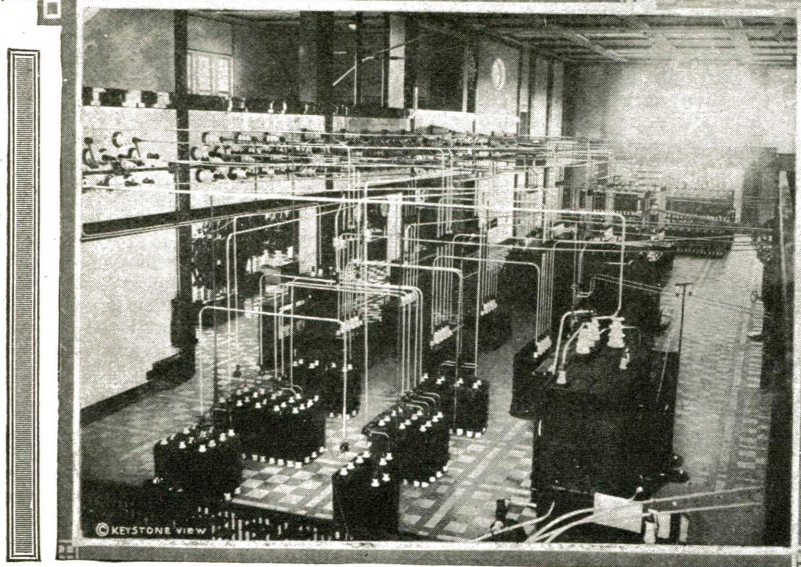
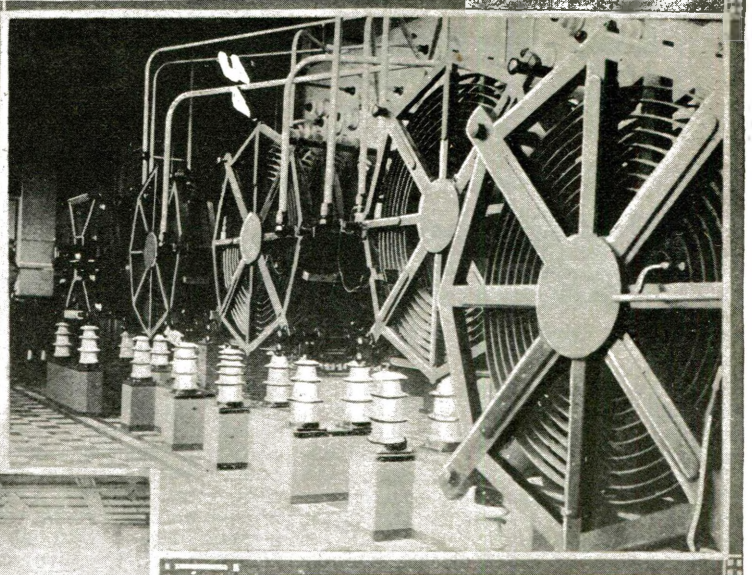
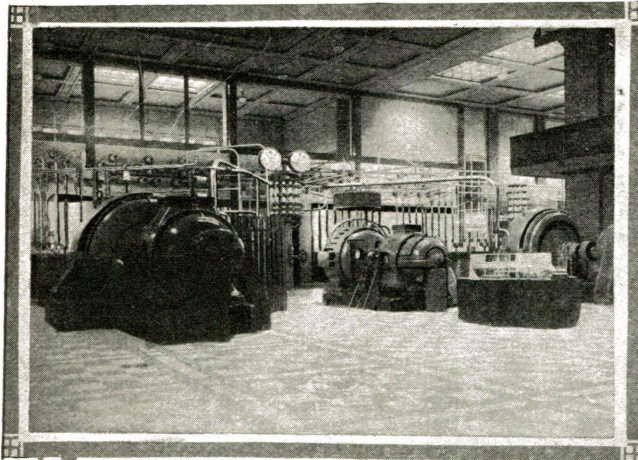

Upper Left-hand View Shows the High Frequency Dynamos in the Transmission Station at Nauen. It Will Be Noted How Carefully and Artistically the Apparatus Is Laid Out With Inlaid Rubber Floor Mats to Protect the Attachés From Shock When Touching the Machines While in Operation. In the Center of This View Can Be Seen a Centralized Switch for Directing the Energy From Each of the Dynamos to the Condenser and Other Power Rooms.

View Above at Right Shows a Close-up of Some of the Inductance Coils Used in Tuning the Powerful Transmitter at the Nauen Station. Note How the Inductance Spirals, Composed of Flat Copper Ribbon, Are Rigidly Mounted on Insulating Frames, Which Are in Turn Carefully Supported and Insulated on Porcelain Petticoat Insulators.

View at Left Gives Some Idea of the Extreme Care With Which the High Tension Bus-bars in the High Tension Transmitting Condenser Room Are Arranged. The Condenser Plates Are Immersed in Oil in Steel Cases.

IN a recent article describing the great Nauen wireless installation, a German journalist says: "Lessing has asserted that to him it seems the greatest of wonders that true wonders become everyday affairs to us and that they have to become such."

Nauen, he says, was *once* a wonder; now it is a telegraph station. It communicates with the other great stations of the world and is now in public service, undertaking to telegraph or transmit messages in the order in which they are received. Its construction dates back to 1906, when the original building with an experimental outfit was erected, and it is said that in those days the ear drums of the operators suffered more than did the ether on account of the piercing noise produced at each make and break of the key.

At present it is claimed that the great building no longer covers anything experimental. It no longer shelters a laboratory, but covers a perfected apparatus for producing ether waves.

The president of the German republic sent out a wireless message, directed "An Alle," which means "to all." Two hours past and answers came in from all over the world—Rio de Janeiro, Pekin, Shang-

hai, Santiago in Chili, Java and from any number of nearer stations.

The question is then asked by the writer: "Is *that* a wonder?" and he illuminatingly adds that for Nauen it is no wonder, for such is only its daily work.

Nauen has to take care of 10,000 wireless messages monthly.

The great Nauen station was officially dedicated on September 29 in the presence of a distinguished company of engineers and government representatives, among whom was Mr. Ellis Loring Dresel, United States Commissioner to Berlin. The company present included members of the American Commission as well as representatives of several other countries and newspaper reporters from American, and German journals.

The President of the German republic, Ebert, who spoke at the official opening and dedication of the Nauen station, highly commended the builders of the station on their skill and ingenuity. The design of the plant involves some of the very latest features in European radio developments. The mast and aerial, which are used to communicate with the Americas and which have just been completed, are claimed to have

a range of 12,000 miles and a transmission speed of seventy-five words per minute.

A remarkable and interesting feat was the official opening of radio communication between Buenos Aires, South America, which was inaugurated with the transmission of a message from the Nauen station, address to President Irigoyen.

The three accompanying views of the famous Nauen station gives some idea of the magnitude of the high-power radio apparatus in use. The upper left-hand view shows the high frequency dynamos in the transmission power room. It is interesting to note how carefully and accurately all of the apparatus is arranged—whether it be condensers, inductances or the dynamos themselves. From the inlaid rubber-covered floor to the panelled ceiling above, everything is well taken care of both artistically as well as mechanically and electrically. The rubber-covered floor is quite essential to safeguard station operatives from receiving severe shocks when touching some of the machinery which may be highly charged.

An excellent specimen of high tension wiring is that shown in the lower view.

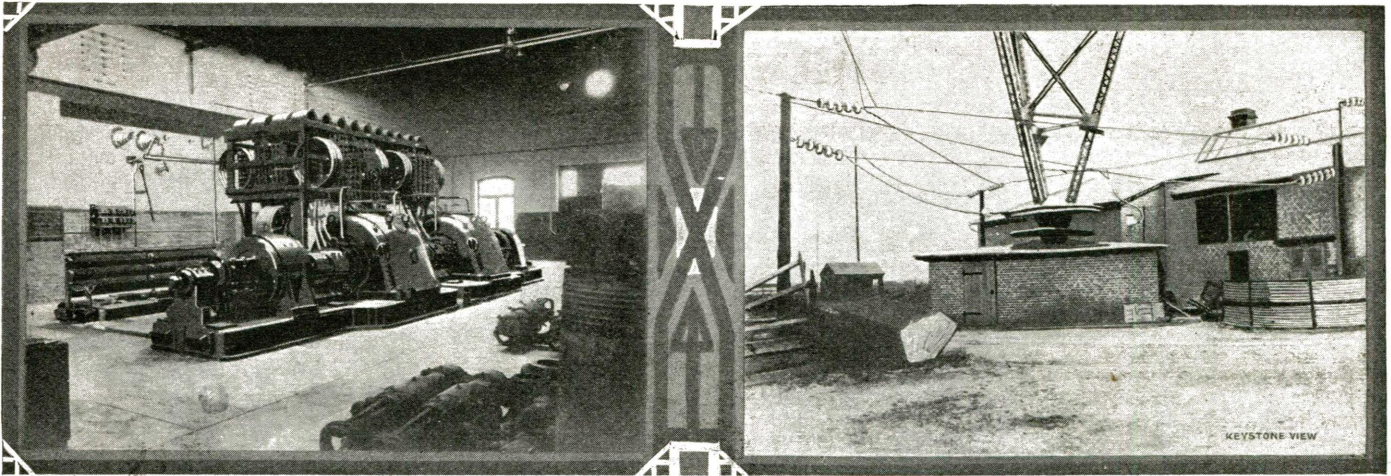

View of Radio-Frequency Room at Eilvese Station, Germany.

The Base of the Aerial Mast is Placed on a Gigantic Insulator.

Eilvese Radio Station

THE accompanying two photographs show an interior as well as an exterior view of the powerful German radio station at Eilvese, near Hanover. The exterior view shows the foot of the steel mast which is arranged to rest with its triangular point on a gigantic insulator. In most of the stations having an aerial mast constructed on this principle, the steel mast itself is used as part of the antennæ, which is permissible as will be seen by the fact that it is insulated from the ground, owing to its peculiar construction as just explained.

Practically all large stations such as this one, use a ground in the form of a counterpoise, which comprises a series of copper wires, connected like the spokes of a wheel, directly under the aerial and covering a similar area of ground. These wires are all connected together at the center, which is usually at a point directly under the radio station building, and which central connection is used as a ground terminal. The wires are invariably buried a foot or two in the ground and care is taken to se-

cure damp soil and if dry, it is soaked with water daily.

The interior station view is an interesting one as it shows the remarkable care with which the machines have been arranged—the generators shown are radio frequency alternators of the type devised by Prof. Goldschmidt. The Goldschmidt alternator has met with great respect on the part of radio experts in Europe, but it has given way to a much simpler and more easily built machine known as the Alexanderson alternator in this country.

The difficulties met with in operating the Goldschmidt alternator, which produces a very high frequency current of 50,000 cycles per second or more, are principally the very high speed at which it is operated—and particularly the extremely small clearance between the rotor and the stator, which means that the rotor has to be very accurately mounted and balanced on its shaft so as not to hit the field and destroy or injure the machine as it rotates. The American naval experts at the Tuckerton, N. J., station during the war, found that

it was quite difficult to keep the machine in perfect tune, owing to slight yet readily perceptible changes in the speed, and the corresponding changes required in the tuning condensers and other apparatus with which the Goldschmidt alternator is equipt.

The Goldschmidt machine as it was built in the German factory is a very fine piece of workmanship. In fact, it was said at the time when the first machines were turned out, that they marked a new exactitude in machine construction. The clearance between the rotor and the stator was so slight that a piece of ordinary writing-paper could just be placed between the rotating and fixed members.

Some idea of the ingenuity and skill exercised in building one of these machines can be imagined when it is realized that the rotating member weighs several tons, and rotates at several thousand revolutions per minute. A good illustration is to imagine a machine almost as intricate as a fine watch, with its rotating parts magnified 10,000 times in mass.

Secretary Baker's Son a Radio Enthusiast

The accompanying photograph shows development of the vacuum tube. Today having a pedigree as long as your arm, and it is possible to procure a vacuum tube for special compact radio sets, either transmitting or receiving, there are available vacuum tubes as small as one-half inch in diameter by one and one-quarter inch in length.

Master Baker has a radio outfit placed on his "bike," and while riding about Washington he receives messages from Arlington and other radio stations. He recently stated that he intends rigging up a transmitting set so that he can communicate with his home while riding about town.

Automobile and bicycle radio stations have slowly but surely come more to the front in the past few years than was ever thought possible by the early workers in radio telegraphy, which is due of course to the greatly improved detail in the apparatus, and particularly to the rapid strides made in the

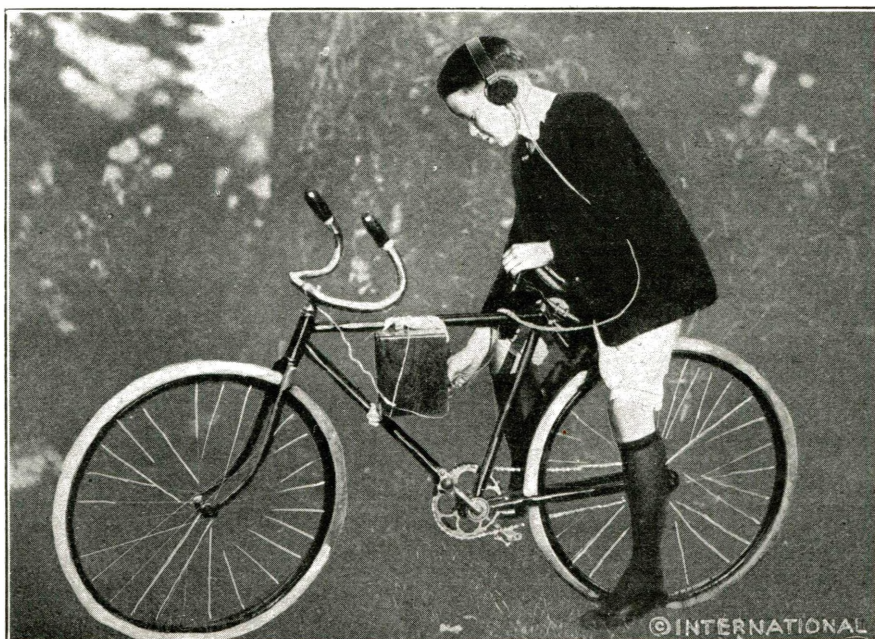

Youthful Son of Secretary of War Baker, With His Bicycle Radio Set.

Some few years ago radio experimenters endeavored to put transmitting sets on their bicycles or automobiles, but they had to make arrangements for carting along a formidable and weighty pack of instruments, including at least one-half dozen heavy dry cells and a spark coil giving at least a one-inch spark, besides condensers, helices and other apparatus, which all had to be designed of sufficient size to give a good spacing between the turns in order to withstand the high voltage employed.

All this is now happily changed.

New Precision Condenser and Wavemeter

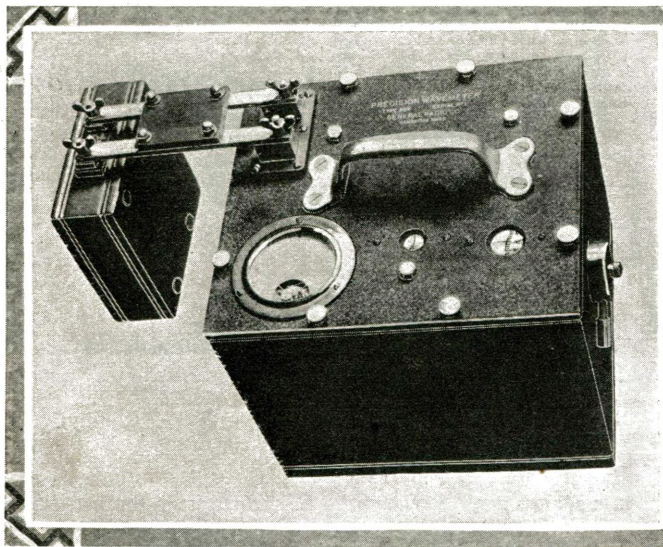

New Precision Wavemeter Designed for the Use of Students and Engineers Who Desire the Highest Accuracy in Making Various Wave-length, Inductance and Frequency Measurements. This Wavemeter Comprises a Very Accurate Plate Condenser as Well as an Inductance and a Thermo-galvanometer. No Buzzers or Other Paraphernalia are Included in the Circuits; Thus Providing an Instrument Having a Minimum of Leads and Permitting Their Resistance to be Made Negligibly Small. Range Is 75 to 24,000 Meters.

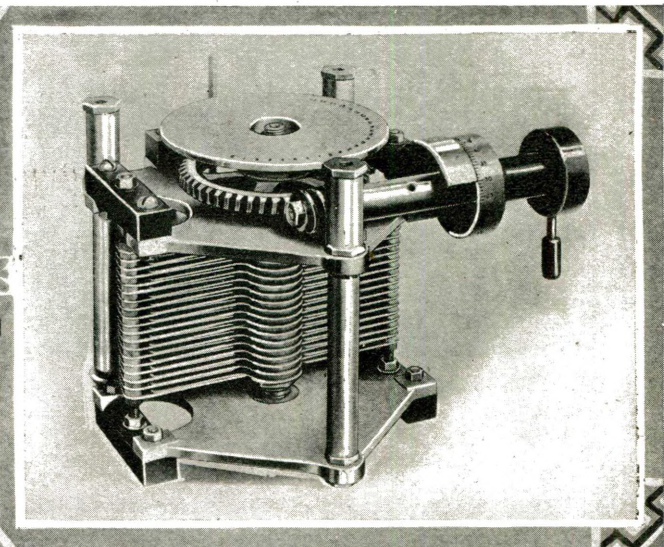

View Above Shows the Fine Workmanship on New American Built Precision Condenser. This Condenser is Suitable for All Kinds of Radio Work, and Particularly for High Class Receiving Sets and Various Radio Measurements. It is Provided With Two Finely Graduated Dials of the Highest Accuracy, and the Slightest Movements of the Rotary Plates can be Effected by Means of the Worm Wheel and Gear Shown, the Worm Being Turned by the Insulated Handle Shown at the Extreme Right.

CONDENSERS used as standards and for precision measurements must have many features not usually found in ordinary laboratory condensers. For variable standards it is essential that the plates be sufficiently rigid and well spaced so that handling of the condenser will not cause a change in capacitance. It is not alone sufficient that the power factor be low but it is also important that the dielectric losses be substantially constant throughout the entire range of the condenser.

The precision condenser is not intended for use as an ordinary laboratory experimental condenser, but rather for those places where precision is essential. In its design the mechanical as well as the electrical features have received special attention. There are two sets of substantial semi-circular aluminum plates with wide spacing. The steel shaft runs in brass cone bearings, which are positively locked in position. After assembly of the entire condenser the shaft is rotated for several hours to insure its perfect alignment and the wearing in of the bearings.

The rotary plates are turned by a worm and gear, thus permitting fine control. The worm is held by spring tension in position against the gear to prevent backlash due to wear. This is the same method used in accurate dividing engines. The rotation test referred to above includes the worm and gear so that they are well worn into place before the condenser is accepted. Attached to the main shaft is a scale, 180 degrees of which are divided into twenty-five equal parts. To the worm shaft is attached a second scale the circumference of which is divided into 100 equal parts. Since one complete turn of the worm shaft moves the main scale through one division, the position of the rotary plates may be read directly to one part in 2500. As the divisions on the sub-scale are placed 1/16 inch apart it is possible to estimate easily to fifths.

Since there is only a small amount of solid dielectric used in the entire condenser, and since this dielectric is carefully selected, and is all placed in a weak electro-

static field, the power factor is very low, being approximately .01 per cent. at a capacitance of 1500 micromicrofarads. As the dielectric is not in the direct field of the rotary plates it is not influenced by their position. Thus the dielectric losses remain nearly constant throughout the entire range of the condenser. This is a particularly valuable feature in measurement of the properties of dielectrics. It permits the assumption that the condenser is equivalent to two parallel condensers, one of which is fixed and has all the losses and the other variable and has no losses. This condenser is adapted for use with potentials up to 1000 volts. With each condenser is a calibration table giving the calibration with an accuracy of .01 per cent. for twenty-six points.

fitted with a carrying handle. In order that the condenser may be kept free from dust the two scales are read through glass windows set into the aluminum top. A hard rubber rotating handle extends into the box and engages the worm shaft.

Remarkably Accurate Wavemeter

Similar in general design to the Precision Condenser is the new Precision Wavemeter here illustrated. Accuracy and permanence of calibration are cardinal features of this instrument. To insure this accuracy under all conditions no extra circuits such as a buzzer or detector are incorporated in the wavemeter. There is but one circuit, the calibrated oscillating circuit, which consists of a condenser, inductance, and thermo-galvanometer. Such an arrangement requires a minimum of leads and permits their resistance to be made negligibly small.

The condenser is the precision condenser previously described, with a capacitance of 1500 micromicrofarads. The low losses of this condenser permit the obtaining of a very sharp resonance point. The scale arrangement, consisting of a primary scale and a sub-scale, is the same as used on the precision condenser. This arrangement permits a direct reading of capacitance to one part in 2500. When measuring the wave-length of a vacuum tube or other undamped oscillating circuit, it is possible to determine the resonance point to better than one-half a division on the sub-scale which is equivalent in wave-length to one part in 10,000.

The inductance coils are wound with stranded wire with the separate strands insulated from each other. Five coils are furnished covering a range of from seventy-five meters to 24,000 meters with a good overlap between coils.

Resonance is indicated by means of a Weston thermo-galvanometer mounted in the top of the condenser case.

Wave-length data is furnished for twenty-four points with each of the five coils. Capacitance data is furnished for twenty-six points on the condenser.

Articles to Appear in December Issue of "Radio News"

The Eiffel Tower Radio Station
By a French Radio Engineer

*A Three Tube Combination Radio-
phone Transmitter and Receiver*
By Robert E. Lacault

Pocket Radio Receives Time Signals
How We Came to Have a V. T.
Transmitter on the U. S. S. Princess
Matoika

By Chief Operator Daggett
An Amateur Trans-Oceanic Feat as
Reported by Pierre H. Boucheron

A Practical Receiver
By Volney G. Mathison

A Christmas Presentation
By Erald A. Schivo

The case is of polished mahogany and is lined with a copper shield grounded to the rotary plates. A 1/4-inch aluminum plate finished in a permanent crystalline black forms the condenser top. Other metal parts are finished in polished nickel. The top is

Transmitting Photographs By Radio

By PIERRE H. BOUCHERON

IT is a curious fact that English, French, Italian and German radio engineers who are hampered more or less by stringent radio laws should be so far ahead in that branch of radio devoted to the transmission of illustrations by means of radio waves than we Americans who are blest with more generous and certainly broader radio laws and regulations.

Paradoxical as it may seem, our apparent lack of interest is probably due to these better laws of ours which are so broad in comparison to those of European countries that we are indolently laying back, as it were, imbued with the spirit of *laissez faire*. We may say to ourselves, "Let others look into the matter; we have our hands full at present with VT transmission of both speech and telegraphic signals; we are not ready for radio photography; when the time comes we shall look into the matter."

This philosophy, if so it be, and if the writer is right in assuming it to be the present state of mind of our radio research

A General Exposition of the Problems Involved and How Some of Them Are Solved in the Martin System

which, tho still in the laboratory, give great promise of emerging into the commercial field, particularly that having to do with the transference of international news items.

THE WIRE METHOD.

Many of us, when the subject of radio photography is mentioned, naturally enough will ask what has been done in the matter of first developing the land wire system of telephotography. The statement may be

expanses of water. Naturally enough, we think of the submarine cable, but here we are met with still greater undesirable capacity effects. It is said of the cable that the electrostatic capacity of one mile of its length is equal to the capacity of 20 miles of overhead wire. This large capacity effect of the cable retards the transmitted impulses of energy to such an extent as to considerably reduce operating speed. Thus, telephotographic distance experiments with the cable are so much reduced as to be unworthy of serious efforts in that direction.

With what has been previously said, and judging from present indications, it is both timely and logical that attention should be directed to the employment of radio as a medium for the transference of energy needed to transmit impulses corresponding to the black-and-white variety of shadings of a photograph or other illustration. Since great distances would seem to be the goal toward which telephotography would strive in order to become useful and practical,

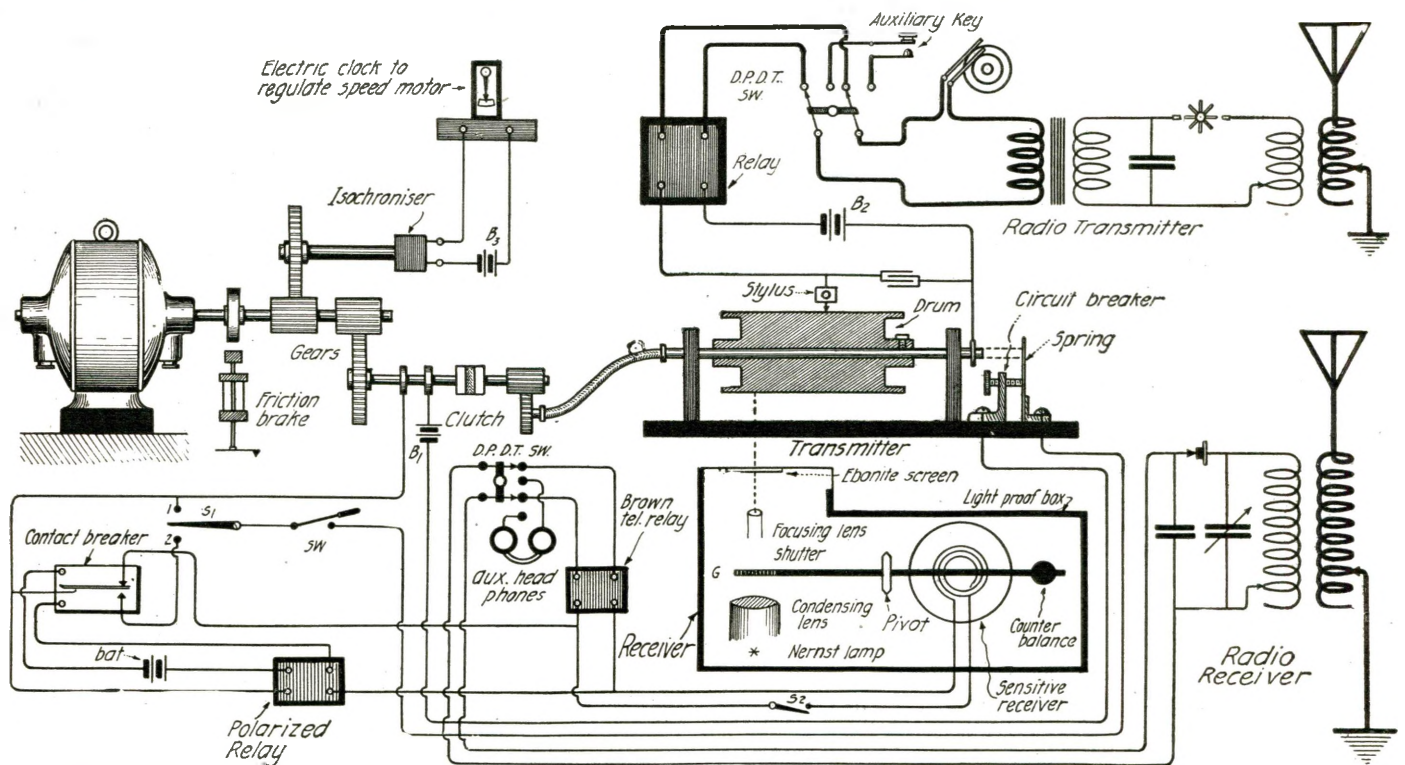

This Diagram Shows Some of the Interesting Details of the Martin System for Transmitting Photographs, Drawings, or Script by Radio. This Diagram Shows the "Receiving" as Well as the "Transmitting" Apparatus. The Photograph is Prepared in the Form of a Cross Lined Metal Plate or Cylinder Over Which a Stylus Passes, as Seen. The Successive Impulses Are Transmitted by Radio Waves and When Received, They Are Caused to Act Upon a Sensitive Electro-Magnetic Shutter Arrangement, in Such a Manner That the Picture is Reconstructed, Dot by Dot, so as to Cause Light and Dark Shades to be Imprest Upon a Sensitive Photographic Film in the Identical Order of Their Original Transmission.

men, would seem to be decidedly an unhappy one. While we are thus browsing on the hillside of this branch of radio, our European contemporaries are making such rapid strides that some fine day in the near future we shall find ourselves in the proverbial rôle of the hare whose cocksureness over his adversary, the turtle, caused his defeat in the matter of a simple race which he could easily have won had he been less sure of himself.

These remarks are not idle jesting. There is hardly a foreign technical paper reaching this country which does not mention some new development or some new appliance slowly but surely paving the way to ultimately successful and commercially practical radio photography. Let us, therefore, be on our guard, as there are today several foreign experimenters systematically perfecting some already excellent methods

made that until such time as this system is a practical one in the sense that wire telegraphy and telephony are, there is no advantage to be gained by trying to apply the method to the less concrete and certainly more elusive Hertzian waves when so little is known about the early wire system. This may be answered in the following manner:

In the present methods of quick and certain mail deliveries accomplished by fast transcontinental trains and by still faster airplanes, there can be no great advantage in devising a somewhat sluggish system of telephotography applicable for short distances only. The use of long wires, on the other hand, those of 1,000 miles or more, involves the undesirable encountering of capacity and inductive effects. The exchange of illustrations, therefore, is more needed between distant nations separated by great

an accurate and dependable radio method should turn out to be much more economical and speedier than telephotography as applied to regular land lines and cables.

From the above it must not be inferred that the transmission of photographs thru the medium of electrical conductors is not a practicable thing. During the past few years, and particularly before the great war, excellent results were obtained by wire over distances slightly exceeding 400 miles and by submarine cables, such as the one connecting London and Paris. In these experiments speed reduction on account of line capacity was greatly overcome by the use of special apparatus; but, after all, it is a question whether ultimate results warrant further research with line systems when radio offers considerably better inducements. Thus we proceed to radio photography

(Continued on page 932)



WITH THE AMATEURS



Our Amateur Laboratory Contest is open to all readers, whether subscribers or not. The photos are judged for best arrangement and efficiency of the apparatus. To increase the interest of this department we make it a rule not to publish photos of apparatus unaccompanied by that of the owner. Dark photos preferred to light-toned ones. We pay \$5.00 each month for the best photo or photos and \$2.00 to each "Honorable Mention." Address the Editor, "With the Amateurs" Dept.

"Amateur Electrical Laboratory" Contest This Month's \$5.00 Prize Winner—Gilbert Carter

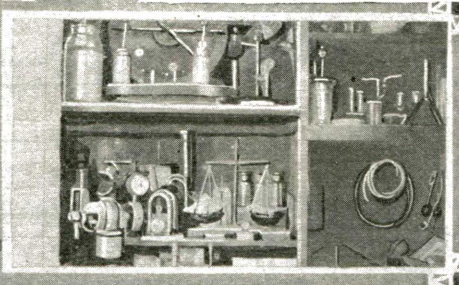
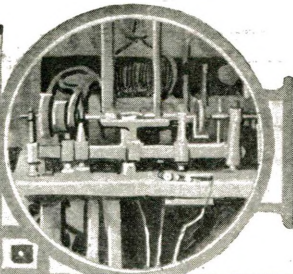

which are used in compounding photographic formulæ.

The chemical apparatus consists of the usual flasks, beakers, etc., also a desiccator, Liebig condenser, copper retort for oxygen, wash bottles, crucibles, a horn pan balance and a platform balance with metric weights up to one kilo.

The electrical apparatus comprises a Toepler-Holtz static machine with accessories, which is run by a small water motor shown in one of the photos. I also have a 110-volt D.C. generator, several small motors and generators, induction coils, an Oudin coil and other odds and ends of every description. I perform many physical and chemical experiments, including simple chemical analysis.

One photo shows a corner of my workshop, containing a small lathe and grinder with counter-shaft. I have a small D.C. generator (not shown), which is also belted from the countershaft. I

THE three accompanying photographs are views of my electrical and chemical "lab," my workshop and my radio apparatus which I desire to put into the contest. The chemical cabinet contains about one hundred and fifty chemicals, including acids, salts and reagents, many of

use this lathe mostly for woodturning and polishing.

I have spent many enjoyable hours in my laboratory and workshop with the help of the SCIENCE AND INVENTION magazine, and the usual text books.—Gilbert Carter, Box 330, New Hartford, Conn.

Honorable Mention—Raymond McCormick, \$2.00 Prize

THE photos herewith show my chemical and electric "labs;" also my "study" at my home in Lincoln, Nebraska. At present my chemical "lab" is of the greatest interest, as I have recently performed some exciting experiments—you know, explosions, etc.

I have a good variety of chemicals and apparatus, including some balances which are accurate to a fraction of a grain, also a microscope, which comes in handy in analytical work.

My electrical "lab" boasts of a complete receiving outfit, with which I can catch Arlington, Key West and other equally large stations.

By getting "wireless time" I am able to keep all of the clocks in my house correct. A Brandes 2000-ohm head set, a Murdock variable condenser, a fixt condenser which I constructed myself, and a 3,500 meter loose coupler receiving transformer make up my receiving outfit.

I also have a small sending outfit. Some of my other *junk* consists of motors, buzzers, bells, electro-magnets, a telephone receiver and transmitter, numerous batteries, many sizes of wire, part of an automobile ignition system, a Morse telegraph key and sounder, a couple of spark coils, an electric fan and other materials, favorites with "bugs" like myself.—Raymond McCormick, 1238 "P" Street, Lincoln, Nebraska.

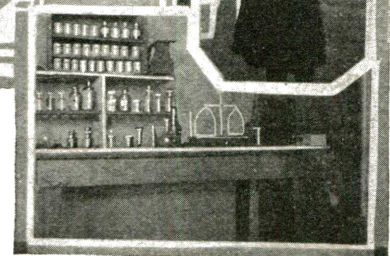

What to Invent

By JAY G. HOBSON

RECENT accounts of the great loss of life in hotel fires remind us that more and better protection should be given guests stopping at up-to-date hostleries, and proper safeguards for use in case of sudden danger should be provided. While the law requires all public buildings to maintain fire escapes and to display notices or red instruction signs and lights in the hallways leading to the exits yet on close observation it will be seen that the system now in use is far from safe and satisfactory.

I have in mind several prominent hotels of the most modern type boasting of their fire-proof construction, but such protection as provided is only good so far as it can be used properly and quickly in case of urgent need.

How many travelers ever give passing notice to the location and operation of fire escapes upon renting their rooms? I believe it is safe to say not one in a hundred knows how to get out in case of fire, because they only think of such catastrophes when the great danger knocks on their own door, at which time they usually lose control of themselves and many perish, if the fire is of a serious nature.

For this reason, if for no other, an improvement in fire protection for hotels is greatly needed. An improvement or device to think for the thoughtless could be used with great saving in life and property.

In each room, secured to the wall in plain view, should be established a small *Electric Fire Guide* operated from the office downstairs to warn the guests of fire individually and to give them easily understood directions how to save themselves, which way to go, where to go, how to get out and when to go!

The mechanical construction of this device

details of escape. Travelers learning of the hotels with such thoughtful protection for

lowered. This construction would not be complicated, as a proper placing of gears

Mr. Hobson Here Illustrates and Describes in the Accompanying Discourse, a Most Invaluable Improvement in Our Hotel Service, Especially When It Comes to Conflagrations. Anyone Who Has Ever Been Caught in a Hotel Fire Will Appreciate the Fact That We Really Need Something Better Than the Present System. Mr. Hobson Suggests an Electric Fire Alarm Signal and Bell to be Placed in Each Room, So That by Turning a Single Switch at the Clerk's Desk, All of the Signs Will Light Up and the Bells Start Ringing. The Signs Indicate in Which Direction the Guest Should Turn to Locate the Nearest Fire-Escape.

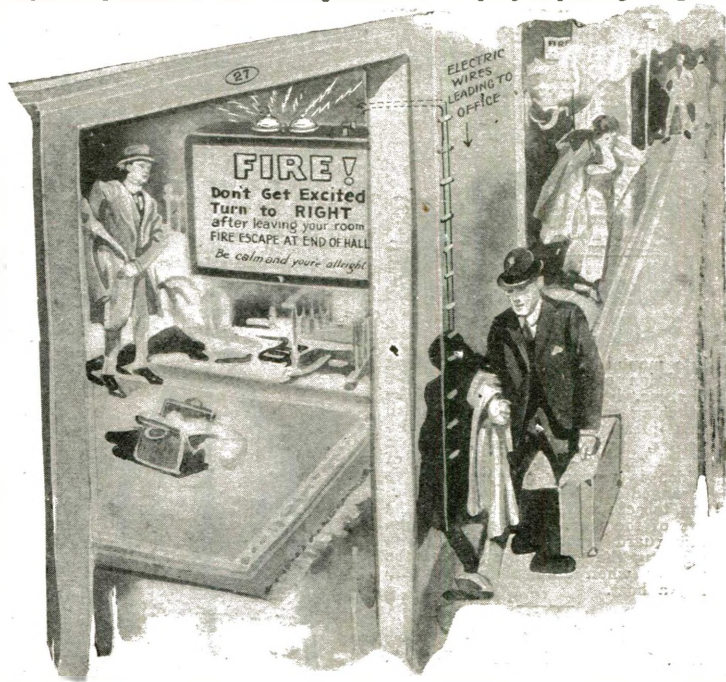

themselves and families would prefer to patronize this kind, even though such installation might necessitate slightly higher rates of accommodation than hotels without it.

Automatic Phonograph Winder

If you own a man-wound phonograph, you will readily appreciate the significance

connected to the phonograph spring and the metal cover support would so enlarge the ratio that the distance required for the cover support to travel would only be of such length as the present machine lid travels when raised and lowered.

The illustration will make my idea clearer. Undoubtedly an improvement of this class would meet with instant favor both with the manufacturer and the phonograph public, because of its convenient and novel features.

Improved Cigarette Holder

Anatomists maintain that the harmful effects of cigarette smoking come from inhaling the hot smoke containing nicotine in
(Continued on page 912)

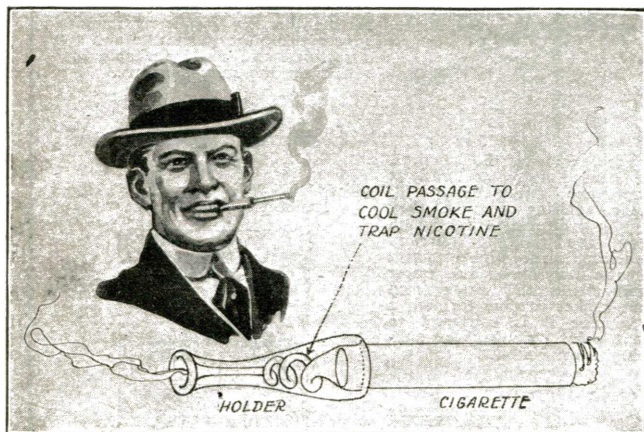

For Those Who Smoke, the Present Suggestion for an Improved Cigarette and Cigar Holder Will be of Interest. It is Well Known That Lip Cancer Has Often Been Caused by the Hot Cigar Holder or Pipe Stem Held in the Mouth, and Not Only is This Objection Overcome in Mr. Hobson's Suggestion Shown in the Accompanying Illustration, but He Has Also Provided a Nicotine Trap, Which to Function Properly Should be Cleaned Thoroughly and Frequently of Course. Certain it is that there is a small fortune awaiting the man who will invent something real new and thoroughly efficient in the line of Smokers' Supplies.

would be simple and the device itself could be easily manufactured. The *Fire Guide* could be made of an oblong metal box with a small red light and a bell enclosed, and the front part of the box would be of glass, with words of direction and instruction painted thereon.

Wires from each guide box would connect to the control board downstairs in the lobby. In case of danger the operator throws on the master switch which immediately lights all the red lights in each guide box and rings the warning bells. The guests, of course, are awakened gently by the persistent, yet not exciting alarm, and read the direction on the illuminated guide box which is plainly visible.

Having the instructions directly before them while dressing, enables the mind to grasp the facts firmly and thereby remember

and importance of this suggestion for an improvement to utilize the metal lid support of the modern phonograph to wind the spring automatically, as you raise and lower the lid after playing.

When a person stops to consider the enormous amount of cranking required to obtain pleasant music from the machine that talks, it will be seen the cranking is more in evidence than the music. The spring of the machine must be wound sufficiently each time to run the record around against the needle fast enough to reproduce the music record on the disc.

My idea is simply this: to do away with the unsightly crank altogether, and in place of it, to arrange the metal cover support so as to wind the spring half way as the lid is raised, to change the records, and then to wind it completely when the cover is



Why Not Make the Phonograph Lid in Its Raising and Falling Motion, Performed After Playing Each Record, Wind Up the Spring Motor Driving the Turn-Table?

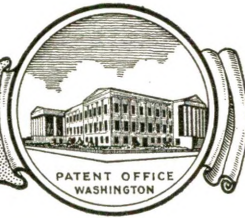

LATEST PATENTS

Pipe Mirror.

(No. 1,349,276. Issued to Harry J. Hays.)
Here is a clever adjustment to a pipe so that the smoker has abso-

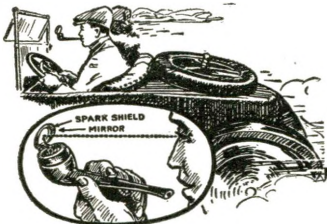

lute mental control of the smoking condition of the tobacco. In the daytime, he is able to do this by watching the smoke, but is denied this pleasure at night. The inventor, therefore, has placed a guard on the pipe, the surface of which is properly mirrored and so arranged that the glow of the burning tobacco will be conveyed to the eye of the user. At the same time, this guard prevents the wind from affecting the proper burning of the tobacco when automobiling or sailing a boat.

Foot Warmer.

(No. 1,348,506. Issued to Jose A. Mata.)

There are several new improvements in this foot warmer, which is provided primarily to be used in bed. It consists of a reflector or shade so adapted to reflect heat rays coming from the lamp and at the same time protects bed clothing from coming in direct contact with the heated lamp, preventing in this way spontaneous combustion of the bed

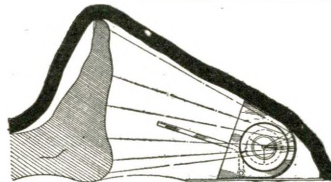

clothing. A pull-chain socket for the lamp is employed, the pull of which is connected to a sort of pedal so that the person lying in bed can, by pressing on the pedal, automatically turn the lamp on or off and thus regulate the heat coming from same.

Vaccine Injector.

(No. 1,347,622. Issued to Arthur E. Deininger.)

This invention will make it much easier to vaccinate many head of stock without necessitating the reloading of the instrument after each injection. It consists of a magazine wherein lie a plurality of vaccine tablets. When the spring plunger is pulled backward one tablet automatically drops into the ejector. Upon pulling the trigger after the needle has been pushed



under the animal's skin, a tablet is automatically shot into the proper position. In the handle of this vaccine injector a space is provided wherein a number of bottles of vaccine tablets may be kept. The instant that the magazine is empty an automatic device prevents resetting of the trigger, and the operator then knows that the pistol is empty and needs reloading.

Combination Salt and Pepper Shaker.

(No. 1,349,795. Issued to Otto M. Vogel.)

This is an improved combination shaker whereby it is not necessary to close one or the other of the apertures in order to allow the salt and pepper to be shaken out. In the head of the shaker are a number of baffle plates directed downward to the openings so as to form a grid wall. When the shaker is tipped toward one side, the vanes there allow the salt, for instance, to flow out freely, but the baffle plates in the adjacent compartment will be

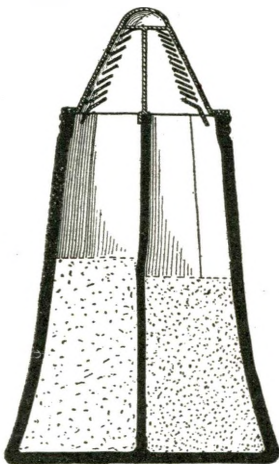

inclined upwardly thereby preventing the flow of pepper. The cap is detachable, so that the shaker can be filled, and ample provision has been made to prevent a mixture of the internal contents.

Self-Protecting Condenser.

(No. 1,350,010. Issued to William Dubilier.)

This patent, issued to the well-known inventor, resides in a condenser of such construction that, upon subjection to an abnormal electrical condition or pressure, it protects itself after puncture. The arrangement of the plates and dielectrics are the same as in the ordinary condenser, except that the

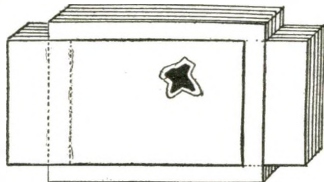

tinfoil is preferably in intimate contact with mica sheets and held there by insulating wax or some adhesive. The tinfoil has a thickness of about .00025 of an inch and the intervening mica sheet is about 3 mils in thickness. When the mica becomes punctured by an abnormal voltage stress, it causes a flow of current between two adjacent tinfoil sheets. The heat produced is sufficient to cause this tinfoil to melt or vaporize for a considerable margin around the aperture until a condition is reached which prevents the passage of electrical energy thru the aperture because of too large a distance between the two tinfoil plates.

Automatic Dam Gate.

(No. 1,344,043. Issued to Joel De Witt Justin.)

In this invention the patentee uses the water head pressure to automatically operate the dam gates

in a simple yet ingenious manner, and he makes the device adaptable to every kind of gate dam. The method of operation is quite simple. A valve is employed which moves

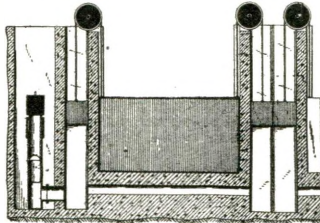

up and down in a sleeve and the projection of which either causes the water to operate directly on a mechanism to open the gate or closes a water port, allowing the gate in that way to close itself whenever the head has again been reduced to a proper level. Due to the counterweights on this valve, the device can be set for any predetermined waterhead or pressure, and when once set requires no further attention.

Current Motor.

(No. 1,346,285. Issued to Thomas H. Walker.)

Here is a rather clever device which can be used wherever there is a flow of water and it is desirable to pump the same to any great distance. The motor is so arranged that a series of paddle-buckets fall downward into the

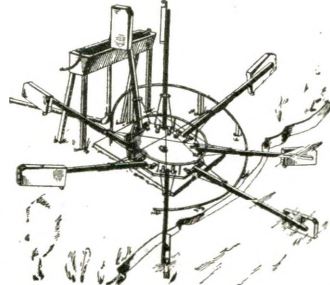

water where, due to the current, they are caused to rotate and at the same time automatically fill with water. Rising upward, they are lifted by a circular track which rises from the river or stream. Upon reaching their highest point an automatic trip opens the water outlet and allows the water from the paddle-bucket to flow through a trough, whence it is conveyed to the distant point by means of suitable piping arrangements.

Electric Darning Ball.

(No. 1,349,979. Issued to Lucinda Ritter.)

This is a rather clever improvement on grandmother's darning ball with the modern scientific touch to it. It consists of a tubular flash light casing, the glass lens of which is concave so that when the object to be darned is stretched across the end of the casing, a space will be provided for the ready passage of the needle. The light from the lamp shining thru the article materially facilitates the darning operation.

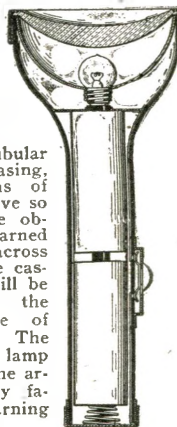

Detection of Low Frequency Impulses.

(No. 1,348,825. Issued to Reginald A. Fessenden.)

A clever device for the detection of low frequency impulses is the subject of this patent. It employs a commutator such as used for rectifying alternating currents, to which brushes are connected leading from an oscillator. Another set of brushes are connected to a Weston microammeter. Because of the toothed character of the commutator and the arrangement of the brushes each brush engages first one element and then the other, as can be seen from the diagram. When the oscillator is placed in the water and low frequency impulses approach it, a low frequency electric current is generated, particularly

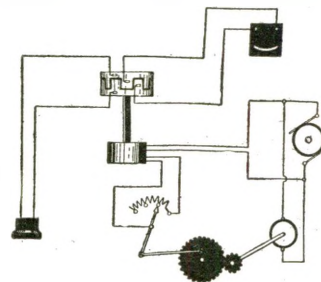

when a submarine is in or near the vicinity. The speed of the motor-driven commutator is then regulated by a field rheostat, which is adjusted to the motor thru a reducing gear which shifts the resistance of the rheostat slowly so as to vary the speed of the motor from its lowest range—about one turn in 10 seconds—to its maximum speed of 20 turns a second. At some one speed the revolution of the commutator will be such as to commutate the low frequency impulses generated by the submarine and give a rectified and easily readable indication on the microammeter.

Combined Generator and Pump.

(No. 1,349,397. Issued to Harry Randolph Van Deventer.)

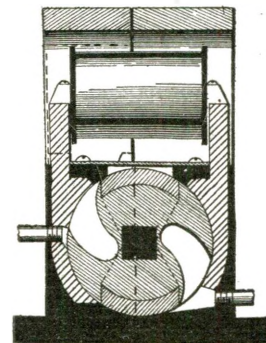

This machine has a rotor so designed that not alone will it generate a current, which when controlled by a suitable interrupter mechanism mounted in the casing will produce a suitable potential for the spark plugs of the gas motor, but also because of the peculiar construction of the rotor it will act as a centrifugal force pump, causing a circulation of oil which will lubricate both the generator and the engine. The generating coil is remote from the rotor of the pump but housed in the same casing. The invention promises to do away with the extra pumps now being applied to gas-driven vehicles.

Scientific Humor

Probably Sea-Sick.—"Father, what does a volcano do with its lava?" asked Teddy. "Give it up," replied the long suffering one. "That's right," said Teddy. —*Harry L. Moody.*

All the Same to Jupiter.—**PROFESSOR OF ASTRONOMY:** "How many moons has the planet Jupiter?" **STUDENT:** "Seven." **PROF:** "Enumerate them." **STUDENT:** "One, two, three, four, five, six, seven!"—*Harry L. Moody.*

En-Lightened.—**THIN:** "I've discovered that the heavy end of a match is the light end." **THICK:** "What do you mean?" **THIN:** "Strike one and you will see." —*J. Lawrence Bartley.*



Gone to Seeds.—Someone went into a seed store and asked the new clerk for some sweet potato seeds. He hunted all over the store and finally appealed to the boss, who explained that he was being made fun of. A few

days after a lady came in and asked for some bird-seed. "Aw, go on," grinned the clerk; "you can't fool me! Birds is hatched from eggs." —*Edward J. Rife.*

A Non-Conductor.—Superintendent to applicant for a position: "What is your name?" "Wood, sir." "You want to be appointed conductor?" "Yes, sir." "Can't take you, my man." "Why not?" "Because electrical experts say that wood is a poor conductor."—*No Name.*



Where Did He Expect to Wake Up?—A surgeon was performing an operation on a patient when a fire started in a warehouse across the street, illuminating the whole operating room. Having finished, the doctor said to the nurse: "I

think the patient is coming to; you had better pull down the shade. I don't want him to think that the operation hasn't been a success!"—*M. Goldberg.*

Same Here!—The scientific man was looking for information for his "facts and figures" notes. "How many people work in your office?" he asked the president of a large corporation. "Oh," said the president, "I should say, at a rough guess, about two-thirds of them." —*J. Kent Smith.*

She Didn't "Ring" Off!—"How about that telephone girl who married for love?" "The line's still busy." "What do you mean?" "She's doing the family washing." —*Elmer Edwards.*

FIRST PRIZE \$3.00

And the Milk, Too, "Turned"
—**Visitor:** "Don't you ever use electric milkers?"
Farmer: "Not any more. We never could remember to shut 'em off, and they turned the cows inside out."—*E. McAvoy.*

We Knew Something Was Loose!—"Who was the first bookkeeper?" "Can't imagine." "Why, Eve was the first bookkeeper, when she introduced the loose-leaf system." —*Harry Humbertson.*

"Henry" Should Get Wise to This!—Ad in *Journal of A. M. A.:* *Married man to milk and drive Ford. Write F. J. B., 721.*—*Vivian Gluson.*

How About Honeydew?—"When does grass become wet with dew?" asked the professor. "In dew time," was the answer from a pert freshman.—*No Name.*

ALL jokes accepted and published here are paid for at the rate of one dollar each, besides the first prize of three dollars for the best joke submitted each month. In the event that two people send in the same joke so as to "tie" for the prize, then the sum of three dollars in cash will be paid to each one.

Inventors! Wanted: Typewriter—Manicure Attachment.—"I'm sorry I asked the girl to clean the typewriter. She took fifteen minutes to clean the type and two hours to manicure her finger-nails afterwards."—*S. Fishman.*

From The Caledon Press.—For sale, cheap—small Evinrude Boat Motor; owner no further use.—Wire L76, this office.—*K. McLean,* Caledon, C. P., South Africa.

The Graft of These "Grafting" Jokes!—**First Boy:** "My father grafted an apple tree on a pinetree." **Second Boy:** "And what fruit does it bear?" **First Boy:** "Pineapples, of course." —*Ronald Jones.*

Thermal Efficiency.—"It is said that paper can be used efficiently in keeping people warm."

"That's so. I remember a note of mine that kept me in a sweat for thirty days!" —*Abe Jackson.*



A (W)Hopper.—Professor (discussing organic and inorganic kingdoms): "Now, if I should shut my eyes—so—and drop my head—so—and remain still you would say I was a clod. But I move, I leap. Then what do you call me?" **Bright Pupil:** "A Clodhopper, sir." —*No Name.*

Nor Indigestion!—**Jimmy:** "Father, why do we belch?" **Father:** "Because there is gas in our stomachs." **Jimmy:** "Hdh! Balloons have gas in them and they don't belch." **Father:** "That's because they have no stomach."—*Noah M. Thompson.*

Quite Plane.—**Smiles:** "To what ailment are aviators most susceptible?" **Miles:** "Oh—er—falling sickness, I suppose." **Smiles:** "No! Plane dropsy." —*H. D. Collins.*

Help Wanted!—An East India station-master had been cautioned to do nothing without instructions. That probably accounted for his sending the following message: "Superintendent's Office, Calcutta. "Tiger on platform eating conductor. Please wire instructions."—*D. Sheriff, Jr.*



Back-Fired.—When the clock struck "12" the other night father came to the head of the stairway and in a rather loud tone of voice said: "Young man, is your 'self starter' out of order tonight?" "It doesn't matter," retorted the young man, "as long as there's a crank in the house."—*Robert Friend.*

When East Is "Yeast."—Scientist, asking his daughter, who is taking cooking lessons: "Magnesia, why does the sun rise in the east?" **Magnesia,** thinking of her cooking: "Because yeast makes everything rise." —*Adolph F. Lonk.*

He Felt Like 30 Cents.—**Goat:** "Notice any change in me?" **X-ray:** "No; why?" **Goat:** "I just swallowed thirty cents." —*Carley Connor.*

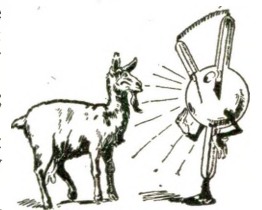

Must Have Been Joke Editor!—An editor at a dinner-table being asked if he would take some pudding, replied in a fit of abstraction: "Owing to lack of space, we are unable to find room for it at present."—*E. E. Newcomb.*

And Is Infinite.—Teacher to young miss—"Parse the word kiss." **Y. M.**—"This word is a noun, but is usually used as a conjunction. It is never declined, and more common than proper. It is not very singular, in that it is usually used in the plural. It agrees with me." —*H. F. Hyson.*

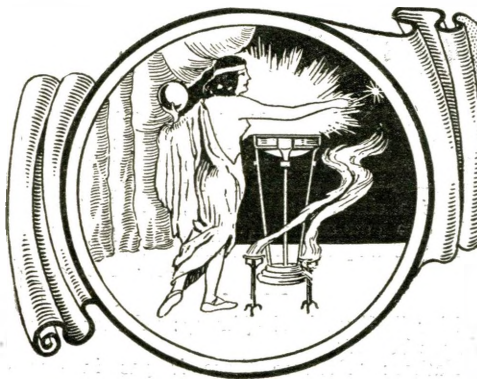

THE ORACLE

The "Oracle" is for the sole benefit of all electrical experimenters. Questions will be answered here for the benefit of all, but only matter of sufficient interest will be published. Rules under which questions will be answered:

1. Only three questions can be submitted to be answered.
2. Only one side of sheet to be written on; matter must be typewritten or else written in ink, no penciled matter considered.
3. Sketches, diagrams, etc., must be on separate sheets. Questions address to this department cannot be answered by mail free of charge.
4. If a quick answer is desired by mail, a nominal charge of 25 cents is made for each question. If the questions entail considerable research work or intricate calculations a special rate will be charged. Correspondents will be informed as to the fee before such questions are answered.

Automobile Storage Battery

(1068) Thomas H. McGuire, Long Beach, California, inquires of this Department:

Q. 1. If it is good practice to charge a storage battery frequently, say a little each day, instead of charging it fully all at one time.

A. 1. It has been the "Oracle" editor's experience in storage battery charging that it does no harm to keep the battery charged up to a fairly even rate by giving it frequent short charges, and that is the method frequently followed in general practice. Whenever the battery electrolyte falls to a certain minimum value, the battery is given a charge, and this may be two to three times weekly, more or less, depending upon the load put on to it. Occasionally, it is well to discharge a battery down to a fair minimum value, according to the best authorities, at least for lead plate cells. However, in support of your idea as to frequent charging, we have the modern ignition battery of large size, fitted in the motor-car of today, which is kept in a state of constant charge automatically, by means of an automatic charging cut-out or relay and a dynamo driven by the engine. Here the lead plate storage battery is charged constantly, or whenever it needs recharging, periodically.

We do not know who makes the small electric runabout used at the Panama Exhibition which you speak of, but undoubtedly you can obtain the address of a manufacturer of a similar vehicle, by communicating with the General Electric Co., Schenectady, N. Y. We do not see any reason why a small motor vehicle, if built light enough, could not be propelled by a "Smith" motor-wheel, as you state, and we have recently seen a light buckboard operated with a Smith motor-wheel, put behind the vehicle (the buckboard being fitted with four bicycle wheels), running along the country road at a speed of nearly twelve miles an hour and carrying two passengers.

Resistance for Given Voltage Drop

(1069) John L. Murphy, 507 Fifth Avenue, New York City, asks for method of figuring resistance to step down 110 volts D.C. to any potential desired.

A. 1. The data you request on voltage changes has not been thorough enough inasmuch as you did not give us the amperage you desire.

We are herewith giving you an example by means of which you can figure out the voltage obtained and the number of lamps necessary for any problem you may have. First, we will quote Ohm's law.

Suppose we desire 8 volts; but you have not told us the amperage you need. Let us assume this is to be 4 amperes. Then we use this formula in which E is equal to the voltage drop. R equals E divided by C . 110 V. minus 8 is equal to 102 , which is the residual voltage drop. Substituting in the above formula we get 102 divided by $4 = 25.5$, or the resistance in ohms necessary to be inserted to give us 8 volts and 4 amps. This means that four 1-amp. lamps joined in parallel may be inserted into the circuit. These lamps should give a resistance of 25.5. Four 100-watt lamps will answer very nicely for this purpose.

From the above data, we believe you can easily figure out the remaining voltage changes which you desire.

Data for Building 100-Volt, 25-Cycle, 1-KW Radio Transformer

(1070) Alfred A. Reiser, Buffalo, N. Y., inquires of the "Oracle":

Q. 1. Please give construction data for building a step-up high tension radio transformer suitable for use on 110-volt, 25-cycle alternating current circuit, as well as the dimensions of a suitable glass plate condenser to be connected across the secondary of this transformer.

A. 1. We give herewith the data you desire on the transformer in question. The laminated

or annealed sheet-iron core should measure 15 inches by $8\frac{1}{4}$ inches, outside dimensions; each leg of the rectangular closed core measuring 2% inches by 2% inches in section.

The primary winding should comprise 344 turns of No. 11 B. & S. gage, double cotton-covered magnet wire, wound in even layers along one of the longer legs of the core. Before winding on the primary coil, the iron core should be insulated with six layers of oiled linen. Taps may be brought out from each 100 turns, so as to give adjustability in controlling the transformer output.

The secondary coil is wound with No. 32 double cotton-covered, copper magnet wire, formed in pies or sections $\frac{1}{4}$ inch thick, each pie having a radial coil depth of about $2\frac{1}{2}$ inches; i.e., actual wire depth. The secondary comprises 38,664 turns in all, and by finding the mean radius and diameter of one turn, you can readily compute the total feet of wire and in turn the weight required, by consulting any electrical catalog or wire tables given in text-books.

The secondary potential with all primary turns cut in, will be 12,300 volts; with 300 primary turns the voltage will be 14,176 volts, and with but 200 primary turns cut in, the secondary po-

ARTICLES WANTED!!!

There is at the present time an excellent opportunity for writers of semi-technical, popular scientific articles and stories, as we are publishing more material of a popular nature each month. Stories should be as snappy as possible and should have well-rounded plots and characters. They should of course revolve around a scientific, electrical or radio focal point, to prove available for the columns of "Science and Invention." Good rates are paid on publication for stories accepted and published, and usually 2,500 to 3,000 words are sufficient. We also desire short write-ups with clear photographs on new scientific, electrical and radio subjects. Address all manuscripts to the Editor, "Science and Invention," 233 Fulton Street, New York City.

tential will be 21,265. The glass plate condenser suitable for connection across the secondary winding of this transformer should have a capacity of .15 microfarad. You will find full details, together with graphic curves showing the proper capacity for various voltage and kilowatt ratings and the area of glass plate and tin foil surfaces required, given in the book entitled "The How and Why of Radio Apparatus."

There is no use in giving the exact size of condenser here, as we do not know what size glass you want to use, nor what kind of glass, the dielectric constant varying for different grades of glass. The approximate capacity in microfarads for unit areas of common glass are as follows:

For each 1 square inch of $\frac{1}{8}$ inch thickness of glass coated on both sides with foil or other metal charging leaves, the capacity is .00000562774 mf.

The unit capacity per square inch of 1/16-inch glass, coated on both sides with metal charging leaves, is .00001125548.

Hughes' Induction Balance for Locating Ore

(1071) James Conroy, of Troy, N. Y., asks: Q. 1. For some specific data on building the coils on the Hughes' induction balance described in the June, 1920, issue of this journal by Victor H. Todd.

A. 1. In reply to your query we would advise that the two large coils mentioned have 100 turns

of No. 14 B. & S. gage enameled copper wire and the transformer mentioned is similar to an induction coil, with a primary wound on an iron wire core about 3 inches long and $\frac{1}{2}$ inch in diameter. The primary consists of one layer of No. 14 B. & S. gage enameled copper wire, wound with two wires in parallel. The secondary has about 10,000 turns of No. 36 B. & S. gage enameled copper wire. The inductor balances comprised 12 turns of No. 14 copper wire, wound about $\frac{1}{4}$ inch in diameter.

The rheostat contains about 10 inches of No. 14 B. & S. gage German silver wire. The battery is of four dry cells, and 1,000-ohm telephone receivers were used.

Magnitude of Tesla High Frequency Currents

(1072) James T. Wilson, Jr., Brooklyn, N. Y., writes this journal:

Q. 1. About an apparent error in the "Wireless Course," by Gernsback, Lescarboua and Secor.

A. 1. With reference to the error which you cite as appearing in the Electro Importing Co.'s "Wireless Course."

In the first place, the "Wireless Course" is being rewritten in considerable detail so as to include some valuable and timely material on vacuum tubes.

We note what you have to say concerning the statement on page 135 of the "Wireless Course," concerning the giant Tesla transformer, and the coils which Dr. Tesla used in his famous Colorado experiments, and in which you doubt that the discharge was of the magnitude of 800 amperes, at a potential of a billion volts or more.

We cannot vouch for the exact figures of this discharge, but you can figure it out for yourself as to the approximate potential and the amperage, when we tell you that Dr. Tesla's records and photographs which we have had the pleasure of seeing, show he absolutely produced tremendous discharges, the like of which have never been duplicated. They measure 100 feet in length in some instances, and the various sparks have diameters ranging from a few inches up to a foot or more.

Where most of the people who try to figure out the Tesla experiments mathematically err lies in not allowing for the great difference between the actual and the apparent watts, or in other words, they forget the low power factor, which the editor has often discussed with Dr. Tesla; and further, the fact that these tremendous energy rates are dependent upon or based upon a very short time interval.

Simply explained, the theory of the apparatus and the tremendous discharges obtained, is as follows:

If you have 100 kilowatts in the form of low frequency A. C., and you use this energy for a period of one hour, then you would call the amount of energy expended 100 kilowatt-hours; but if you were able to charge this energy into huge condensers and then discharge it in less than a minute, or 1/60th of an hour, then the rate of discharge would be 60 times 100 kilowatts, or 6,000 kilowatts. Another thing in regard to the amperes of current passing thru a high frequency circuit, such as a Tesla circuit, is that the current does not act in the same way as a low frequency, 60-cycle A. C., or direct current, and is not computed in any such manner.

To prove this point in a simple way, take, for instance, the fact that if you apply sufficient potential to the human body, less than 1/10 ampere passing thru the heart causes death invariably. But Tesla, and thousands of others, have readily past tremendous currents thru and over the body with a current registering many more amperes than anyone would ever believe possible—in fact, to such an extent that whole banks of incandescent lamps have been lighted up by the current after it had past thru the body.

In other words, we enter into an entirely new realm of electrical calculation when figuring on Tesla currents and circuits.

Send No Money

Silvertone

Let Us Send You This SILVERTONE Phonograph for Two Weeks' Trial in Your Home Without Expense to You

WE WANT you to try this beautiful Model K Special SILVERTONE Phonograph in your own home for two weeks without a cent of expense and without obligating you to buy if you are not fully satisfied with the instrument.

Fill in the order blank and mail it to Sears, Roebuck and Co. today. We will ship the phonograph on two weeks' trial. You take absolutely no risk, nor do you obligate yourself in any way by taking the SILVERTONE on trial. All we ask you to do is to give the phonograph a thorough test. Examine its mechanical features, cabinet work, workmanship and finish. Try it with any disc record you desire, and note its beauty of tone and fidelity of reproduction. Give it every test necessary to prove the truth of our claims for it. And then compare the price of the SILVERTONE with that of any other phonograph of the same size, beauty and musical excellence.

If, at the end of two weeks' trial, you are not fully satisfied with the SILVERTONE, if you do not believe that it is in every way the equal of any phonograph on the market selling at prices from 25 to 50 per cent higher than the SILVERTONE, simply notify us and we will take away the phonograph at our own expense and will refund any transportation and cartage charges you have paid. The two weeks' test will not have cost you one cent, nor placed you under any obligation.

Play as You Pay—Very Easy Terms

If, after two weeks' trial, you are fully satisfied with the SILVERTONE and desire to keep it, simply send us the first monthly payment of \$4.00 and then the same amount each month until the total is paid.

Compare our terms with those offered on any other phonograph of the same high quality. The small monthly payment required makes it easy for you to own a really fine instrument without incurring a heavy financial burden.

This Liberal Selling Plan Is the Best Guarantee of SILVERTONE Quality

We know that the SILVERTONE Phonograph is right in every respect—mechanically, musically and in design and finish. That is why we can offer them on this liberal no money down trial basis. We know that when you get a SILVERTONE Phonograph in your home for two weeks' trial you will be convinced of its high quality and will agree with us that it is the best phonograph on the market at anywhere near the same price. We have sold over 330,000 SILVERTONE Phonographs, and the unanimous praise of their owners is the most convincing proof of SILVERTONE quality.

Plays All Disc Records

The SILVERTONE convertible tone arm is so constructed that it permits the playing of any make of disc record, either vertical or lateral cut. It is almost as easy to adjust the reproducer for different types of records as it is to change needles.

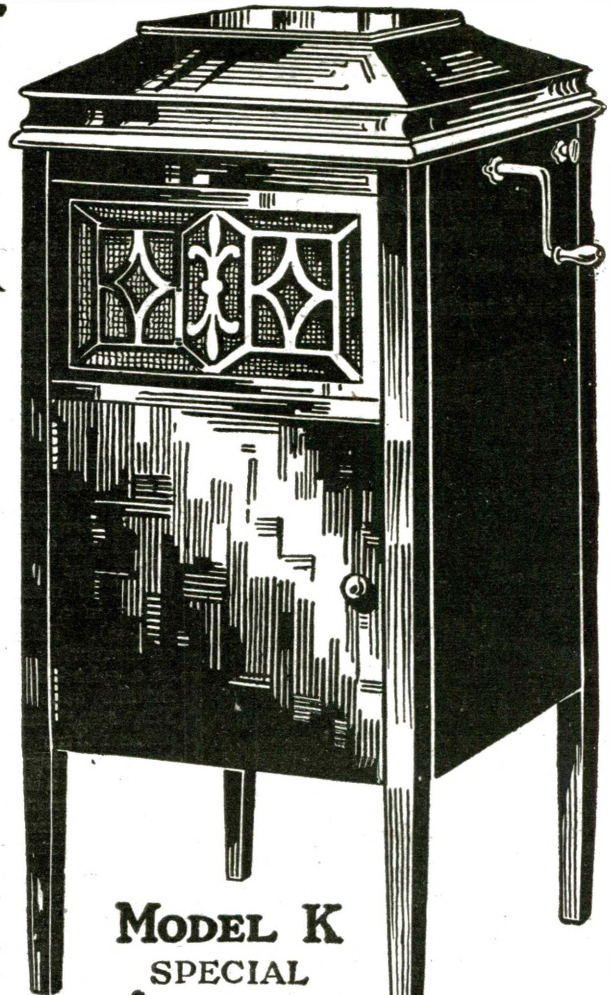

MODEL K SPECIAL

\$4.00 Price
A Month **\$79.00**
Quarter Sawn Fumed Oak

This beautiful cabinet is made of genuine quarter sawed oak in the popular dull fumed finish. The design is simple, yet graceful and dignified. It is 42 1/4 inches high, 21 1/2 inches deep and 18 1/4 inches wide, a size admirably adapted to the average living room. All visible metal parts are heavily nickel plated and polished. An assortment of needles is included. Net weight, ready to play, about 66 pounds.

Sears, Roebuck and Co.

Chicago · Philadelphia · Seattle · Dallas

MAIL YOUR ORDER TO THE NEAREST OF OUR FOUR STORES

Sears, Roebuck and Co.

82F92

Date _____ 192__

You may ship me the Model K Special SILVERTONE for two weeks' trial. If after two weeks' trial I decide to keep and use the instrument, I will send \$4.00 as first payment for the phonograph and pay the balance at the rate of \$4.00 each month, until paid in full; then the SILVERTONE becomes my property. Should I decide after two weeks' trial that the SILVERTONE is not satisfactory, I will notify you and you are to give me instructions so that I may send it back at your expense, and you are also to return any amount I paid, including transportation charges. I have always been faithful in paying my obligations and am making this statement for the purpose of inducing you to grant me these terms, and I give you my pledge that you may feel safe in trusting me to pay as agreed.

Sign Here (Sign your name here plainly and carefully. If under age, some member of your family who is of age and responsible should sign this order with you.)

R. F. D. _____ Box _____ Street _____
No. _____ No. _____ and No. _____

Postoffice _____ County _____ State _____

Shipping Point _____ County _____ State _____

I have been located in this town since _____ If less than five years, give former address _____ Do you wish shipment made by express or freight? _____ (State which)

Please give name of HEAD OF HOUSEHOLD to prevent mistakes and simplify the keeping of our records. My business, profession or occupation is _____
Name of HEAD OF HOUSEHOLD _____

(Please give Names of TWO References.) References:
Name _____ Address _____ Business or Occupation _____

Give it to Him for CHRISTMAS

It will make him
an Expert Wireman
and he can Earn \$75 a Week
Don't wait—Order today

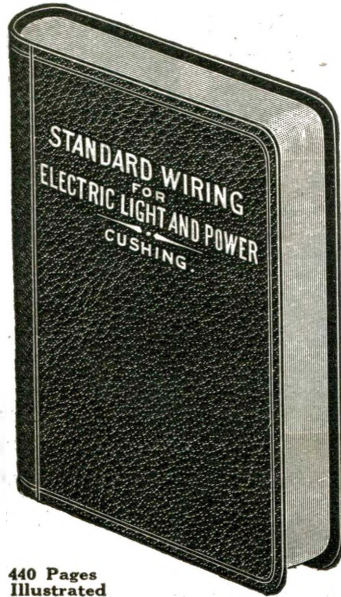

440 Pages
Illustrated

The National Authority for 26 Years
The only complete and
accurate book on wiring

CONTENTS

The National Electrical Code, with all its new rules, is explained and illustrated. 52 of the latest and simplest tables which show, at a glance, just what size of wire is needed for any kind and size of lighting, motor or heating installation, for any voltage, current and drop desired for any system, Direct Current, Alternating Current, single, two or three-phase. The latest Code Rules on grounding required on all work.

SPECIAL NEW CHAPTERS

How to install and operate generators, motors, storage batteries and every kind of wiring device with diagrams of connections. Illumination, House Wiring, Garage Wiring, Theatre Wiring, Moving Picture House Wiring, Sign Wiring, Marine Wiring, Electric Range and Heater Wiring, Watt-Hour Meter Wiring and complete chapters on inside and outside wiring for every system from a central station to the smallest cottage. 250 Electrical Units and their Definitions and Equivalents. The latest lamp data. Proper symbols to use to indicate outlets, etc., etc. Also a complete directory of the leading manufacturers of officially approved apparatus and supplies necessary for any kind of installation.

Every inspector in this country will approve any wiring job if done in accordance with the simple rules in Standard Wiring.

Leather Cover. Pocket Size. Gilt Edges.
Sent Postpaid on Receipt of \$3.00.

H. C. CUSHING, Jr.
8 West 40th Street New York

Einstein Theory and the Fourth Dimension

By H. Gernsback

(Continued from page 840)

think that the earth contracts just the same due to its speed. But what is a speed of 69,000 miles an hour (or 101,200 feet per second) compared to the speed of light moving at the rate of 186,000 miles per second! As far as the speed of light is concerned, the orbital velocity of the earth is insignificant.

Coming back to the contraction theory in the Michelson-Morley experiment, it becomes apparent that if the earth contracts a certain amount, not only the latter but the measuring instruments as well would shrink in the same proportion, which would account for the fact that we cannot detect the difference in size which we hoped to measure. It is as if we were living in a world of curved mirrors (see Fig. 3). Take a man with divided rules or measuring sticks and place him in front of a cylindro-convex mirror. He naturally shrinks and so do his measuring sticks. The same man standing in front of a plane mirror will be reflected along with his measuring sticks in his true proportions; yet a man standing in front of a convex mirror, with axis vertical, will have his yard-stick contracted in the opposite way analogous to the man standing in front of the other convex mirror. Every measurement of this man would be wrong, and yet in a way the measure would be correct! This seems hard to understand, but a study of Fig. 3 will make this plain.

Once we admit the Lorentz-Fitzgerald contraction theory, we must also accept another equally astonishing one, and that is what is called the theory of local time. Take two clocks running together in perfect accord. If one of them is placed upon a moving platform, or if both of them are placed upon such a moving platform, their times will not be the same any longer but will vary in order to vindicate the Michelson-Morley experiment. Thus while the clock which moves keeps perfect time, yet the seconds it ticks off are longer than those of the clock at rest. We have thus two different sorts of time! So far the Lorentz-Fitzgerald contraction theory has not been confirmed by experiment nor has the local time experiment been confirmed. It is doubtful whether either will ever be actually proven by experiment.

How Are the Airplanes Moving?

We now come to another aspect of relativity. Consider Fig. 4. Here we have two airplanes passing one another, each moving at the rate of 200 miles per hour. This gives us a relative motion of 400 miles per hour considering both of them. We also find the astonishing result first laid down by Einstein, viz., that it is impossible for an observer on a moving body to ascertain the speed of the other moving body by any means or by any instruments known to science.

For the two airplanes, moving at a relative motion of 400 miles per hour, are moving in many other directions as far as the earth, or rather the universe, is concerned. For while the airplanes are moving at a certain speed, the earth's atmosphere, which carries the planes, is moving at a different speed. Again the earth moves itself. This is made more apparent by studying Fig. 6. We first have the axial rotation of the earth from west to east at a speed of 1,039 miles an hour. But, while the earth is spinning like a top, it also moves forward in its orbit around the sun (see illustration) at a speed of 65,533 miles an hour; but this

is not all. We still have the cosmic drift as our picture clearly shows, whereby the earth as well as all the other planets and the sun itself are carried forward in space in a sort of huge spiral. In other words, the earth is moving in three directions all at once. First, axial rotation, second orbital motion, third cosmic drift.

But let us revert to Fig. 4 and our aviators. It now seems hopeless to figure out not only at what speed they are really flying, but in which direction they are going. (Continued on page 892)

2 FLANNEL SHIRTS \$3.69

Direct from Factory Send No Money



Two wonderful Susquehanna Broadcloth Flannel Shirts only \$3.69. Direct from factory. No Middleman's profits. Would cost \$8 or more elsewhere. Perfectly tailored. Cut extra full. Comfortable fitting. Winter weight. Soft turn-down collar. Two extra strong, large pockets. Double stitched throughout. Thoroughly shrunken. For work or semi-dress. An amazing bargain. Send no money. Pay postman only \$3.69 plus postage after arrival. Then try them on. If not pleased, return at our expense; your money returned at once. Order by number FS359. State size. Specify gray or blue. Only two shirts to a customer on this special offer.

WAREWELL COMPANY Dept. FS359
Philadelphia, Pa.

The Key to Success
Stop forgetting
Make Your Mind a File—Not a Pile

The Key to Success is the ability to remember. I can make your mind an infallible classified index from which you can instantly select thoughts, facts, figures, names, faces. Enables you to concentrate, develop self-control, overcome bashfulness, fear, shyness, address an audience. Easy. 20 years' experience developing memories of thousands.

Write Today for free booklet, "How to Remember" and Copy-righted Memory Test, and how to secure Free my \$3.00 book. "How to Speak in Public."

DICKSON MEMORY SCHOOL
Dept. 101 1041 Chicago Av. Evanston, Ill.

Study Microbiology, Bacteriology and Sanitary Science. Home Study and Residential Courses, including Parasitology, Serology and Wasserman test. Interesting and Profitable Professions. We teach the above Sciences quickly and thoroughly, as well as Urinalysis, Blood Analysis, Detection of Poisons, Blood Stains, etc. Diplomas and Degrees granted. Many positions open. Write for Free Prospectus.

PHYSICIAN'S AND SURGEON'S COLLEGE OF MICROBIOLOGY
546 Garfield Ave. Dept. 3Z Chicago

CLIP THAT COUPON



Are You Technically Trained? If Not, Clip That Coupon
 Chicago Technical College, 1245 Chicago "Tech" Bldg., Chicago, Illinois

Without obligation on my part, please send free and postpaid, instructions on how I can become an expert in subject marked below:

- | | | | |
|--------------------------|------------------------|--------------------------|-------------------------|
| <input type="checkbox"/> | Architectural Drafting | <input type="checkbox"/> | Auto. Engineering |
| <input type="checkbox"/> | Machine Drafting | <input type="checkbox"/> | Aero. Engineering |
| <input type="checkbox"/> | Electrical Drafting | <input type="checkbox"/> | Gas Engines |
| <input type="checkbox"/> | Structural Drafting | <input type="checkbox"/> | Plan Reading—Buildings |
| <input type="checkbox"/> | Sheet Metal Drafting | <input type="checkbox"/> | Estimating—Buildings |
| <input type="checkbox"/> | Topographic Drafting | <input type="checkbox"/> | Plan Reading—Machinery |
| <input type="checkbox"/> | Surveying | <input type="checkbox"/> | Plumbing—Estimating |
| <input type="checkbox"/> | Designing | <input type="checkbox"/> | Heating and Ventilating |
| <input type="checkbox"/> | Contracting—Buildings | <input type="checkbox"/> | Steam Engineering |

Name

Address

Post Office..... State.....

College or Home Study. State which.....

Free Lesson when inquiry is for Draftsmanship or Plain Reading.

Learn At Draftsmanship Home



THE employer today knows the value of technical knowledge. He surrounds himself with experts—not merely good mechanics but technically trained practical men. He is ready and willing to pay their price, for he wants expert advice and service.

Get the facts about the Chicago "Tech" Course in Draftsmanship (or any of the other big paying professions listed on the coupon). You can master all these courses quickly by spare time study at home. Draftsmen earn bigger salaries than ever before, because trained men are scarce. Hundreds of big paying jobs waiting and not enough experts to go around.

Constant and Growing Demand for Trained Draftsmen

Proficient men are needed badly in the drafting departments of big manufacturers, architects, railroads, electrical plants, etc. Many experts earn \$60 to \$150 weekly.

This is your big chance. See how well qualified you are before

you spend one penny. Send for the Free Test Lesson described below. Also learn how and why a Chicago "Tech" course will make you the man chosen from among many. Clip and mail the coupon—now.

Experts Teach You Their Practical Methods

The Chicago "Tech" method trains you under experts who equip you for important positions in the shortest practicable time. You learn exactly the methods which they use in their own practical work. They give you the training that ranks you with draftsmen of long experience—that is required of men who aim to hold executive positions. Why be content just to take orders when

you have it in you to *Give* orders, once your training gives you the confidence to assume charge of the men who do the actual work? The practical knowledge you get from Chicago "Tech" experts fits you to step right out and earn a big salary.



Choice of 18 Courses that Will Increase Your Salary

There is no better way to spend your leisure hours than in fitting yourself for the big jobs above you. If you want to master quickly any other technical study, make your choice from the wide range of big paying professions listed on the coupon. If you cannot come to the College, you will get the same course—the *same thorough individual instruction from the same experts by mail*. It does not matter where you live. Your lessons are directed and every exercise read and corrected by experts who make every point clear. You progress as quickly as your lessons show that you have mastered their subjects. With the practical knowledge you have gained from a Chicago "Tech" course, an employer need not take long to

decide. You will be the man chosen—the man pushed ahead—because you will not only *know how to do things* but *why they should be done*. And no matter which course you decide on, you learn just the things you need know from practical men who give you the benefit of their long training. They fit you to start at a good salary and to win rapid promotion.

Send **FREE** Test for **FREE** Lesson

Shows you how well qualified you are for draftsmanship. Other schools ask you to enroll and send money first. We send the free lesson first. Read it—practice the exercises—no obligation. Decide for yourself whether you want to take the course or not.

FREE OUTFIT

With our home study course is included a complete set of high-grade instruments, drawing board, T-square, etc. Same as leading draftsmen use. Credit given if you already have an outfit.

Act Today Decide right now—get the facts. Find out how hundreds of ambitious men have prepared themselves for high positions merely by using their spare time for study. This information costs you nothing. Just put X in the square on coupon opposite the course you want to know about. Then clip, sign and mail the coupon today.

Chicago Technical College

1245 Chicago "Tech" Bldg.
 Chicago, Illinois

CLIP THE COUPON NOW



Surprise the Best Boxer

JUST imagine how tickled you'll be, the next time your pals have a boxing bout, to meet that chap who thinks he "knows it all" and box rings around him—show him blows he never knew existed, hit him wherever and whenever you please, and guard, duck and side-step so cleverly that he can't even land on you! This is easy when a fellow has learned the methods used by professionals.

Marshall Stillman, the pupil of the famous Professor Mike Donovan, is teaching boxing to hundreds of live young men—and to men as old as 60—right in their own home. Over 10,000 pupils have studied his old course and think it wonderful. His new course is better still—and bigger. It teaches boxing, jiu jitsu, wrestling and physical development.

The system is unique. Lessons are practiced before a mirror, and you start with such simple movements as reaching out your hand for a coin, the breast stroke in swimming, etc. Step by step you are led into striking heavy blows, guarding, ducking, feinting, side-stepping, just as if you had a real opponent before you. You are taught every good blow used in the ring, when to use it, where to land it, and how to guard against your opponent's blows.

To develop your speed, you practise three rounds of shadow boxing daily, using such scientific blows as the Mike Donovan Double, the Jack Dempsey Triple, the Bennie Leonard Triple, the Fitzsimmons Shift, etc. Then comes instruction in Jiu Jitsu—how to disarm an opponent with pistol, dagger or club, how to stop a kick, how to break a strangle hold on your throat, etc. The Wrestling Lessons include the Gotch Toe Hold, the Stecher Scissor Hold, etc.

The Health Exercises are designed to build strength and endurance—not simply muscle—and include the Colon Exercise, a remedy for constipation, and Synthetic Breathing, a great lung developer and aid in curing nervousness.

Other features are a history of 69 great prize fighters, with their pictures (tells inside stories not generally known, their pet blows, etc.), lessons in Mass Boxing, an article on training, and a copy of the new International Sporting Club's Boxing Rules.

There are 246 illustrations—some course, eh?

SENT FREE ON APPROVAL

We send the entire course (6 books) on approval. Order now, and pay for it on the 15th of next month (\$5 in the United States, \$6 in Canada, \$7 in foreign countries). If you don't like the course, return it in 10 days, and that will end the matter. But you'll keep it all right! Mail the coupon now to the Marshall Stillman Association, Suite E-112, 461 Fourth Avenue, New York.

COUPON

MARSHALL STILLMAN ASSOCIATION
Suite E-112, 461 Fourth Avenue, New York

You may send me your complete course in Boxing and Self-Defense, including extra instruction described above. I give you my pledge that you may feel safe in trusting me as agreed, and that I will pay \$5 (\$6 in Canada, \$7 in foreign countries) for the course on the 15th of next month or return it in 10 days after I receive it.

Name.....
Address.....



WANTED—Railway Mail Clerks

\$1600 to \$2300 year

Hundreds needed. Examinations Coming Everywhere.

FRANKLIN INSTITUTE
Dept. E181 Rochester, N. Y.
Sir: Send me without charge (1) sample of Railway Mail Clerk Examination questions; (2) list of government jobs open to men and women and (3) free book describing them.
Name.....
Address.....

Popular Astronomy

By ISABEL M. LEWIS, M.A.

(Continued from page 861)

would have had a much greater vertical range than they have at present and the sedimentary deposits along the early coastal lines would have been much coarser than they are today. There is absolutely no geological evidence to this effect.

So both the geological evidence and the development of the tidal theory upon the assumption that the earth is highly elastic, instead of viscous, lead to one and the same conclusion—that the earth's rotational period since the formation of its surface crust has never been appreciably greater than it is at present; and for the moon to have separated thru centrifugal force from a fully formed earth and to have revolved close to the earth's surface during the earliest period of the earth's history would be contrary to the known facts and a physical impossibility.

The theory that the moon was once an integral part of the earth has had many adherents and has been put forward by many of the world's most greatest scientists, and from the foregoing facts and considerations it would seem that this is indeed a physical possibility.

One of the reasons why this would seem so is the fact, as shown clearly in the tabulated data given below, that when the earth rotates in a time-period sufficiently short to

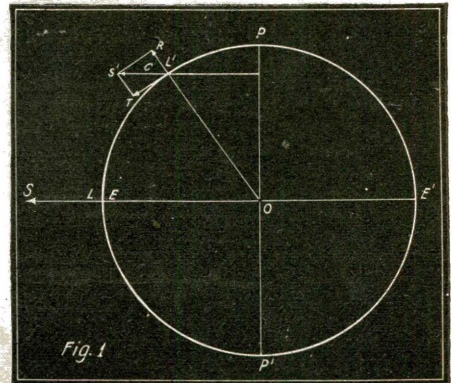

The Circle Represents the Section of the Earth With Axis PP' and Equator EE'. The Arrow SL Represents the Centrifugal Force at the Equator. Nearer the Pole S'L' Represents the Diminished Centrifugal Force and of This Only a Part, the Radial Component RL', Operates to Reduce the Weight of Any Object.

increase its periferal velocity at the equator to the point where centrifugal force would overcome gravitation, then practically total disintegration of the earth itself would undoubtedly occur.

SHAPE OF THE EARTH AND DISTRIBUTION OF SURFACE GRAVITY FOR DIFFERENT PERIODS OF ROTATION.

Rotation Period hours	Equatorial Diameter miles	Polar Diameter miles	Polar Flattening miles	Polar Weight (of man weighing 150 lbs. at Equator) at 24 hours rotational speed lbs.	Equatorial Weight lbs.	Centrifugal Force (at Equator) dynes
24.0	3963	3950	13.3	150 3/4	150	3.4
14.0	3972	3932	40	151	149	8.0
7.5	4005	3867	138	156	144	34.9
4.5	4090	3680	410	156	133	99.6
4.0	4124	3609	515	157	128	124.5
1.41*	****	****	***	***	0	981.4

*Note:—For this rotational period a man would weigh nothing at the equator but considerably more than 150 lbs. at the poles. For higher velocities objects in equatorial belt would leave the earth's surface, and the earth would be in such unstable equilibrium that it would disintegrate.

Einstein Theory and the Fourth Dimension

(Continued from page 890)

You see everything is relative in this world. To make the latter clear, consider Fig. 5. When you take a train from New York to San Francisco you have every reason to believe that you are moving from east to west at the speed of the train, which let us say is 60 miles an hour. You are quite certain you are going west. Fig. 5 shows that you do nothing of the sort. You are going due east, because the earth revolves from west to east, and, while you move west at the rate of 60 miles an hour, you are really going east due to the rotation of the earth at a speed far exceeding many times 60 miles an hour. In other words, while you think you are going west at the rate of 60 miles an hour, you are really going east at nearly ten times as great a speed. This is another instance of relativity.

The Fourth Dimension.

This brings us to the fourth dimension. As we have just seen everything is moving. Nothing really stands still. Anything that we can imagine really moves, whether it is stationary on earth or anywhere in the universe. Heretofore we said that an object, let us say a cube, had length, width and depth. This is our classical three dimensional body, but in Einstein's world we must now add another dimension, the

fourth dimension, viz., TIME-SPEED (see Fig. 2). Here we have first the so-called stationary body (altho it really is not stationary at all). If we move this body, which let us say is a brick, at a speed of about 100,000 miles per second, we find that it contracts somewhat in the order as shown in the illustration. While moving at a speed of about 175,000 miles per second—in other words, almost as fast as light itself—we find that our brick has contracted sufficiently to almost form a cube. Thus our rectangular brick, while at rest, shortens or contracts in the direction of its axis when speeding at a tremendous speed. Inasmuch as this contraction or shortening only takes place while the brick speeds on, and because you cannot have speed without time, the fourth dimension of this brick is now termed time-speed. This is an astonishing result, but it probably comes nearer the truth of what the fourth dimension really is than any of the older theories in vogue heretofore. It is rather difficult for us to comprehend just what this fourth of the four dimensions, viz., length, width, depth, time-speed, really means because on earth, as far as we ourselves are concerned, there are no such speeds as 175,000 miles per second, or even 100,000 miles. We simply cannot comprehend such speeds.

(Continued on page 897)

Hurry Call=

The Price of the CROFT LIBRARY of PRACTICAL ELECTRICITY must go up

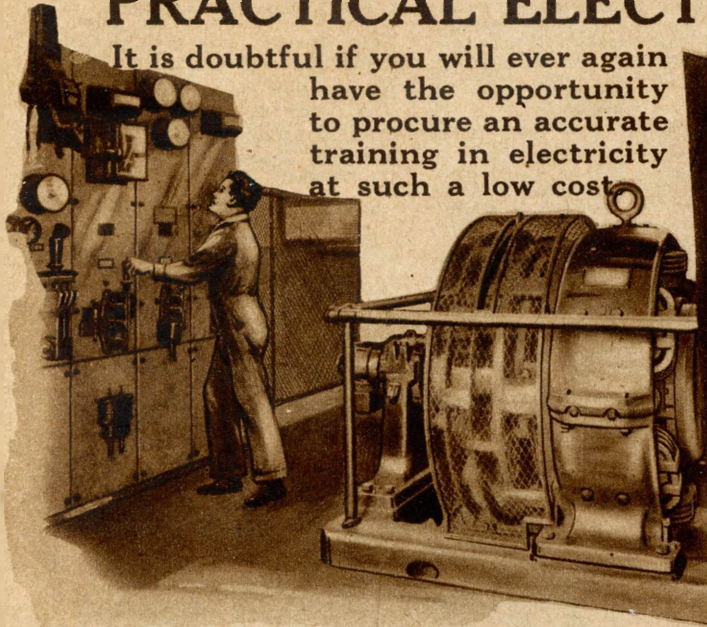

It is doubtful if you will ever again have the opportunity to procure an accurate training in electricity at such a low cost.



ANYONE acquainted with the paper situation in this country understands the absolute necessity for increasing prices of all printed literature. While other commodities have doubled and trebled in price during the past few years, technical books have remained nearly stationary, and as a result hundreds of publishers have been compelled to close up shop.

NOT ONE CENT IN ADVANCE

8 flexible pocket books—over 2,000 illustrations, the best illustrated and most easily understood electrical library in existence.

There is plain evidence before us every day that the opportunities in the world of electricity are increasing constantly. Opportunities have always been abundant, but today there are more high-paying positions open than at any time in the history of electricity—even during the high production period of the war. The educational institutions simply cannot train men fast enough, because new uses are being found for electricity every day, and the progress of the world more and more depends upon it.

Read This—
 Electricity, from the simplest principles to complete and economical operation of a central station.
 Motors, generators, armatures, commutators, transformers, circuits, currents, switchboards, distribution systems.
 Electrical machinery of every type. Installation, operation and repair.
 Wiring for light and power. How to do it mechanically perfect in accordance with the National Electrical Code.
 Wiring of finishing buildings. Underwriters' and municipal requirements. How to do the complete job, from estimating it to completion.
 Illumination in its every phase. The latest and most improved methods of lighting. Lamps and lighting effects.
 A complete course in mathematics as applied to work. A course which refreshes your mind, and gives you mastery of all the shortcuts in figuring.
 Electrical practice complete. Electrical practice as experts know it. Electrical practice by experts.

Terrell Croft is doing his share in teaching men the correct principles of electrical practice. He knows the game from experience. He has poured out all his secrets, all the short cuts, all the time savers, in language that even the common school boy can easily grasp. Yet the text is so scientifically correct that thousands of the highest paid electrical engineers are using the books as references.

The Croft Library of Practical Electricity is inexpensive, and still it contains more real practical working data than is probably embodied in any existing course, even those costing hundreds of dollars.

You will surely want the Croft methods some day, and by ordering now you will effect a very considerable saving.

Fill out the coupon today, now, and get your set at the old price.

FREE EXAMINATION COUPON

McGraw-Hill Book Co., Inc.
 239 West 39th Street, New York
 Publishers of Books for Engineers Since 1876

McGraw-Hill Book Co., Inc.
 239 West 39th St., New York.

Gentlemen: Please send me the Library of Practical Electricity (shipping charges prepaid), for 10 days' free examination. If satisfactory, I will remit \$2 in ten days and \$3 per month until \$20 has been paid. If not wanted, I will write you for return shipping instructions. (Price subject to advance.)

Name

Home Address

City and State

Where Employed

Occupation

Chemical Laboratory

We present herewith to our friends our E. I. Co. Chemical Laboratory which contains real chemicals and apparatus to perform real chemical experiments. This outfit is not a toy, put up merely to amuse, but a practical laboratory set, with all the chemicals, apparatus and reagents necessary to perform real work and to teach the beginner all the secrets of inorganic chemistry. With this outfit we give free a book containing a *Treatise in Elementary Chemistry*, useful data and recipes, and 100 instructive and amusing experiments.

\$6⁰⁰

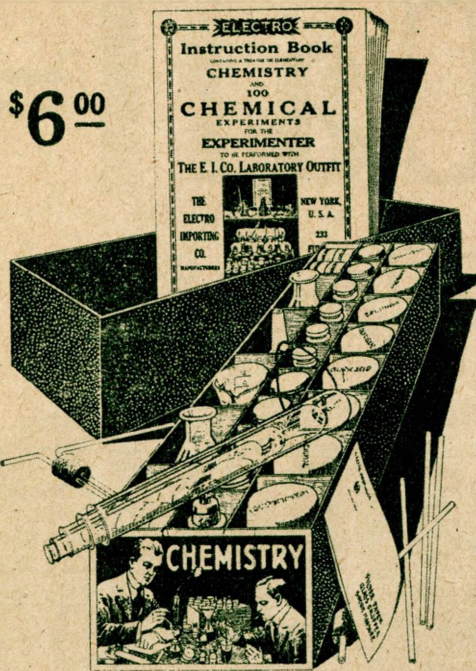

No. 4889

DESCRIPTION OF THE OUTFIT:

The outfit consists of forty-four (44) Chemicals all C. P. (chemical pure) put up in appropriate wooden boxes, glass bottles, and hermetically closed jars. The acids are put up in glass bottles, with ground-in glass stoppers and there is a sufficient quantity of chemicals supplied (mostly one to two ounces) enough to make dozens of experiments with each.

The apparatus furnished are all of the best obtainable make and of standard laboratory size and shape. 17 pieces of apparatus furnished with this outfit.

The instruction book is a real Chemistry Course for the Beginner. Some of the Contents are: Division of Matter: This is a Treatise on Elementary Chemistry and deals with the theory of the Elements, Molecules and Atoms, etc. Chemical Nomenclature: This explains in simple language the derivation of the chemical names of the Elements and their compounds. There is a chapter on Laboratory Operations; Glass Working; First Aid; Fire Extinguishers; Experimenters' Aphorisms, etc.

A good part of the book is devoted to Weights and Measures. The Metric System, the English System and the U. S. System are fully explained.

The following tables are furnished: Symbols and Atomic weights of the Elements; Measures of Weights, Volume, Capacity and Length; Per Cent solutions; Conversion of Measure expressed in parts; Poisons and their antidotes; Technical and common name of chemical substances; Formulas for Cleaning various substances, etc., etc.

Among the 100 Experiments are:

How to make chemical tricks; How to make invisible and magic inks; How to test flour; How to test soil; How to Make Chlorine Gas and Smoke (German War Gas); How to bleach cloth and flowers. How to produce Oxygen and Hydrogen; How to make Chemical Colors; How to test Acids and Alkalies and hundreds of interesting hints and formulas.

Price \$6.00. Shipping Weight 10 lbs. (Can be shipped by Express only.) Immediate Shipment

The Boy's Electric Toys

THE BOY'S ELECTRIC TOYS" contains enough material to MAKE AND COMPLETE OVER TWENTY FIVE DIFFERENT ELECTRICAL APPARATUS without any other tools, except a screw-driver furnished with the outfit. The box contains the following complete instruments and apparatus which are already assembled:

Student's chromic plunge battery, compass-galvanometer, solenoid, electric hammer, galvanometer, voltmeter, hook for telephone receiver, condenser, sensitive microphone, short distance wireless telephone, test storage battery, shocking coil, complete telegraph set, electric riveting machine, electric buzzer, dancing fishes, singing telephone, mysterious dancing man, electric jumping jack, magnetic geometric figures, rheostat, erratic pendulum, electric butterfly, thermo electric motor, visual telegraph, etc., etc.

This does not by any means exhaust the list, but a great many more apparatus can be built actually and effectually. With the instruction book which we furnish, one hundred experiments that can be made with this outfit are listed, nearly all of these being illustrated with superb illustrations. No other materials, goods or supplies are necessary to perform any of the one hundred experiments or to make any of the 25 apparatus. Everything can be constructed and accomplished by means of this outfit, two hands, and a screw-driver.

The outfit contains 114 separate pieces of material and 24 pieces of finished articles ready to use at once. Among the finished material the following parts are included: Chromic salts for battery, lamp socket, bottle of mercury, core wire (two different lengths), a bottle of iron filings, three spools of wire, carbons, a quantity of machine screws, flexible cord, two wood bases, glass plate, paraffine paper, binding posts, screw-driver, etc., etc. The instruction book is so clear that anyone can make the apparatus without trouble, and besides a section of the instruction book is taken up with the fundamentals of electricity to acquaint the layman with all important facts in electricity in a simple manner.

We guarantee satisfaction. The size over all of the outfit is 14 x 9 x 2 1/4. Shipping weight, 8 lbs. No. 2002 "The Boy's Electric Toys" outfit as described.....\$6.00

IMMEDIATE SHIPMENTS

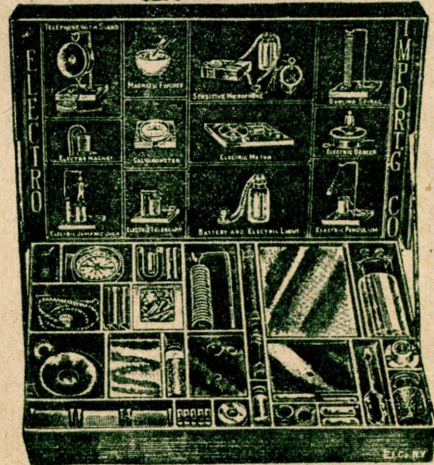
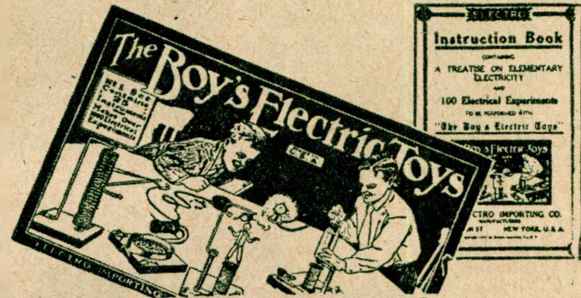

\$6⁰⁰

No. 2002

"The Livest Catalog in America"

IN this cyclopedia you will find all about radio. One of the greatest catalogs of its kind in print. You will find in it dozens of wireless instruments of the famous E. I. Co. make. Other things you will find listed to this catalog: Electrolytic Interrupters, Bull-dog Spark Coils, Chemical Outfits, Code Practice Sets, Primary Batteries, Storage Batteries, Hydrometers, Volt and Ammeters, Batterymeters, Electrolytic Rectifiers, Rheostats, Tesla Coils, Microphones,

Loud Talkers, Electro-magnets, X-ray Tubes, Telephones, Magnets, Low Tension Transformers, Books, etc., etc. IN A WORD THE MOST COMPLETE CATALOG IN PRINT.

FREE with this wonderful cyclopedia — 20 coupons for our 160 page Wireless Course in 20 lessons. 350 illustrations, 30 tables. Catalog explains how you can get this Course absolutely free.

The Electro Importing Co.,
231 Fulton Street New York
"Everything for the Experimenter"

ELECTRO IMPORTING COMPANY
231 Fulton St., New York City

I enclose herewith 10 cents in stamps or coin, to cover postage, for which please send me your latest Cyclopedia Catalog No. 22 as described.

NAME
ADDRESS
STATE S. & I. 12-20

15 Automobile Experts at Your Command



You can Earn \$50 to \$100 a week

Let these fifteen world-famous auto engineers help you into a big paying job. They can do it. The Library of Automobile Engineering written by these men will tell you everything you need know to earn \$50.00 to \$100.00 a week or more in the auto game. Start right now. More men are needed—thousands of men are needed to keep the country's eight million cars in good going condition. Over 75,000 sets of these great books have been sold on our no-money-down-easy-payment-plan. See our free offer below.

Auto Books 6 Volumes SENT FREE

No matter if you don't know a thing about automobiles now, you can learn the auto game backward and forward with these books to help you. They explain everything. They turn every make of car inside out—show you how it is made—how to repair it—how to keep it in good condition—how to go into the garage business for yourself. 6 big books bound in flexible American morocco containing 2600 pages of money-making facts and more than 2000 pictures, blueprints and diagrams. Anyone who can read can understand them.

Send No Money

You don't have to pay one cent in advance. Just mail the coupon and use the books for a whole week in your home or shop—then decide whether you want to keep them or not. If you like the books, send us only \$2.80 in seven days and \$3.00 each month until \$29.80 is paid. If you don't like them, just ship them back at our expense and you won't owe us a cent. Along with each set goes FREE a membership in this society, worth \$12.00. Mail the coupon now, before the membership is filled.

Mail Coupon Now The coupon is all you need. See the books before you pay anything. This is our guarantee that you will be satisfied. There is no risk on your part. Mail the coupon now.

Learn All About

- Automobile Motors
- Welding—Motor Construction—Repair—Carburetors and Settings—Valves—Cooling—Lubrication—Flywheels—Clutches—Transmission—Final Drive—Steering—Frames—Tires—Vulcanizing—Ignition—Starting—Lighting—Shop Kinks—Garage Design and Equipment—Electrics—Storage Batteries—Care and Repair of Motorcycles and Trucks—Gasoline Tractors and How to Repair Them.

128 Blueprints Electric Wiring Diagrams

American Technical Society
Dept. A-259
Chicago, U. S. A.



FREE EXAMINATION COUPON

AMERICAN TECHNICAL SOCIETY
Dept. A-259, Chicago, U. S. A.

Please send me the 6-volume set of Automobile Engineering for 7 days' examination, shipping charges collect. If I decide to buy, I will send \$2.80 within 7 days and the balance at \$3.00 a month until the \$29.80 has been paid. Then you send me a receipt showing that the books and the \$12.00 Consulting Membership are mine and fully paid for. If I think I can get along without the books after the 7 days' trial, I will return them at your expense.

Name

Address

Reference

\$ 3.50



Actual Size

**The First Universal
AUDION**



**Audio Frequency Amplifier
Radio Frequency Amplifier
Audion Oscillator**

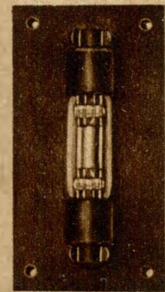

Universal Audion Receptacle \$ 1.00

RADIO AUDION COMPANY INC.

90 OAKLAND AVE., JERSEY CITY, N. J.

Manufactured under De Forest Patents No 841,387 and No 879,532

manufactured under De Forest Patents No 841,387 and No 879,532

Einstein Theory and the Fourth Dimension

(Continued from page 892)

Yet every time we have ourselves X-rayed, the particles that are shot off from the anode of the X-ray tube travel precisely at such tremendous speeds and, due to their speeds, produce such extraordinary results.

Light Is Four Dimensional.

Take a ray of light traveling 186,000 miles per second. Interpose a cube of glass that may be a yard thick between yourself and the ray of light. Altho glass is one of the hardest and densest substances known, the light ray passes right thru it as if the wall of glass were not there. Yet we have reasons to believe that light really has substance. In other words, the particles which make up light are just as solid and real as the brick shown in Fig. 2, but in moving at such a tremendous speed, these particles undergo certain physical changes, of which as yet we are ignorant because these particles truly move in the fourth dimension and, as such, are subject to entirely different laws than those which we know now.

The same is the case of radium. We know that radium shoots off highly charged alpha particles at a speed approaching that of light. These particles, which are just as real as those which make up a brick, are hurled right thru glass, metals, a human hand and most other substances as if these substances did not exist. These alpha particles, moving as they do, have a real fourth dimension otherwise they could not and would not do what we know them to do.

The Pressure of Light.

Once upon a time it was thought that light was simply a wave motion of the ether without having any substance. We are, however, slowly reverting to Newton, who, steadfastly asserted that light is corpuscular, in other words, made up of small particles, and recent investigations tend to show that Newton was not altogether incorrect. We know, for instance, that the sun exerts a certain amount of pressure on the earth, amounting to over a hundred tons. This pressure is just as real as if fine streams of water shot from the sun were pressing upon the surface of the earth. This pressure of the light is proven most effectively by a comet's tail. The tail of a comet, as we know, is always turned away from the sun no matter where the head is located in its orbit around the sun. As is well known, the tail of the comet, which is made up of thin gases, is moving in a vacuum. As the tail is sprayed with the rays of the sun a certain amount of pressure is brought to bear upon the gas particles, and they thus move away until they encounter the least resistance, which is right behind the comet's head. The comet's tail in this case behaves exactly in the same manner as a weather vane, which always places itself in the line of least resistance, pointing with the arrow to the direction whence the wind is blowing strongest. The pressure of light has been verified by many experiments on earth as well. It is shown in Fig. 7. Here we see the light ray coming from a distant star being deviated by the gravitational field of the sun. This experiment has actually been proven on a photographic plate.* If the ray of light shown in Fig. 7 was merely a wave motion of the ether, it is inconceivable how it could possibly be deflected by the sun's gravitational field.

*See "Electrical Experimenter," January issue, page 887.

"I'm A Man. I Want Man's Pay!"



That is what Albert Foster wrote us eighteen months ago, and he goes on: "I'm tired of being bossed for \$25 a week. I want a He-Man job with real pay. I want to get into the \$100 a week class. Tell me how to do it." We showed him how. Today he has a He-Man job and He-Man pay. We tell of his experience because it's typical.

WHAT ARE YOU? A man who is up and doing, getting real money, or are you simply marking time on \$25 or \$30 a week? \$100 jobs don't go begging. If you want one you've got to go after it. Are you satisfied with your present condition in life? If you are, we have nothing to offer you, but if you want one of these real jobs with big pay, then we can help you and help you in a hurry.

A REAL MAN with a real man's pay is what you want to be, and we will show you how. Without loss to you of a single working hour, we will show you a sure way to success and big pay. A large number of men in each of the positions listed are enjoying their salaries because of our help—we want to help you.

Make a check on the coupon against the job you want and we will help you get it. Write or print your name on the coupon and send it in today. You will be under no obligation.

American School of Correspondence
Dept. G 926 Chicago, U. S. A.

ARCHITECT
\$ 5,000 TO \$15,000

ACCOUNTANT
\$ 7,000 TO \$15,000

BUSINESS MANAGER
\$ 5,000 TO \$15,000

ELECTRICAL ENGINEER
\$ 4,000 TO \$10,000

CIVIL ENGINEER
\$ 5,000 TO \$15,000

AUTOMOBILE ENGINEER
\$ 4,000 TO \$10,000

AMERICAN SCHOOL OF CORRESPONDENCE
Dept. G-926 Chicago, Ill.

Explain how I can qualify for position checked:

<input type="checkbox"/> Architect \$5,000 to \$15,000	<input type="checkbox"/> Accountant and Auditor \$2,500 to \$7,000	<input type="checkbox"/> Steam Engineer \$2,000 to \$4,000
<input type="checkbox"/> Building Contractor \$5,000 to \$10,000	<input type="checkbox"/> Draftsman and Designer \$2,500 to \$4,000	<input type="checkbox"/> Foreman \$2,000 to \$4,000
<input type="checkbox"/> Automobile Engineer \$4,000 to \$10,000	<input type="checkbox"/> Electrical Engineer \$4,000 to \$10,000	<input type="checkbox"/> Photoplay Writer \$2,000 to \$10,000
<input type="checkbox"/> Automobile Repairman \$2,500 to \$4,000	<input type="checkbox"/> General Education to one year	<input type="checkbox"/> Sanitary Engineer \$2,000 to \$5,000
<input type="checkbox"/> Civil Engineer \$5,000 to \$15,000	<input type="checkbox"/> Lawyer \$5,000 to \$15,000	<input type="checkbox"/> Telephone Engineer \$2,500 to \$5,000
<input type="checkbox"/> Structural Engineer \$4,000 to \$10,000	<input type="checkbox"/> Mechanical Engineer \$4,000 to \$10,000	<input type="checkbox"/> Telegraph Engineer \$2,500 to \$5,000
<input type="checkbox"/> Business Manager \$5,000 to \$15,000	<input type="checkbox"/> Shop Superintendent \$3,000 to \$7,000	<input type="checkbox"/> High School Graduate In two years
<input type="checkbox"/> Certified Public Accountant \$7,000 to \$15,000	<input type="checkbox"/> Employment Manager \$4,000 to \$10,000	<input type="checkbox"/> Fire Insurance Expert \$3,000 to \$10,000

Name _____
Address _____



"At Last—a Real Job and Real Money!"

"And if only I'd started earlier, I could have had them five years ago. I didn't realize at first what spare time study would do for a man. Taking up that I. C. S. course marked the real beginning of my success. In three months I received my first promotion. But I kept right on studying and I've been climbing ever since."

Every mail brings letters from some of the two million students of the International Correspondence Schools telling of advancements and increased salaries won through spare time study. How much longer are you going to wait before taking the step that is bound to bring you more money? Isn't it better to start now than to wait five years and then realize what the delay has cost you?

One hour after supper each night spent with the I. C. S. in the quiet of your own home will prepare you for the position you want in the work you like best.

Yes, it will! Put it up to us to prove it. Without cost, without obligation, just mark and mail this coupon.

TEAR OUT HERE
INTERNATIONAL CORRESPONDENCE SCHOOLS
BOX 6172-B SCRANTON, PA.

Explain, without obligating me, how I can qualify for the position, or in the subject, before which I mark X.

- | | |
|---|---|
| <input type="checkbox"/> ELECTRICAL ENGINEER | <input type="checkbox"/> CHEMICAL ENGINEER |
| <input type="checkbox"/> Electrician | <input type="checkbox"/> SALESMANSHIP |
| <input type="checkbox"/> Electric Wiring | <input type="checkbox"/> ADVERTISING MAN |
| <input type="checkbox"/> Electric Lighting | <input type="checkbox"/> Window Trimmer |
| <input type="checkbox"/> Electric Car Running | <input type="checkbox"/> Show Card Writer |
| <input type="checkbox"/> Heavy Electric Traction | <input type="checkbox"/> Outdoor Sign Painter |
| <input type="checkbox"/> Electrical Draftsman | <input type="checkbox"/> RAILROAD |
| <input type="checkbox"/> Electric Marine Designer | <input type="checkbox"/> ILLUSTRATOR |
| <input type="checkbox"/> Telegraph Expert | <input type="checkbox"/> DESIGNER |
| <input type="checkbox"/> Practical Telephony | <input type="checkbox"/> BUSINESS MANAGEMENT |
| <input type="checkbox"/> MECHANICAL ENGINEER | <input type="checkbox"/> Private Secretary |
| <input type="checkbox"/> Mechanical Draftsman | <input type="checkbox"/> BOOKKEEPER |
| <input type="checkbox"/> Ship Draftsman | <input type="checkbox"/> Stenographer and Typist |
| <input type="checkbox"/> Machine Shop Practice | <input type="checkbox"/> Cert. Pub. Accountant |
| <input type="checkbox"/> Toolmaker | <input type="checkbox"/> Traffic Management |
| <input type="checkbox"/> Gas Engineer | <input type="checkbox"/> Commercial Law |
| <input type="checkbox"/> CIVIL ENGINEER | <input type="checkbox"/> GOOD ENGLISH |
| <input type="checkbox"/> Surveying and Mapping | <input type="checkbox"/> STATIONARY ENGINEER |
| <input type="checkbox"/> MEINE KOLLEGEN DRINGE | <input type="checkbox"/> CIVIL SERVICE |
| <input type="checkbox"/> ARCHITECT | <input type="checkbox"/> Railway Mail Clerk |
| <input type="checkbox"/> Architectural Draftsman | <input type="checkbox"/> Textile Overseer or Supt. |
| <input type="checkbox"/> PLUMBING AND HEATING | <input type="checkbox"/> AGRICULTURE |
| <input type="checkbox"/> Sheet Metal Worker | <input type="checkbox"/> Poultry Raising <input type="checkbox"/> Spanish |
| <input type="checkbox"/> Navigator | <input type="checkbox"/> Automobiles <input type="checkbox"/> Italian. |

Name _____
Present Occupation _____
Street and No. _____
City _____ State _____

SEND NO MONEY

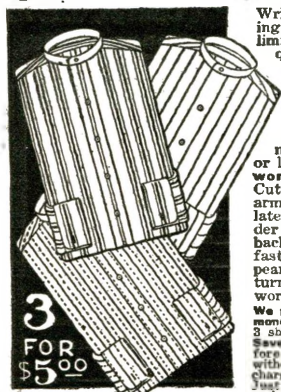

Write quick for this amazing shirt bargain. Only limited lot. Wonderful quality fine count percale. Record breaking cut price. Guarantee \$3.00 value for only \$5.00 C. O. D.

Send No Money just your name and neckband size on postal or letter for these three wonderful percale shirts. Cut extra large, roomy armholes. This season's latest black, blue or lavender stripe effects on white background. Guaranteed fast color. Best quality pearl buttons, soft French turn back cuffs, finest workmanship.

We guarantee to refund your money if you can match these 3 shirts for less than \$3.00. Save money—write today before this astounding offer is withdrawn. We pay delivery charges. You pay only \$5.00. Just send your name, address and neckband size.

BERNARD, HEWITT & COMPANY
Dept. B-3912—900 West Van Buren Street Chicago, Illinois

What are Dreams?

By **WILLIAM M. BUTTERFIELD**

(Continued from page 852)

Dreams Are Exaggerated Memories, It Is Thought

Dreams are memories; memories are recollections of past physical experiences. These experiences are obtained usually thru the sense organs. These operations are mechanical, hence dream-thoughts are mechanical reflex operations, corresponding in a reverse way, we may say, to the original spontaneous operation in the memory center. This being the case, a dream-thought can only be of some impression already in the mind.

Helen Keller, born blind, deaf and dumb, never had dreams of things that can be seen, things that can be heard, or of letters, figures, pictures, etc. Her mind was ignorant of these things and of course could not furnish dream-thoughts such as are common to people with normal sensation. Her dreams were of talking with the fingers, for example.

Innumerable cases can be given to prove the fact that dreams are mechanical operations of the brain and sense organs; that dreams are created from mental impressions obtained from previous experience; and that they are aroused by some natural stimulus, either outside or inside of the body. The mind is actively receiving impressions from the earliest infancy to the last instant of consciousness, and it is evident that new impressions are received and recorded, as additions to memory, even at the moment of dreaming.

So vast and intricate is this store of personal knowledge that the individual is unaware seemingly of the major portion of it, and it is only when some stimuli causes memory to produce a recorded portion,—very often to the wonderment of the person,—that he realizes that he possesses the bit of knowledge. A very large part of our store of sense experiences are received subconsciously, and as the mind undoubtedly retains each and every impression thru life, a considerable part of our knowledge is subconscious. Subconscious knowledge is recalled by stimuli just as any well known impression.

Day Dreams and Sleep Dreams

Such biological facts are confusing, and would be unbelievable were it not that every rational person is constantly experiencing mental reflexes that prove them. Sleep-dreams and day-dreams are common to us all; we all realize that our day-dreams at least are shaped by our personal experience; it does not, therefore, require much reflection to convince us that sleep-dreams are evolved from our personal experiences also. We are aware that many of these dreams are confused,—jumbled together,—a piece of recollection here, another there, so that no matter what effort we make we cannot, even when awake, straighten them out.

If this confused state of mental action is of common occurrence in reflection during our waking hours, we should not be surprised that sleep reflection is often jumbled, fantastic, undefinable. Sleep thoughts are composed almost entirely of impressions received from the sense of vision, and for this reason are rarely more than pictures of things, places or persons that have been seen. If the sleeper recalls words, letters, figures, drawings, and the like, it will invariably be found that these have been seen at some time also.

When words are spoken, sung or otherwise used, as in shouting or declaiming, they are in the language or languages that

(Continued on page 902)

AN EASY WAY TO MAKE MONEY

Don't be content to plod along on a small salary. Be independent. Go in the tire repairing business. One man says "I made \$50.00 the first day." Others average \$200 to \$500 monthly. Very little capital needed. Jobs plentiful. Every motorist a possible customer. No experience needed. We teach you.

SHALER Tire Repair Outfit

Improved Wrapped Tread Method Used by Tire Manufacturers
Does as good work as the big high priced vulcanizing outfits. A boy can use it. It's the only vulcanizer that has Automatic Heat Control, and can't undercure or overcure a tire. Requires no watching or regulating.

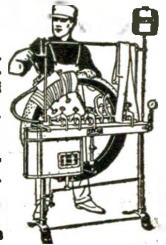

FREE Book
"How to Open a Tire Repair Shop." It tells how to make big money. Don't delay. Write quick.

C. A. SHALER CO.
2211 Fourth St. Waupea, Wisconsin

TIRES ORDER THEM BY MAIL SAVE 65%
GTD 5000 MILES

A High Standard reconstructed tire at prices equal to 65% Saving Ask for them by name.



Superior Tires

Are recommended for their durability, long service, and resiliency. Each tire has supplemental rubber as precaution against blowouts, pinches, etc., and three extra layers of ground fabric.

Guaranteed 5,000 Miles

Size	Price	Size	Price
30x3 1/2	6.50 2.10	32x3 3/4	10.75 2.50
32x3 1/2	7.50 2.20	34x3 1/2	11.00 2.00
32x4	8.50 2.40	36x3 1/2	11.00 3.00
34x4	8.75 2.40	36x4	12.75 3.00
36x4	9.00 2.50	32x5	12.75 3.20

Retainer Free With Every Tire
State whether you want straight side or clocher, plain or non-skid. Send \$2.00 deposit for each tire; \$1.00 deposit on tubes; balance C. O. D. subject to examination, or 5% discount if full amount is sent with order.

SUPERIOR TIRE & RUBBER CO.
633 First Avenue Department 612 New York City

Seneca Built for the Owner \$1185

Simple, Sturdy construction. LOW cost of up-keep and operation. Cantilever springs in rear. Comfortable E-Z riding.
4 cyl. - 27 H. P. 105 in. wheel base
Immediate deliveries. Fifth successful year. Increased output. Liberal new market advertising in dealers' territory. Wonderful opportunities. Write or Wire NOW.
THE SENECA MOTOR CAR CO., 52 Seneca Factory, FOSTORIA, OHIO



Learn Autos and Tractors

Wonderful opportunities constantly offered trained men; we train you thoroughly to start your own business or make good money as motor expert, driver, shop foreman, etc.
5000 Graduates making good. Catalog Free.
Cleveland Automobile School, 1807 E. 24th St., Cleveland, O

Tire Agent
We want one exclusive representative in each locality to use and sell the new Mellingier Extra-Ply, hand made tires. **Guarantee Bond for \$3000 Miles.** (No seconds). Shipped prepaid on approval. Sample sections furnished. Don't buy until you get our Special Direct Prices. Write **MELLINGER TIRE & RUBBER CO.** 901 Oak St. Kansas City, Mo.

You Can Save \$50.00

By recovering your old auto for you frame yourself. We make these recovery to fit all makes and models of cars. Any person that can drive a car can put it on. Roof and quarters new. We furnish instructions, curtain, fasteners, wails and tacks. All complete. Give us the name, year and model number of your car and we will send you our catalogue with samples and quote you exact price.
LIBERTY TOP & TIRE CO., Dept. E4, Cincinnati, O.

CONVERT YOUR BICYCLE INTO A MOTOR CYCLE

by using a **STEFFEY ATTACHMENT**
Simple-Reliable-Economical
Fits any ordinary wheel, diamond, double-bar or truss frame. Easy to attach. Send stamp for circulars.
STEFFEY MFG. CO.
Dept. E, 5025 Brown Street, Philadelphia, Pa.





Buy the Best Watch Right

MY GUARANTEE

If a Santa Fe Special Watch fails to perform its duty properly through original defective material or workmanship it will be repaired by us without a cent of expense to you or replaced by a watch of the same grade. This wonderful watch will without a doubt last a lifetime and give satisfactory service and is within the reach of every working man.

It's Easy to Own a Santa Fe Special

A Railroad Man is always a good judge of watches. And all along the line, from the engineer and the dispatcher to the telegrapher and the track-walker, whenever you find a railroad man carrying a SANTA FE SPECIAL you will find him satisfied with it. This watch has enabled me to boast that I have customers who are boosters in every section of the United States. Why shouldn't I be so proud of it that I will advise you to buy no other? If you need a watch for yourself, or are thinking of buying one for a friend or relative, let me tell you about this wonderful timepiece and explain my easy payment plan before you buy. I will give you the greatest guarantee of service and satisfaction that can be made.

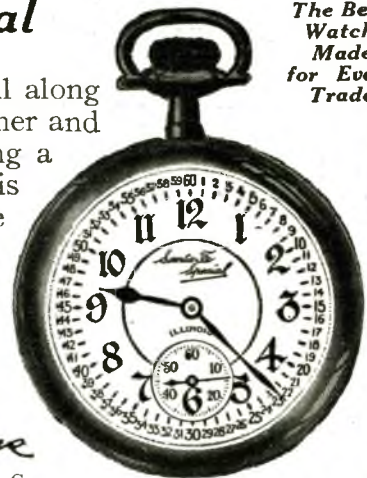

The Best Watch Made for Every Trade

Signed, *Alvord Thomas*
Pres. Santa Fe Watch Co.

Christmas orders and orders for special occasions should not be delayed. **Don't wait! Send in your order today.**

The **ILLINOIS Famous** \$ **3.50**
Santa Fe Special
21 JEWEL RAILROAD WATCH **A MONTH**

The Standard Railroad Watch that is GUARANTEED FOR A LIFETIME OF SATISFACTORY SERVICE. These watches are now in service on practically every railroad in the United States and in every branch of the Army and Naval Service. Thousands of them are distributed around the world. Your name or monogram and any emblem you may desire will be engraved in the case to suit your own ideas. Write today for my Free Watch Book to make your selection.

Save One-Third to One-Half of your Money—Most Liberal Offer Ever Made.

Our "Direct-to-you" low wholesale terms and Extra Special Distribution Plan is fully explained in the New Santa Fe Special booklet just off the press. The "Santa Fe Special" plan means a big saving of money to you and you get the best watch value on the market today—watch sent for you to see without one penny down.

New Case Designs

I want you to see the newest designs in cases used on these "Santa Fe Special" Watches, so you will fully realize their beauty and up-to-dateness, as well as the value of the Bargain I am offering you. I want you to see the 3-color inlay work—think how distinctive and personal Your Watch would be with your own name, monogram or some appropriate emblem engraved in the case, just to suit your own ideas. You will also want to see the new French Art designs in engraved cases—all shown in My New Free Watch Book, printed in beautiful colors. Write today, it will be sent FREE.



Santa Fe Watch Company

Dept. C-80
Thomas Building,
Topeka, Kans.

Hon. Champ Clark,
House of Representatives,
Washington, D. C.

"I have carried a 'Santa Fe Special' for three or four years and find it to be an admirable timepiece."

CHAMP CLARK.

A letter, post card
or this coupon will bring
my Beautiful Watch Book FREE

SANTA FE WATCH COMPANY
Dept. C-80, Thomas Bldg., Topeka, Kans.
Please send me your New Watch Book with the understanding that this request does not obligate me in any way.
Name
Address
State

Listen



Be A CERTIFICATED ELECTRICIAN

THIS IS YOUR CHANCE OF A LIFE TIME

I am Chief Engineer of the great Chicago Engineering Works. I am in close official touch with the electrical world. I know how badly we need trained electricians who can take charge of important work as experts. Right now there is such a need for executive electricians that I am making a special effort to help meet the demand. I am publishing this special announcement to secure a certain number of ambitious men whom I will personally train by mail for the wonderful opportunities that are open.

I WILL MAKE YOU a Trained Electrician

I don't care how young or old you are, just as long as you can read and write and have a spark of ambition. I don't care where you live or what you do. I don't care if you don't know a blessed thing about electricity. Just give me a little of your spare time for a short period and I'll show you the quick way to success in electricity. You can qualify to earn \$65 to \$175 a week with opportunities for greater earnings.

I Train You By Mail!

Your spare time will do. No interference with your regular duties. I understand just what you must know and I have devised a wonderful way of instructing by mail. I positively guarantee your satisfaction.

FREE Wonderful Electrical Outfit

Absolutely free. Not a penny cost to you now or later. To those who enroll now I will give a wonderful set of Electrical Equipment with my compliments. Write me at once. I have only a limited number of sets to be given free. Drop me a post card or letter.

Write! You will have to act quick to get in on this opportunity. Write me today for full particulars. Drop me a post card. *Write Now.*

CHIEF ENGINEER COOKE

Chicago Engineering Works
Dept. 520y

1918 Sunnyside Ave. Chicago, Illinois

Home Electricics

(Continued from page 862)

A New Double Base Lamp

After considerable experimentation with extensible equipment of various kinds, the double base lamp shown has been developed by E. O. Schweitzer. This lamp may be made up in any style and capacity, but the one shown in the figure is a 60-watt Mazda B lamp, that is, the filament and filament mounting details are the same as for the standard S-21 bulb, 60-watt, 115-volt Mazda B lamp, but the lead wires and the details connected with them are standard 500-watt, type C, 115-volt specification. These heavy lead wires continue thru from base to base and the lamp filament is tapped off from them. The cane glass stops about one quarter of an inch from the secondary press, and furthermore the lead wires are formed into what might be termed an expansion loop, so that altogether there is no possibility of strain being set up due to unequal contraction and expansion of the bulb, cane, and lead wires.

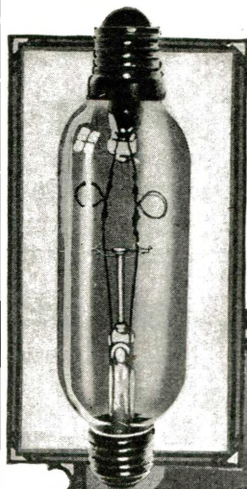

How Often Have You Desired to Connect Some Auxiliary Electrical Appliance to the Nearest Electric Outlet Overhead? By the Use of This Double Base Lamp Which Has Feed Wires Running Directly Through It, Besides the Usual Filament, It Becomes Possible to Connect Any Apparatus Desired to the Bottom of the Lamp by a Single Plug Attachment.

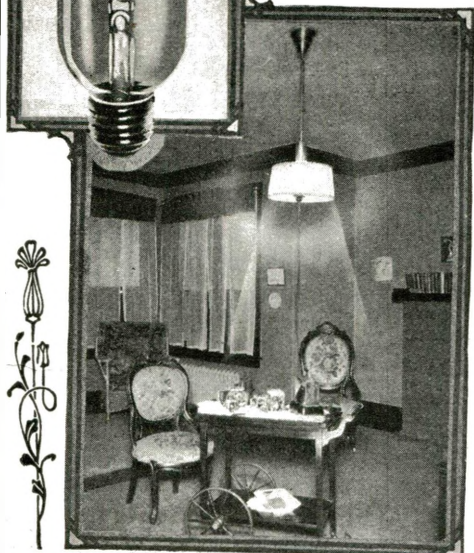

Incidentally this is a tiptless lamp, exhaustion of the bulb being carried out by means of a sealed-off tube concealed within one of the bases.

The lead wires are given a quarter twist in passing between the two ends of the lamp so as to provide clearance for the filament anchors. The lamp is furnished with the simple receptacle connector shown in Fig. 2, which is merely a duplication of the threaded portion of a medium screw base socket shell surrounded by either a fiber ring or with the addition of a light brass shell beaded at each end for use with any standard shade holder. This connector makes the lamp safe to manipulate and allows of any standard attachment plug being screwed in from the free end; or it permits any number of these double base lamps to be strung in parallel for such purposes as window or showcase lighting, etc., etc.

FREE Puncture Proof Tube 6,000 Miles Guaranteed



For a limited time only we are offering absolutely free a puncture proof tube guaranteed 6,000 miles, with every purchase of one of our famous Reliable Double Tread Tires which are guaranteed 5,000 miles and often give 8,000 to 10,000.

4 Reasons for Buying this Bargain Offer

- 1—6,000 miles without a puncture!
- 2—Save repair bills!
- 3—Save entire cost of tube!
- 4—Save money on tires!

Price	Tires	Size	Tubes
30 x 3	\$6.95	35 x 4	\$12.00
30 x 3 1/2	7.95	36 x 4	12.50
32 x 3 1/2	8.75	34 x 4 1/2	12.75
34 x 3 1/2	9.00	35 x 4 1/2	12.95
31 x 4	9.95	36 x 4 1/2	13.25
32 x 4	10.25	37 x 4 1/2	13.75
33 x 4	10.90	35 x 5	13.95
34 x 4	11.25	37 x 5	14.50

Free Rollin' With Each Tire

In ordering be sure to state size wanted, also whether a clincher, plain or non-skid. Send \$2.00 deposit on each tire, balance C. O. D. subject to examination; 5 per cent discount if you send full amount with order. Rush your order today.

RELIABLE TIRE & RUBBER CO.
3473 Michigan Ave. Chicago, Ill.

YOU Can Do YOUR Own SOLDERING and All Metal Repairing With



USED BY U. S. AND ALLIED

A PASTE THAT TURNS INTO METAL WHEN HEATED

A match will do it. Requires no acid or soldering iron. Joins or repairs wires, metals or metalware. Sold by hardware and electrical stores or sent by us postpaid.

SOLDERALL CO., Dept. E.
129 Sussex Ave., Newark, N. J.

COMBINATION SET
Tube and Torch Complete \$1.50

Dealers Send for Quantity Prices.
Look for Trade Mark "SOLDERALL"
Beware of imitations with similar names

RICHARDSON'S POLYPHASE SLIDE RULE



has the regular A, B, C, and D Scales; also a CI or Polyphase Scale, Logarithm, Sine and Tangent Scales. All graduations are printed on white coated steel from engine divided plates. These Scales are accurate and will retain their accuracy indefinitely. They are not affected by acids, alkalis, water or grease. Length of rule 10". A 100 page Instruction Book which teaches all there is to know about slide rules, is sent with each order.

Price of the Richardson's Polyphase Slide Rule, in case with 100 page Instruction Book \$2.00.

An ideal Slide Rule. It is low priced and an equal to any other rule in appearance, accuracy and durability. Be convinced. Your money will be promptly refunded if you are not satisfied.

Send for our 40 page catalogue of supplies. It describes rules ranging from 50c to \$10, each. Instructions in Logarithms and Trigonometry free with every catalogue.

GILSON SLIDE RULE CO. NILES, MICH.

Send No Money

Profit Smashing Bargain—Just send your name, address, size and color for 6 pairs of these handsome, durable, genuine Duo-Web silk socks. Pay only \$5.19 for 6 pairs on arrival. **GUARANTEED \$5.00 VALUE.** Wonderful quality, extra heavy silk. Elastic ribbed top. Double toe and sole, high spliced heel. Choice of brown or black. Fast colors. Writetoday for this outstanding offer. Limited quantity. On 6 pairs to a customer. Shipped deliver charges paid. Pay only \$3.19 on arrival. Money back if you can match them for \$6.00. Dept. L-3912

EXTRA QUALITY SILK

SMASHING OFFER 6 PAIRS SILK SOCKS. Guaranteed \$5.00 value.

Don't send a penny. Pay only \$3.19 on arrival.

BERNARD-HEWITT & CO., 900 W. Van Buren, CHICAGO



158 Genuine Foreign Stamps—Mexico War Issues, Venezuela, Salvador and India 10c. Service, Guatemala, China, etc. Only finest 10c approval sheets, 50 to 50%. Agents Wanted, Big 72 p. Lists Free. We Buy Stamps. Estab. 25 yrs. Husman Stamp Co., Dept. 118, St. Louis, Mo.

Get Pulsating HEALTH

From the Vibrant Forces of
High Frequency
Electricity

**Sold
On Trial**

Not limited to a few days—but giving ample opportunity to determine benefits in your case.

V RenuLife Y VIOLET RAY

You Can Expect Results Like These Users:

"The RenuLife Violet Ray High Frequency Generator is superior in efficiency because of its perfect character and control of current, compactness and perfect insulation. The smallness and lightness of Electrode holder is also a great advantage." "The doctor told me that the trouble was hardening of the arteries. I would not be without it for all the money in the world." "I cannot recommend it too highly." "I have been using mine now for a week for Sciatica and I am highly pleased with results." "I think it is one of the best little machines that was ever invented." "I have used it with excellent results for the restoration of hair and stiff and sore rheumatic finger joints." "Am well pleased with the Generator, and the kind treatment received from your Company." "My Generator has stopped my neuritis." "Every house should have a RenuLife Violet Ray High Frequency Generator for the treatment of Neuralgia; Neuritis; Sore Throat; Kernels in Neck; Cramps; Headache; Stiff Neck; Muscular Soreness; Rheumatism; Paralysis; in short, pain of all kinds."—M. D.

"I have been much relieved by the use of your Violet Ray Generator."
"It is fine for insomnia."
"I find it such a help in nervousness."
"I would not part with it for five times the price. It is sure a little wonder."
"I am more than pleased with the Generator; the whole family are using it."

In Your Own Home

Are you in bondage to ill-health? Suffering or handicapped by the lack of success-attaining, energetic, vigorous, natural *Health*? Then learn of Nature's inexhaustible store of *Health-bearing* forces—now ready to help you overcome suffering—build up strength—recuperate normal, healthy conditions. You can get this beneficial cooperation and help right in your own home. Recharge your body with the vibrant forces of electricity—through the *RenuLife Violet Ray*—a source of pulsating dynamic health—the foundation of happiness and success.

Electricity is sprayed into your body—thousands of volts—quicken circulation, purifying the blood, imparting new vitality and strength. Local pains, aches and disorders disappear, while the entire physical being takes on new tone. Send for book explaining all this interesting subject.

Many Thousands Benefited

The wonderful RENU LIFE VIOLET RAY GENERATOR transforms the electric current from your light socket into this powerfully effective health-giving administration as safe and pleasant as a ray of sunshine—No Shocks or Jolts—just a feeling of well being—permanently beneficial. Simple and safe for anyone to use.

Most remarkable results have been obtained in many chronic cases of nerve disorders, faulty circulation, anemia, paralysis, rheumatism, neuritis, catarrh, lumbago, soreness, lameness, etc. See list on coupon. Get the record of hundreds of cases.

RENU LIFE ELECTRIC CO. 1212 MARQUETTE BLDG., DETROIT, MICH.

New York City
27 Warren St.

Canada Windsor, Ont.
Netting Bldg.

SALES DISTRIBUTORS WRITE
For Proposition on Exclusive Territory

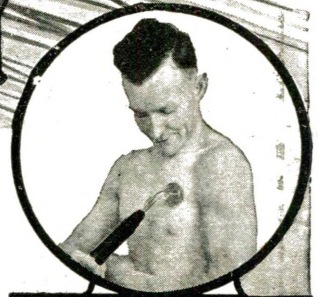

Energizer. Saturate your body with revitalizing Violet Rays.



Stops Aches. The quick action in abating pains and aches is truly marvelous.



Rheumatism, Lumbago, neuritis greatly benefited.



For Skin and Scalp. Have beauty parlor at home.

Get FREE Violet Ray Book

The application of electricity in this harmless and pleasant form—the Violet Ray—is the modern way to re-establish natural and healthy conditions. Write for Book giving full explanation.

COUPON FOR BOOK and Special Information

RENU LIFE ELECTRIC CO.,
1212 Marquette Bldg., Detroit
Please send without obligation your book "Health," explaining Violet Ray treatments with RenuLife Generator; also give full particulars as to its application for ailments checked below.

TREATS SUCCESSFULLY

- | | | |
|-----------------------------|-----------------------|-----------------------------------|
| • Abscesses | • Facial Neuralgia | • Obesity |
| • Anemia | • Falling Hair | • Pain in Abdomen |
| • Asthma | • Female Complaints | • Pain in Chest |
| • Arteriosclerosis | • Glands | • Paralysis |
| • Baldness | • Gout | • Piles |
| • Blackheads | • Hemorrhoids | • Pimples |
| • Brain Fog | • Hay Fever | • Pyrexia |
| • Bronchitis | • Infantile Paralysis | • Rheumatism |
| • Bunions | • Insomnia | • Scars |
| • Bruises | • Lameness | • Sciatica |
| • Catarrh | • Locomotor Ataxia | • Skin Diseases |
| • Colds | • Lumbago | • Sore Throat and Throat Diseases |
| • Chills | • Nervous Affections | • Sprains |
| • Chlborrhea | • Neuritis | • Toothache |
| • Dandruff | • Neuritis | • Weak Eyes |
| • Deafness and Ear Diseases | | • Wrinkles |
| • Eczema | | • Warts and Moles |
| • Enlarged Prostate | | |

Name

Address

Several
SIZES
Most
Efficient
Lowest
Priced



Learn in Spare Time to be a CIVIL ENGINEER

Earn \$1500 to \$5000 Yearly
Here's your big chance to become a full-fledged Civil Engineer! With this set of books you can fit yourself to make big money in the greatest outdoor profession on earth! Offer fully explained in coupon. Good only within boundaries of the U. S. and Canada.



Great Books Shipped FREE
75c a Week if you keep them after 7 days' FREE TRIAL.
Nine big leather-bound volumes: 3900 pages 7x10 inches; 3000 plates, maps, diagrams, etc. Written by world's greatest civil engineers. Books tell you ALL ABOUT surveying; highway construction; railway engineering; earth work; specifications; estimating contracts; bridge engineering; masonry; reinforced concrete; water supply; sewers and drains; water power equipment; irrigation; engineering, etc., etc. Written in simple language—every point made plain.
Consulting Service Free
A \$12 Consulting Membership solves your difficult problems for a whole year. FREE with the set of books. **SEND NO MONEY—JUST THE COUPON!**

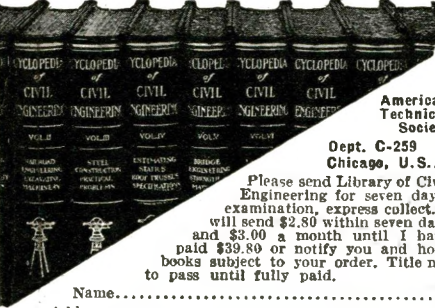

American Technical Society

Dept. C-259
Chicago, U. S. A.

Please send Library of Civil Engineering for seven days' examination, express collect. I will send \$2.80 within seven days and \$3.00 a month until I have paid \$39.80 or notify you and hold books subject to your order. Title not to pass until fully paid.

Name.....
Address.....
Reference.....

Different from all others—the NEW BENJAMIN



AIR RIFLE

shoots harder and farther than any other. Made on a new principle. Is really a strong air-pump, compressing air in the air-chamber to any degree of power desired. Each stroke gives increased power, one to six strokes being sufficient.

Works like air-drills and air-hammers—with this difference:

You control shooting force. This block of hard-wood shows penetrating power of each charge. No other air rifle can duplicate this feat.

The Benjamin is safe, because you control the power. Never loses shooting force—has no springs to get out of order.

Write for interesting folder about this wonderful gun. At all dealers, \$5.00 Ask your dealer for demonstration.

Benjamin Air-Rifle & Mfg. Co.
619 N. Broadway
St. Louis, Mo.

Pacific Coast Representatives:
McDONALD & LINFORTH, Call Bldg.,
San Francisco.

LEARN ENGINEERING

Expert electrical engineers are being paid fabulous salaries. Thousands needed today. We give you personal and thorough training—practical, technical courses three months to two years, under expert engineers in electricity, steam, gas, auto, armature winding, drafting, etc. Extensive laboratory and shop equipment. Not a trade school. Enroll anytime. Do not judge us by size of ad but write for free illustrated catalogue.

FINLAY ENGINEERING COLLEGE
Greatest of its kind

1001 Indiana Avenue Kansas City, Mo.

Handwriting Tells You Secrets

Be successful. Find out what holds you back. Send us an ink specimen of your handwriting and \$1.00. Our expert Graphologists will tell you your faults, virtues, talents, etc. Your \$1.00 back if you are not satisfied.

ROBERT R. ROSS, 110 West 40th St., N. Y.

What are Dreams?

(Continued from page 898)

the user is familiar with, or has heard. It is during sleep that the most remarkable exhibitions of recalled subconscious knowledge are manifested. It is often expressed by the sleeper, speaking words in a foreign tongue, words that have been heard but the meaning of which is unknown. Other subconscious impressions are recalled to create a mental picture that appears new or original.

Prophetic, inventive or creative dreams are developed from our subconscious knowledge. Nightmares, night-terrors,—common to the child and the feeble-minded,—as well as most dreams of a mysterious nature are created from subconscious mental complexes. Dr. Sigmund Freud attempts to trace all dreams to infantile and childhood complexes, because he sees hidden in every dream a wish—fulfillment,—that is, dreams express yearnings, cravings, hopes, and desires that have not otherwise been fulfilled. Tho it is true, that all our acts, or thoughts governing them, are really directed by our desires, we can hardly say that a nightmare or night-terror is a wish-fulfillment or a reflection of a wish.

The stimuli that recalls knowledge to the mind may be an incitement or spur as intricate and elusive as the thought that produced it. It may be received consciously or subconsciously, and from without or within the body; thus we have dreams caused from the want of food, or from food, drink or drugs, that abnormally excite sensation. Cold, heat, light, sound, odor, all form external stimuli. Whatever form the inciter or inciters may have, they are all received thru the sense organs,—or to a degree thru the bone, tissue and other parts as some investigations claim—and indicate physical or external conditions which the mind is to determine by means of memory as favorable or unfavorable to the welfare or contentment of the person.

Dreams are therefore, in common with all thought, important aids to our physical machinery, and are formed seemingly to rest the body by a pleasing assurance of safety or to arouse the mind to action in an effort to protect the body from some threatened danger. Dreams or thoughts that dwell continually upon one subject are incited usually as danger signals and are commonly the product of a diseased mind or an infected physical organ. It is advisable when dreams or thoughts persist in this way to consult a physician, for dreams are not as Shakespeare says "children of an idle brain," but are, in this case, as well as all other cases, children of an active brain, seeking to arouse or to soothe the mind in its subdued control of the body in sleep.

Healthy Versus Unhealthy Dreams

When a person's body and mind are in a healthy, normal condition, he often has day dreams which are of a pleasant character, recalling and visualizing incidents of bygone days. Such visions are restful to the man who comes home tired, after long business hours and constant poring over books of law or other work, necessitating great mental strain. More often, however, we have dreams, which, as have been explained before, may be excited by either internal or external stimuli. Thus, in our center illustration, we see a dream caused by the cold air blowing upon a child's legs. Immediately this stimulus is transmitted to the brain where a picture

(Continued on page 904)

Order Your Scientific and Technical Books Now.

They are difficult to obtain and prices are constantly increasing. We will quote present price on any book of this nature and the price will hold unless the publisher should increase his price in the interim.

Write for our 96-page catalogue—the most complete scientific and practical catalogue now issued. In addition, our 1920-1921 list will be sent you as soon as ready, and the prices in this list will hold good in possibly 80 per cent of cases; but you will be notified of any change before filling order.

There will be no obligation in requesting catalogue for we want you to know our Book Department. Write today. You'll find it valuable for suggesting books you need.

SCIENTIFIC AMERICAN PUBLISHING COMPANY

Room 655, Woolworth Bldg., New York City

Electrical men with training are in demand. For more than a quarter of a century, this school has been training men of ambition and limited time, for the electrical industries. Condensed course in Electrical

Engineering

enables graduates to secure good positions and promotions. Theoretical and Practical Electricity. Mathematics, Steam and Gas Engines and Mechanical Drawing. Students construct dynamo, install wiring and test electrical machinery. Course with diploma complete

In One Year

Over 3000 men trained. Thoroughly equipped fireproof dormitories, dining hall, laboratories, shops. Free catalog. 28th year opens Sept. 29, 1920

BLISS ELECTRICAL SCHOOL
260 TAKOMA AVENUE, WASHINGTON, D. C.

WONDERFUL WIRELESS TELEGRAPH

Two Instruments & 2 Codes, with which you can Telegraph from house to house without wires. 10 675.
UNIVERSAL CO., DEPT. K Stamford, Conn.

GET ON THE STAGE

I Tell You How! Stage Work and Cabaret Entertaining successfully taught by mail. Your BIG opportunity. Travel, see the world as vaudeville actor or actress. My great Professional Course—only one of its kind—COVERS ALL BRANCHES. Develops Personality, Confidence, Skill and tells you just how to get on the Stage. Send 6c postage for illustrated booklet, "All About Vaudeville." State age and occupation. Write for this free Stage Book today!
FREDERIC LA BELLE Box 557 W LOS ANGELES, CALIF.

Clearstone Phonographs

\$4.00 to \$200.00 Retail
Our Sundry Dept. offers Needles 39c per thousand. Motors \$1.35 to \$14.75 each. Tone-Arms and Reproducers \$1.30 to \$5.75 per set. Main Springs 20c to 90c each. Records, Needles, Sapphire Points and Parts at reasonable prices.
Write for our 94-page catalogue, the only one of its kind in America, illustrating 33 different styles of Talking Machines and over 500 different Phonographic Parts.
LUCKY 13 PHONOGRAPH COMPANY
Export Dept. 46B East 12th Street, N. Y.

NO STAMMER MORE

Kill the fear of stammering. Re-education the key. The widely famed Hatfield Method fully outlined in an accurate, dependable, worthwhile book—HOW TO STOP STAMMERING. It has inspired thousands. Order a copy from THE HATFIELD INSTITUTE, 109 N. Dearborn, Chicago, Illinois

Book on Law Free

Write today for our new 171-page book on "The Power of Law Training." It carries a vital and inspiring message to every ambitious man. Find out about the opportunities that await the law trained man. Find out how you can learn from masters of the law right in your own home. No obligations. The book is absolutely FREE.
Write Today—now while we are making a special reduced price offer.
American Correspondence School of Law
7449-3601 Michigan Ave., Chicago, Illinois

ARE YOU BASHFUL, TIMID

Self Conscious, Embarrassed in Company. Let us tell you how you can overcome these troubles and acquire Poise, confidence, assurance and a magnetic personality. Address The Veritas Science Institute, 1400 Broadway, New York, Desk 15.

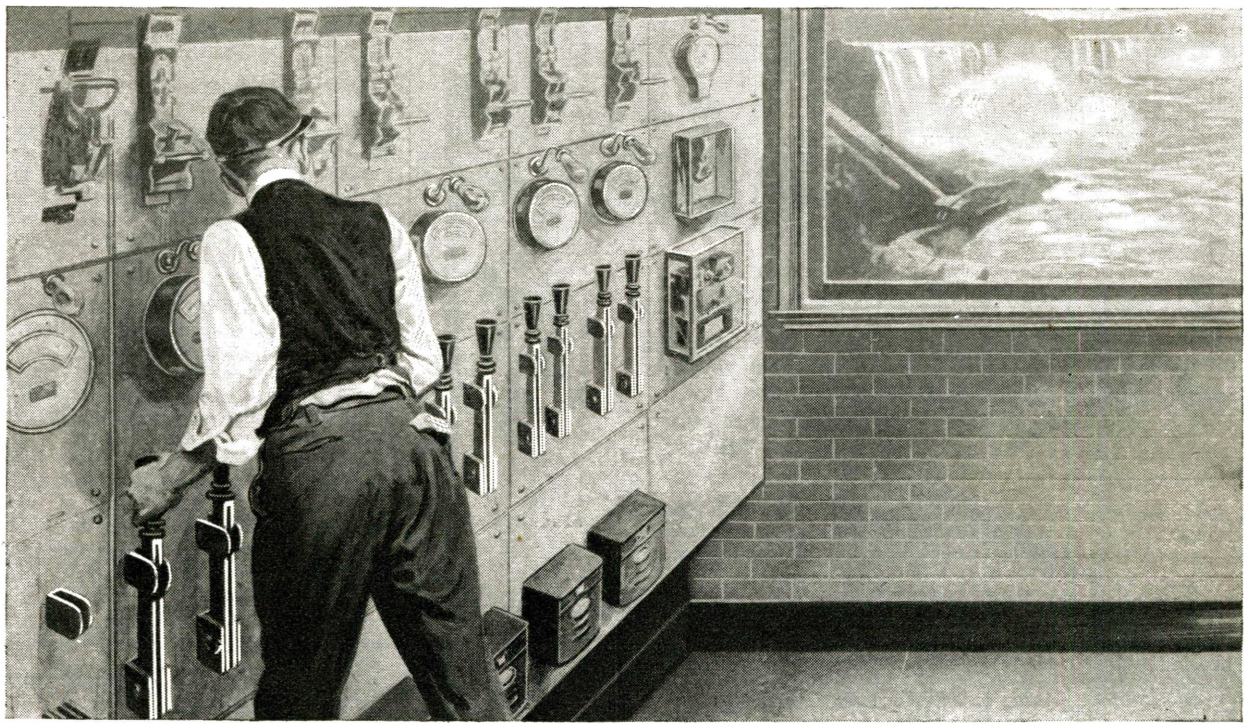

Electricity

Learn At Home

THERE is a wonderful opportunity right now for young men who like electricity. If you are ambitious and will train yourself in spare time you can step into a good position and get experience that will give you a real start toward success in life. Good salaries are offered with rapid promotion.

For 29 years the International Correspondence Schools have been training young men for success in electricity and over 200 other subjects. They will help you prepare right at home for a position in the line of electrical work you like best—or in any other work that appeals to you. Thousands of men, through I. C. S. training, have stepped into fine jobs, but never were opportunities so great as now.

Let the I. C. S. help you. Choose the work you like best in the coupon below, then mark and mail it today. This doesn't obligate you in the least, and it will bring you information that may start you on a successful career. This is your chance. Don't let it slip by. Mark and mail this coupon now.

"I am familiar with the text-books and method of instruction used by the International Correspondence Schools in their Courses in Electrical Engineering, and I also know of a number of young men who have taken these courses with great benefit. I believe that any young man will find it a practical and economical way to acquire a knowledge of the profession."
—DR. CHARLES P. STEINMETZ.



STEINMETZ

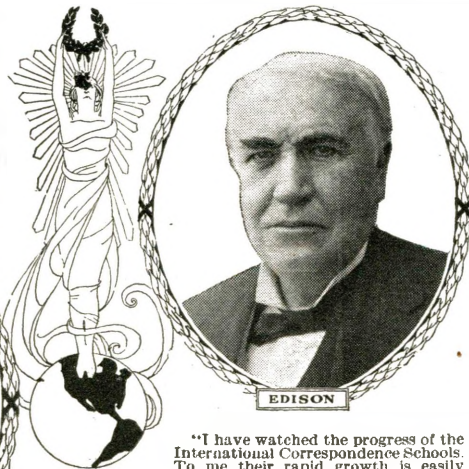

EDISON

"I have watched the progress of the International Correspondence Schools. To me their rapid growth is easily understood, because I realize the practical value that is back of them and know something too of the success attained by many ambitious men who have taken their courses.
"May your institution continue to so grow and flourish that the world will come to appreciate the actual worth of the I. C. S. trained men."
THOMAS A. EDISON.

TEAR OUT HERE

INTERNATIONAL CORRESPONDENCE SCHOOLS

BOX 6170-B, SCRANTON, PA.

Explain, without obligating me, how I can qualify for the position, or in the subject, before which I mark X.

- | | |
|--|--|
| <input type="checkbox"/> ELECTRICAL ENGINEER | <input type="checkbox"/> CHEMICAL ENGINEER |
| <input type="checkbox"/> Electrician | <input type="checkbox"/> SALESMANSHIP |
| <input type="checkbox"/> Electric Wiring | <input type="checkbox"/> ADVERTISING MAN |
| <input type="checkbox"/> Electric Lighting | <input type="checkbox"/> Show Card Writer |
| <input type="checkbox"/> Electric Car Running | <input type="checkbox"/> Outdoor Sign Painter |
| <input type="checkbox"/> Heavy Electric Traction | <input type="checkbox"/> RAILROADER |
| <input type="checkbox"/> Electrical Draftsman | <input type="checkbox"/> ILLUSTRATOR |
| <input type="checkbox"/> Electric Machine Designer | <input type="checkbox"/> DESIGNER |
| <input type="checkbox"/> Telegraph Expert | <input type="checkbox"/> BUSINESS MANAGEMENT |
| <input type="checkbox"/> Practical Telephony | <input type="checkbox"/> Private Secretary |
| <input type="checkbox"/> MECHANICAL ENGINEER | <input type="checkbox"/> BOOKKEEPER |
| <input type="checkbox"/> Mechanical Draftsman | <input type="checkbox"/> Stenographer and Typist |
| <input type="checkbox"/> Toolmaker | <input type="checkbox"/> Cert. Public Accountant |
| <input type="checkbox"/> Machine Shop Practice | <input type="checkbox"/> Traffic Management |
| <input type="checkbox"/> Gas Engineer | <input type="checkbox"/> Commercial Law |
| <input type="checkbox"/> CIVIL ENGINEER | <input type="checkbox"/> GOOD ENGLISH |
| <input type="checkbox"/> Surveying and Mapping | <input type="checkbox"/> Common School Subjects |
| <input type="checkbox"/> MINE FOREMAN OR ENGINEER | <input type="checkbox"/> CIVIL SERVICE |
| <input type="checkbox"/> ARCHITECT | <input type="checkbox"/> Railway Mail Clerk |
| <input type="checkbox"/> Architectural Draftsman | <input type="checkbox"/> STATIONARY ENGINEER |
| <input type="checkbox"/> PLUMBING AND HEATING | <input type="checkbox"/> Textile Overseer or Supt. |
| <input type="checkbox"/> Sheet Metal Worker | <input type="checkbox"/> AGRICULTURE |
| <input type="checkbox"/> Ship Draftsman | <input type="checkbox"/> Poultry Raising |
| <input type="checkbox"/> Navigator | <input type="checkbox"/> AUTOMOBILES |

Name _____

Occupation & Employer _____

Street and No. _____

City _____ State _____

"I JUMPED FOR JOY"

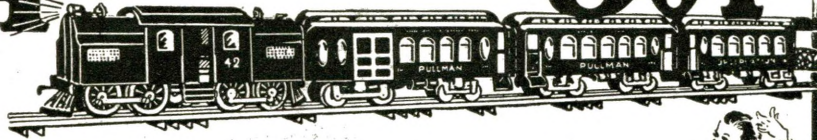

That's the Happy Message of a Lucky Boy

after he had been given a Lionel Train by his parents. It will be the *big joy time* of your youth when you open that nice box with its beautiful label and find inside—wrapped in soft tissue paper to keep it from being marred—a splendid Lionel Electric Train with a "Multivolt" Transformer.

Oh! Boy—Imagine it! A complete railroad system with electric lighted trains, powerful quick-acting electric motors, stations, tunnels, bridges, semaphores—good for years of daily fun. Send quick for



Hooray!

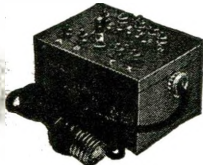

Your Power Plant
Lionel Multivolt Transformer

Runs your trains on house current at less cost than batteries. Get one with your train.

BIG FREE CATALOG in COLORS

Then Get Your Train From Your Dealer Catalog shows trains, stations, tunnels, bridges, 'n' ev'rything in actual colors. Free—send for it, pick out your train, then take Dad down to your dealers and show him the dandy railroad system you want for Christmas. If your dealer hasn't Lionel Trains write us his name and address and we'll see that you're supplied.

THE LIONEL CORPORATION
50-X, East 21st St. New York City

LIONEL ELECTRIC TOY TRAINS

& Multivolt Transformers

What are Dreams?

(Continued from page 902)

of the child walking thru a blizzard forms and she dreams she is lost in an ice cave, carrying a tremendous icicle in her arms and walking barefoot in snow six inches deep. This is one of Nature's ways of announcing to the individual the danger she is in.

Again, we can have a dream induced by internal conditions, such as a heavy indigestible meal just prior to bedtime, which generally will produce nightmares. Such nightmares are always of objects previously seen but often somewhat distorted.

The cat and dog in our right-hand illustration assume fantastic shapes and cause the individual to arise in terror. A nightly repetition of such dreams indicate a diseased body or mind, and it is advisable for those having them to consult a reputable physician, for such dreams are but one of Nature's methods of warning the person of some physical ailment.

Xmas Electric Amusements

(Continued from page 873)

There are several ways in which to procure the "animals" for this miniature merry-go-round, the five-and-ten cent stores supplying several different kinds made out of celluloid, cardboard, etc. Or you can make them yourself and paint them with water colors; or again, they may be cut out of children's picture books of animals and glued on to cardboard or thin wood and cut out with a fret saw or jack-knife. The animals may also be made of tin.

Building a Toy Scenic Railway

Fig. 4 shows a scheme for building a miniature electric scenic railway which can be placed around the base of the Christmas tree or elsewhere to provide a great deal of fun; besides it shows the operating principles of the real scenic railways to be found at all large summer resorts. The mechanical details are practically few and quite simple. The track may be an ordinary toy railway track or else it may be home-made from wooden L-shaped strips. The cars are small toy railway cars or else a number of low-priced tin automobiles to be found at toy shops, which are afterward adapted to the purpose of the present venture.

The cars are hauled up the main and highest grade by a moving belt or bicycle chain fitted with projecting clips, as shown clearly in the diagrams, and as the cars reach the top of this first and highest incline, they dash down the other side by their own gravitation. If the length of the track is properly proportioned, with not too many humps put into it, the car will complete the circuit of the track and return to the position of the "pick-up" belt or chain at the base of the incline. This pick-up chain acts as a feeder for that passing up the incline—the same as in the large-size scenic railway.

It may be found that the cars will have to be weighted with some lead in order to make them heavy enough to stay on the track as they speed down the incline and around over the circular track. The front of each car has a piece of tin secured or riveted to it so as to hang downward in order to be engaged by the clips or lugs on the moving chain. A chain in this case is used instead of a flat belt.

EVERYTHING You want to know About A. C. Motors and Repairing

Whenever any question arises regarding motors, or if you are anxious to become a specialist on electrical motor work, you need the

ELECTRICAL WORKERS FRIEND

An invaluable collection of diagrams and instructions for electrical workers, students, amateurs, etc.

This book contains 86 motor diagrams with complete instructions for rewinding and reconnecting A. C. Motors. Shows how to put each coil in the slots, giving all internal and external connections. For reconnecting they cover all practical changes showing which diagram to use for the change wanted.

Bound in loose leaf form for

handy reference. The only complete book of its kind on the market. So simple anyone can understand. It is helping thousands of other workers—it will help you too, as hundreds of testimonials prove.

SPECIAL PRICE, COMPLETE \$4.00. Order today. If desired we will ship C.O.D. by Parcel Post.

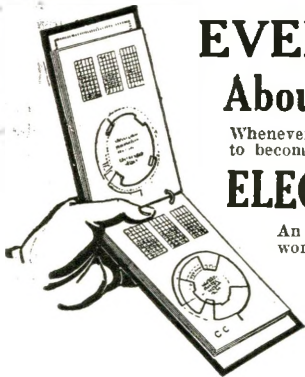

YOU CAN EARN YOUR COPY FREE

We offer all owners of the Electrical Workers Friend a commission of 50c on every book they help us sell. All you have to do is show your book and recommend it. You can earn the full price of one of these books in a few days. Write immediately for full particulars—this offer is limited.

SMITH & SMITH PUB. CO.

1524 Lowrie St., N. S. Dept. B, Pittsburgh, Pa.

10c CHARGES YOUR BATTERY AT HOME WITH AN F-F BATTERY BOOSTER IT PAYS BIG

or Magnetic Rectifier for 110-120 Volt 60 Cycle Alternating Current.

- | | |
|---|--|
| Bantam type 6-6 ampere 6 volt battery...\$15 | Bantam type 12-5 ampere 12 volt battery...\$20 |
| Type 16-8 ampere 6 volt battery..... 24 | Type 112-6 ampere 12 volt battery.... 24 |
| Type 166-12 ampere 6 volt battery.... 32 | Type 1612-7 ampere 12 volt battery.... 32 |
| Type 1626-12 or 7 amperes in combination for both 6 and 12 volt batteries..... 48 | |

F-F Battery Boosters are entirely automatic in operation. Screw the plug in lamp socket in your garage, snap charging clips on battery terminals without disconnecting or removing battery from car, turn switch and lock garage door, knowing your battery will be charged in the morning. You do not forego the use of your car for a single day. High charging rates are best for large batteries, or where time is limited. Shipping weight complete with **AMMETER and BATTERY CLIPS**, 11 to 15 pounds. Include postage and insurance with remittance for parcel post shipment. Keeping your Starting Storage Battery in charged condition makes it delightfully responsive and last longer, requiring fewer expensive battery renewals. Other F-F Battery Boosters for Farm Lighting Plants and Direct Current.

Battery Stations and Garages Use the F-F Rotary Rectifier for Group Charging.

SEND FOR BULLETIN NO. 12 NOW, IF NOT YET READY TO ORDER

THE FRANCE MANUFACTURING CO., 10321 Berea Road, Cleveland, Ohio

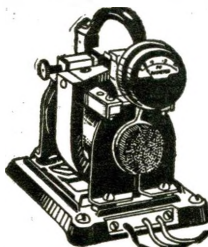

LEARN WIRELESS At Home By Mail

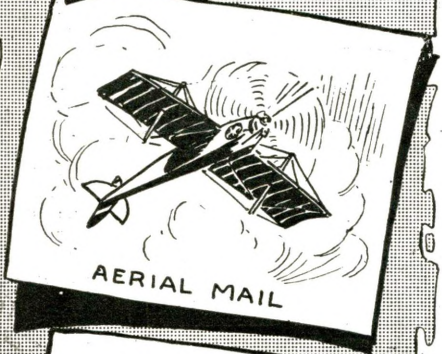
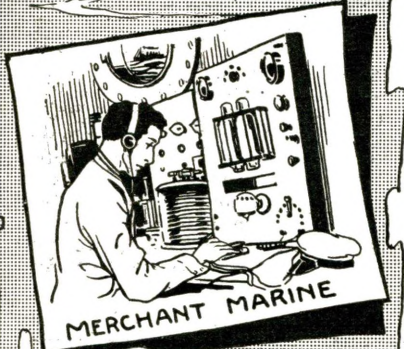

Calls Coming In Steadily For National Radio Institute Graduates. Big Concerns in Need of Operators.

MANY attractive positions are now open in Commercial Land Radio Service Merchant Marine, Radio Supply Factories, Lake and Ocean Steamship Lines, Telegraph Companies, and U. S. Shipping Board. We are continually receiving requests for more National Radio Institute Graduates than we can furnish.

Salaries up to \$3,500 a Year

Exceptional opportunity for ambitious men for promotion to the higher branches of Radio. You can learn Wireless the National Radio Institute way, quickly and easily, by mail right in your own home in your spare time. No previous experience or training is necessary. With our help you can quickly qualify for a First Grade Government License, and a good position. Our graduates are qualified as Senior Operators and start with a salary of \$125 a month, besides Room and Board, which when totaled and added to salary, means more than \$200 a month. One of our recent graduates is getting \$6,000 a year.

U. S. Department of Commerce Recognizes N. R. I. Graduates

and allows them a credit of 5 to 10 points when taking examination for First Grade Government License. This school heads the printed list of reputable Wireless Schools recommended by the U. S. Shipping Board.

Travel without Expense

If you are eager to travel, anxious to visit foreign countries and increase your knowledge of world affairs, Wireless offers you the chance of a lifetime. On shipboard you are rated as an officer, living and eating with the officers. However, you are not obliged to travel, if you secure a position at one of the land radio offices which are steadily increasing in number.

Pay as You Learn

Our plans of payment place a Wireless education within the reach of anyone who desires to learn. A small payment down, and the small payments made during the course, make it possible for you to earn the cost of your tuition while actually learning to be a Wireless operator.

Instruments Furnished Free

In addition to all necessary text books and other equipment with which we supply you, we furnish FREE to every student our new automatic Natrometer, which transmits Wireless messages in 600 different combinations. You receive the instrument after your enrollment; it becomes your personal property upon completion of our course.

The Natrometer automatically sends you messages in International Code, just as though they were coming to you through the air from a station a thousand miles away! The instrument is operated entirely without the use of aerials and can be regulated to any speed from 1 to 30 words a minute.

FREE. In addition to our complete course in Radio Telegraphy, every student is given our complete course in modern Radio Telephony. These combined courses enable our students to fill positions requiring a knowledge of both Radio Telegraphy and Telephony.

Send the following coupon today for our FREE BOOK containing all particulars.

MAIL THIS COUPON TODAY

NATIONAL RADIO INSTITUTE,
Dept. 385, Washington, D. C.

Send me your FREE book, "Wireless The Opportunity of Today." Tell me about your Home Study Course in Wireless Telegraphy and Telephony—the free post-graduate course—and your Special Instrument offer.

Name.....

Address.....

City.....State.....

Voice Thrower 10c
 Learn to throw your voice into a TRUNK, under the bed, out in the hall or anywhere. Lots of FUN fooling the Teacher, Janitor, Policeman, Parents, Neighbors, or Friends.



THE VENTRILO
 is a little instrument that fits into the mouth out of sight. BOYS or GIRLS can use it in conjunction with the above for imitating birds and animals. Never fails. A 32-page book on Ventriloquism sent with the Ventrilo for 10 cents.

NEW FORD JOKE BOOK 1920
 All the latest jokes on the Ford auto. Hundreds of them, and all good ones. Spring a new one on your neighbors. Large book with cover by mail, 10c



ROGEN X-RAY
Price 12 cents
 HERE, BOYS, is just what you want. With this instrument you can apparently see the bones in your fingers. Think of the fun you can have with it. Sample by mail, TWELVE CENTS.



SKULL RING
 Here is a handsome, up-to-date Ring, representing a Skull and Cross-bones. Has stones in the eyes and looks something frightful. Women won't like it, but for men or boys it is a great novelty. Sample, by mail, 20c.



Gee! What a Wad!
 This is **STAGE MONEY** Looks like the GENUINE STUFF. Some Green backs and some Yellow backs. Create a BIG sensation among your friends. The girls will all be after you when they see the wad. BIG roll of 15 pieces by mail, 10 cents.



ENCHANTED BARREL
 The Most Wonderful Pocket Trick Made
CHANGE A CENT INTO A DIME
 Ask your friend to drop a dime in the barrel. When he takes it out, Behold! It is a CENT. You make 9 cents every time you fool them. Never fails. They cannot get on to it. Sample barrel, with directions, only.... 12c



BIG VALUE for 10 Cts.
 6 Songs, words and music; 25 Pictures Pretty Girls; 40 Ways to Make Money; 1 Magic Book; 1 Book Letter Writing; 1 Dream Book and Fortune Teller; 1 Cook Book; 1 Baseball Book, giving rules for games; 1 Toy Maker Book; Language of Flowers; 1 Morse Telegraph Alphabet; 12 Chemical Experiments; Magic Age Table; Great North Pole Game; 100 Conundrums; 5 Puzzles; 12 Games; 30 Verses for Autograph Albums. All the above by mail for 10c.
 Any of the above Mailed with Catalog



ROYAL NOVELTY COMPANY
 486 East Ave. South Norwalk, Conn.

ENINGER WILL SAVE
BIG MONEY SAVINGS FOR YOU
 Used and rebuilt motorcycles, single and twins; \$25 to \$100. Used bicycles, \$5.00; tandems, \$10. All machines guaranteed in good working order. New bicycles and motorcycles at Factory prices. You save dealers' profits. Motorcycle and automobile tires too, \$3.00. Complete line of parts and supplies.
 Send for catalog Eninger Cycle Co., Rochester, N.Y.
YOU 25 TO 50 DOLLARS



New 400 Candle Power Lamp
 Gives a soft, brilliant, glowing light; restful to the eyes; an ideal illumination.
BURNS 96 PER CENT AIR
 200 times brighter than kerosene lamps. Burns 96% air and 4% common gasoline. Lamps and Lanterns for every purpose. Clean-odorless-economical.
ABSOLUTELY SAFE
 Can be carried anywhere—perfectly safe, even if tipped over.
LIGHTS WITH ONE MATCH
 New patented twin mantle burner lights with One Match easily and quickly. Greatest improvement of the age.
 SEND NO Write for Catalog, Special MONEY Agents' Offer, also Money-back Trial Offer. Write today.
THE AKRON LAMP CO.
 1172 Lamp Bld. Akron, O.



Lamp Facts for the Householder
 (Continued from page 853)

bulb is the governing factor, are these: The "S" or straight side bulb, having a hemispherical bowl and tapering, straight sides; the "G" or globular bulb, which is spherical; the "PS" or pear-shaped bulb of Mazda "C" lamps, similar in shape to the Bartlett pear; the flat-end bulb, used in flashlight lamps; the decorative flame bulb and the sweet-potato bulb.

Large Mazda "C" lamps are sometimes used for residence lighting, in which lower wattage Mazda "B" lamps should be used. And lower wattage Mazda "B" lamps are sometimes wrongly used in offices and factories where the larger Mazda "C" lamps ought to be employed.

Sometimes the particular problems peculiar to each specific case constitute a large factor in this tendency. But more commonly two misconceptions on the lighting question are the cause of such a situation. People do not realize the injury that is possible to the eyes under faulty lighting facilities. They also do not appreciate how economical it is to use the correct type of lamp.

THE LIFE OF AN INCANDESCENT LAMP.

There is an erroneous impression that a lamp possessing an extreme long life is the most desirable lamp to use. But when it is understood that the current consumed by a 25 watt lamp in one thousand hours is worth, at 10 cents per kilowatt hour, about \$2.50, while the lamp itself is worth less than one-fifth of that sum, it will be seen that the cost of the lamp is a small item in the total cost of lighting. It will also be, at once, perceived that it is an expensive economy to sacrifice light, merely to prolong the life of the lamp.

The average life of the lamps most commonly used is *one thousand hours*. They are designed to give service for that number of hours. That amounts to about *eighteen months* of use in the case of a lamp in a residence, assuming that it is burned on an average of about two hours out of every twenty-four.

Mathematical calculations have set up the one-thousand hour period as the longest for efficiency and economy. It would be possible to make lamps at a low efficiency, thereby increasing the life of the lamp. But that would also increase the current consumed per candle-power. On the other hand, by increasing the efficiency of the lamp, a decrease is effected in its life and in the current consumed per candle-power.

The most economical way of using incandescent lamps is, first, to install the smallest size of lamp that will give sufficient light for the purpose; and, second to operate the lamp at the voltage on the label, or even at a voltage slightly higher than that called for on the label.

As a 1 per cent increase in the voltage increases the watts consumed only 2 per cent, but increases the volume of light 5 1/2 per cent, such an operation as that mentioned is "good business"—even tho it tends to shorten the life of the lamp.

POINTED PARAGRAPHS ON "LAMPOLGY"

Speaking of the arithmetic of incandescent lamps and house lighting bills, there are a few points easily remembered by Mr. and Mrs. Householder, and the most important of these are cited below by the Editors:

To find the watts consumed by all the lamps in a house or other building, multiply the number of watts consumed by one lamp, by the number of lamps. Also, watts equals the volts multiplied by the amperes. Also, volts equals the resistance of the lamp multiplied by the current passing thru it; cur-

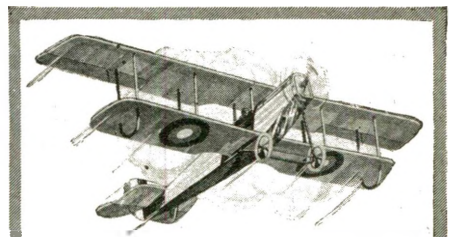

Building and Flying Model Aeroplanes
Real Fun for Live Boys!

BUILDING a Model Aeroplane is very interesting work for any boy. It develops his mechanical ability, keeps him busy and fascinated, and shows him many things about Aeroplane construction. Any boy can be proud of a completed Model Aeroplane, and have an exciting time flying it. Building is easy for any handy boy. IDEAL Model Aeroplane Construction Outfits contain everything needed to build a Model Aeroplane that is an exact duplicate of a real machine; also Complete Plans and full instructions. IDEAL Model Aeroplanes are guaranteed to fly when correctly built. Complete Construction Outfits may be had for building any of these well-known Aeroplanes.

Curtiss JN4-D2 Training Plane, 3-ft. Model (shown above).....	\$8.00
De Havilland Battle Plane, 3-ft. Model.....	8.50
NC-4 Naval-Curtiss Seaplane, 4 1/2-ft. Model.....	10.00
Curtiss Military Tractor, 3-ft. Model.....	7.50
Bleriot Monoplane, 3-ft. Model.....	6.00
Nieuport Monoplane, 3-ft. Model.....	7.00
Taube Monoplane, 3-ft. Model.....	5.50

West of Denver, Colo., and in Canada, 50c. extra for each outfit

These Complete Construction Outfits are sold in sealed boxes by the Leading Toy, Sporting Goods and Department Stores. Ask for them at your store. If your store hasn't them, we will fill your order direct, postpaid, upon receipt of price above, and guarantee satisfaction or money back.

Plans for Modern Aeroplanes

Complete Plans, which include Scale Drawings and Building and Flying Instructions, for any of the above Model Aeroplanes will be sent by mail, postpaid, for 35 cents. These Plans show exactly what is required to build a Model Aeroplane, and how to build it.

Send 5 Cents for Aeroplane Book

Gives full descriptions of all IDEAL Model Aeroplanes, Racing Aeroplanes and Flying Toys. Also lists hundreds of Model Aeroplane parts and supplies. It's a book every Amateur should have. Sent postpaid for 5 cents. Send for one today.



IDEAL AIRPLANE & SUPPLY COMPANY
 159-161 Wooster Street, Corner W. Houston Street, New York City

BIG PROFITS for YOU
 in **HB BATTERY CHARGING**

Profits of \$100 to \$300 a month are easy—hundreds of HB users make that, and more. You can, too. Cost 4c to 12c per battery—customer pays 75c to \$2.00. Start NOW—when winter brings biggest battery charging profits.

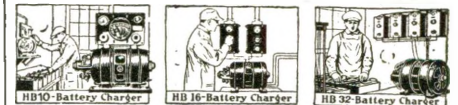

Mark a cross (X) on the outfit suited to your needs. Then tear out this ad and mail TODAY for complete information. Small cash payment—balance easy monthly terms. Get busy.

HOBART BROTHERS COMPANY
 Box 127E Troy, Ohio

INSYDE TYRES
 Inner Armor for auto tires. Prevent blowouts and punctures. Double tire mileage. Easily applied to any tire between casing and tube. Details free. Agents wanted. Liberal profits. Amer. Access. Co. Dept. T-1972 Cincinnati, O.



Learn Watchwork, Jewelrywork and Engraving
 A fine trade commanding a good salary, and your services are always in demand. Address HOROLOGICAL Department, Bradley Institute, Peoria, Ill., for our latest catalog.

rent equals volts divided by the resistance; while resistance equals volts divided by current.

The practically obsolete carbon filament incandescent lamp consumes from 3.1 to 3.5 watts per candle-power (C.P.), while the highly efficient tungsten lamp of the present day, consumes approximately one watt per C.P. while nitrogen lamps consume from $\frac{3}{4}$ watt per C.P. in the smaller size of about 100 C.P. value, down to as low as .6 watt per C.P. in the larger size bulbs, such as the 1,000 C.P. unit.

The accompanying illustration shows several practical ideas of value to people who are striving to economize in their electric light bills. It may be said as a foreword, that it does not pay to reduce the candle-power down to too low a value, as this means a strain on the eyes, which condition, of course, none of us desire to create or work under, but there are many ways in which the candle-power and the resulting wattage consumed in a given house or room can be conserved. Of course, if you desire artistic effects such as placing high candle-powered lamps inside of darkly colored glass shades made to imitate a bunch of grapes, and what not, and providing you are quite willing to pay the extra cost for this artistic effect on your monthly lighting bill, then this does not apply to you.

The sectional view of a typical house and electric lighting layout with the lamp watts marked in each room, is shown in the illustration. Another figure shows an expensive and also an inexpensive method of lighting up porches, even large size ones. Another figure shows the cheap way and the H. C. L. way of lighting the dining room, no matter whether large or small. Indirect lighting is a fine thing for those who wish to pay for the extra watts consumed, which amounts to about double that required with plain lighting of the dome variety, using for example, with the average size dome—a 40, 60 or 80 watt tungsten lamp with a half-frosted bulb.

In parlor fixtures, many people endeavor to economize by using one large unit such as 100 C.P. lamp in one receptacle of a three outlet fixture. Generally speaking, it is far preferable to employ three low C.P. lamps, such as 25 C.P. units, instead of using the one high-powered lamp. Three 25-watt lamps give a total consumption for the fixture of about 75 watts, and the lighting effect is usually vastly more even and agreeable all around.

There are three principal types of economizers for users of incandescent lamps, all of which are shown in one of the accompanying figures. One of these economizer receptacles or attachments dims the lamp by means of a choke coil or rheostat, when a cord depending from the socket is pulled. Another one operates by pulling one of two depending cord switches, switching on either a small low C.P. filament or a large high C.P. filament. Still another employs a small two coil A.C. transformer in an attachment plug which fits into any standard socket, in the base of which a small A.C. night lamp may be screwed.

All of these devices will save considerable money indeed, for those who have to burn a light all night in children's rooms, etc., or for those who need a regulating lamp for a photographic dark room, etc.

BUYING RECORDS BY TELEPHONE.

"Call 1-4-9-2-5 from your home and ask to hear any record you like. The service is complimentary." This is the way a Los Angeles store interests the public in buying talking machine records, as told by N. D. Dunlea in *System*. When you can hear new records so easily it is a great inducement to buy.

This plan, which has been inaugurated some two months, has been a great help.

LEARN DRAFTING

At Home—In Spare Time as you would in actual practice

Get into this constructive branch of industry where big salaries are paid. No previous training is necessary to become a capable draftsman with the help of the Columbia School of Drafting. You can master the practical lessons of our famous home study course, at home, in spare time. You will be personally coached and instructed, by mail, by Roy C. Clafin, president of the school, whose long experience as a draftsman and teacher, especially qualifies him to give you the training you need to become a successful Draftsman.

Become a Specialist

We not only give you thorough and practical training in Mechanical Drafting, teaching you to make actual drawings as you would in any drafting room, but the additional benefit of a post-graduate course in some special branch of drafting. A big field of opportunity is thus opened to you as a trained specialist in this profession.

Draftsmen are needed in greater numbers, and receive better salaries than ever before.



CHIEF ENGINEER \$2,000 TO \$5,000 A YEAR



CHIEF DRAFTSMAN \$50 TO \$150 A WEEK

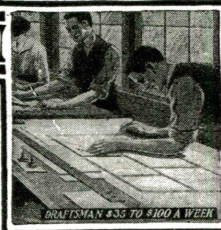

DRAFTSMAN \$35 TO \$100 A WEEK

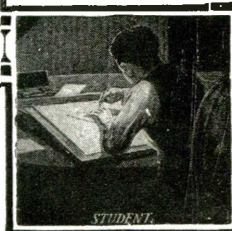

STUDENT

Draftsmen Get \$35 to \$100 a Week

Because of the importance of his work the draftsman is paid a big salary and is always in line for advancement. The draftsman's pay is from \$35 to \$100 a week. A knowledge of drafting is the stepping stone to big technical positions in the industrial field paying as high as \$50,000 a year.

How "Columbia" Students Succeed

Students of the Columbia School of Drafting often secure positions at \$2,000 or more a year to start before completing the course. Hundreds of men and women with "Columbia" training are now making good with big concerns all over the country. Many more are needed for splendid positions now open. Here is what "Columbia" training is doing for some of our graduates: Laurence Johnston, over \$5,000 a year; George Murray, \$45 a week to start; G. Tangorra, \$2,800 a year; A. L. Gash, \$140 a month to start; W. S. Burfoot, \$150 a month to start; T. R. Brown, \$2,860 a year; R. Fowkes, \$3,700 a year. These are only a few of a great number of similar cases.

Big Concerns Employ "Columbia" Graduates

The best concerns in America employ Columbia graduates in their drafting departments because of the thorough practical training we give which enables them to step right into important drafting positions. Our diploma is the entering wedge into big drafting rooms everywhere. As a Columbia graduate you are recognized as an experienced draftsman, not as a mere apprentice. Why be satisfied with a grinding, underpaid position when there are hundreds of promising positions open to you in the big field of Drafting. We are called upon to place trained draftsmen more rapidly than we can produce them.

Send This Coupon Today

Let us tell you the fascinating story of Drafting and how you can master this lucrative profession of big salaries and steady advancement through our help. Write today to

COLUMBIA SCHOOL OF DRAFTING

Roy C. Clafin, President
Dept. 1241, 14th & T Sts., N. W., Washington, D. C.

This Complete Drafting Equipment Furnished

to students of our school. The instruments are of standard American make of the best quality, fully guaranteed, and become your property on completion of the course. Every instrument needed for the course is included.

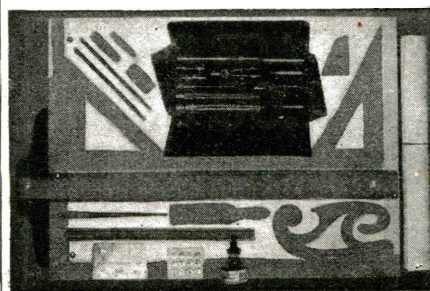

COLUMBIA SCHOOL OF DRAFTING,
Dept. 1241, 14th and T Sts., N. W.,
Washington, D. C.

Without obligation to me, please send me FREE your illustrated book of particulars, testimonials from students, rates and liberal terms.

Name
Age Address
City..... State.....

Be a Movie King

OH BOY! SOME SPORT
Surprise the Bunch—Have a Barrel O' Fun

Own a Genuine Moving Picture Machine

Here's what you've always wanted—a genuine MOVING PICTURE MACHINE—a machine that uses STANDARD FILM—like the Big theatres show—at a price you can easily afford to pay. This is the BIG opportunity—don't MISS it. Read every word, then act quick. Three swell models to select from. Each the best of its kind. All REAL moving picture machines—not toys or magic lanterns, but REAL Movie Machines, that show the pictures on the screen. The Films are supplied to us by the leading film companies in America, and the subjects include all the LEADING actors and actresses that you see and admire in all the big theatres. The "fellers" and girls and the grown-ups, too, will sit spellbound, or roar with laughter at the wonderful, lifelike, real movies you can show them.



Three-Reel Cinematograph

Here is an astonishing bargain. Our latest Model Cinematograph is a whirlwind value. At the price it has everything you ever heard of. Here is a genuine Moving Picture Machine, made entirely of metal, solidly constructed, and put together by expert workmen, that you can buy at a price that will simply astound you. It comes equipped with a SAFETY CARBIDE Gas Generator, and can be used to show moving pictures anywhere. The mechanism is so simple it can be operated by anyone. The greatest value in a Genuine Moving Picture Machine ever offered at the price of it!

A genuine Moving Picture Machine, using STANDARD FILMS, shipped by express, charges collect, with 3 REELS FREE, for ONLY \$3.00; or shipped by parcel post to any address in the world prepaid for \$3.25.



\$3.00

New Model Movie Machine

Your Choice of Gas or Electric Light

This is a beautiful, high-class Moving Picture Machine. Made of sheet iron with wood base. Finished in black or battleship grey with handsome red stripe trimmings. Solid and substantial construction. Size 12x7 1/2 x 5 1/2 in. Uses STANDARD FILM same as the big machines. TWO TYPES—Electric and Gas. The electric machine is equipped with plug and cord complete, ready to attach to any electric light socket. Gas machine has its own generator and makes its own light. The gas machine can be used anywhere and will be sent unless electric type machine is specially ordered. Sent securely packed in special shipping case with full instructions. Film, supply of show tickets, etc., for \$7.50 by express, or \$8.00 if sent by prepaid parcel post.



Price \$7.50
Gas or Electric

Keystone Moviegraph

Moving Picture and Magic Lantern Combined

A regular beauty, all complete, ready for you to use the minute it arrives. Hang up a sheet, put on a reel, turn the crank, and you're off. That's all there is to it. Made of metal throughout, with heavy base casting. Finely adjusted mechanism, easily operated. Electric model only, simply screw in plug to your electric light socket and you are all ready for an exhibit. Equipped to show slides as well as Real Moving Pictures—just like the big machines. 12 1/2 x 7 1/2 in. Comes with 3 EXTRA LONG STANDARD SIZED FILMS, 3 FINE LANTERN SLIDES, and admission tickets—all FREE. A machine you will be proud of. You can have endless fun and amusement, and MAKE MONEY with it. Sent by express, with full instructions and extra long cord and plug, securely packed, for \$12.00; or by parcel post, to any address in the world, for 75c extra.



Price \$12.00
A Beauty

No. 2 Rewind Model

Largest and Most Powerful Model

This is the No. 2 Rewind Model, with equipment for unwinding and rewinding 100 to 200 feet of film. The size of the machine is 6 1/2 x 14 x 19 inches. It is constructed on a wooden base 6 1/2 x 11 1/2 inches, which will not scratch the furniture. Electric model only, it operates from any electric lighting circuit. All you have to do is screw in plug to any electric light socket. It has a regulator so that different sized lamps may be used—electric socket, plug and six feet electric lamp wire cord, and nickelled reflector. Also shows magic lantern slides. With this machine we furnish a can of 100 feet of film, three American-made Lantern Slides—subjects of which are Wilson, Pershing, Aeroplanes, Boy Scouts, Charlie Chaplin, Jiggs, Comics, etc., 100 Theatre Tickets, guarantee and full directions. PRICE \$20.00, shipped by Express, or by prepaid parcel post to any address in the world for \$1.00 extra.



REWIND MODEL \$20.00

Extra Films

EXTRA FILMS. For all our Machines. Big variety of subjects, including leading and best known movie actors and actresses. Standard size. Short Reels, Price 15 cents each. Extra Long (5 feet). Price 3 for \$1.00. Special 100-foot reels \$2.50 each. CHARLIE CHAPLIN FILMS, 25c each; 5-foot lengths, 60c each. All postpaid.

LANTERN SLIDES for Keystone Moviegraph, American made, 6 for 75 cents. "U-MAK-EM" SLIDES. A special slide for use with the \$12.00 and \$20.00 machine or any other machine with Lantern Slide equipment, for showing on the screen advertisements, etc. Can be used repeatedly. PRICE 3 for 50 cents postpaid.

JOHNSON SMITH & CO., Dept. P.M.35 3224 N. HALSTED ST., CHICAGO



ACHROMATIC TELESCOPE MADE UPON NEW SCIENTIFIC PRINCIPLES.

Positively such a good Telescope was never sold for this price before. Eastern Telescopes are made by one of the largest manufacturers of telescopes in America; we control entire production; measure closed 8 inches and open over 2 1/2 feet in 4 sections. They are nicely brass bound, with scientifically ground lenses. Guaranteed by the maker. Every sojourner in the country or at the seaside resorts should certainly secure one of these instruments, and no farmer should be without one. The scenery just now is beautiful. A Telescope will aid you in taking views. Objects are brought to view with astonishing clearness. Sent by mail or express, safely packed, prepaid, for only 99 cents. Our new Catalogue of Watches, etc., sent with each order. This is a grand offer and you should not miss it. We warrant each telescope just as represented or money refunded. Send 99 cents today. To dealers 6 for Four Dollars.
EASTERN NOVELTY CO., DEPT. 67. 172 E. 93d STREET, NEW YORK.

The ACE RAZOR

\$1.00 POSTPAID ANYWHERE

Combined straight and safety razor in one, detachable guard (not shown in cut) permits of use either as straight or safety. Neatly finished, black enamelled long handle, detachable blades of finest selected steel, good for 4 months' use. Instantly cleaned. The old-fashioned clean shave and the new-fashioned safety shave in one. Send for yours today, postpaid, anywhere. Money refunded after 10 days if not satisfactory.

Raymond Farrell Co., Dept. 22, 3256 Third Avenue, New York

The First Practical A. C. Dynamo

(Continued from page 857)

and current capacity in the ratio of 1 to 4. At the opposite end of the armature from that shown, and beyond the connection board, is the commutator, consisting of four half circles arranged in two rings, one ring for each armature coil. On these the brushes rested and the two commutators were connected in series, commutating thus a biphasic current, to obtain continuous current. The chief use of this dynamo was to run an arc light; and in so doing it probably absorbed about three horse power. The armature core, on account of the difficulty of getting sheet iron plates (by no means a small difficulty in those early days) was made by assembling a number of thin, soft castings.

The machine was capable of being used as an alternating current generator, giving bi-phase current or current displaced 90 degrees in phase, one alternating current coming from one of the armature coils, and the other coming from the coils at right angles thereto. Experiments were made with the alternating currents supplied by this early machine, and it is a noticeable fact in this connection that this machine was used to supply, early in 1879, from its alternating current side, transformers; and was shown supplying two shell-type transformers, the primaries or fine wire coils of which were connected in parallel to the source of line from the machine; and the secondaries were run individually as course wire secondaries working whatever might be at hand as a load, such as small vibrating arc lamps, resistance wires, etc. The question may arise: Why not have used incandescent lamps? Well, there were not any in those days. It was nearly a year before Edison had produced any of the carbonized paper filament lamps; and nothing of an equivalent character was available. The machine was first operated at the Franklin Institute building in Philadelphia, where there was, back of the lecture platform, a six-horse power engine of a single-cylinder, upright type. Power was by no means so easily obtained in those days as today. There were no such things as gasoline or oil engines, and even gas engines were somewhat rare. This historic and early American built dynamo is in the collection of the General Electric Company at the Lynn works, to which company we are indebted for the photograph and interesting diagram of circuits taken from the early personal notes of Prof. Elihu Thomson. This article was written by Prof. Thomson himself.

The Amateur Magician

By JOSEPH H. KRAUS

(Continued from page 870)

to one of these metal bands. The other band connects with a lead from the solenoid. The method of closing the circuit is identical with the roulette wheel described, I believe in my last discourse, and consists in making and breaking the circuit with a ring upon any finger. This arrangement is never noticed and does not generally allow meddlesome people to discover this secret. "Is that clear?" I assured him that it was, and then asked, "But how about the wand when you gave it to me and how about the coins falling into the hat; surely there is some palmistry or some slight-of-hand work?"

"Not at all, was his answer. You see I simply held the cap or cover of the end in my hand and when I presented you with the wand, I transferred the wand from one hand into the other, slipping the cap in place. On the inside of this cap is soldered half of a snap cuff-link or similar snap fastener, in the wand proper is inserted the female part, and when the wand is given to any person, this simple snap holds the end in place quite securely, as you can readily see from the diagram."

"But the coins in the hat," I interrupted, "I am sure I heard them fall."

"I wouldn't swear to that if I were you," he added, "as the reason I asked for a high hat is because it makes plenty of noise and the effect of dropping a coin into the hat was obtained by merely snapping my finger against the brim."

"Oh!"—was all I could say.

After having recovered from the effects of this, I said "These tricks are wonderful, Professor, but haven't you anything in your encyclopedia which doesn't need the preparation or the instruments which you have employed thus far? Some simple trick for every reader to perform." "Well, let me see—I believe I have. Wait a few moments."

I busied myself with a magazine which he had lying on the table, when, a short time later he returned with colored bits of paper, the ends of each strip were glued together making a loop about 4 ft. long and 1/2 inch wide. Throwing these upon the table he drew out a pair of shears and said to me, "Are you a good tailor? Insert these scissors here and cut all around the loop." It was a tedious operation but soon finished, and as a result I gave him *two* loops. Immediately he flared up. "What did you do that for. I told you to cut all around them but did not say to make two loops out of it. One was sufficient, and then you even separate the loops, you should be taught how to cut." I was quite amazed at this sudden turn of affairs and then gradually becoming more bold, I demanded that he do better. Picking another of the strips he commenced cutting it the same way I had done. "Now if you had coaxed it along, you might have done better or perhaps if you had spoken some magic word over it and made a pass,—thus a word like consologalecotpitalianthropohagenarianism, would have benefited your trick immensely." He had completed the cut and there were the two loops interlinked. Picking up another sheet of paper he said "Maybe I can do better this time," and when he had finished cutting this, he had one loop left. Yes, to be sure I was not under the effects of no "half of no per cent liquor." He had actually cut a loop in half, and after cutting it showed me one loop *twice the size of the original one!*

"Now I'll try once more," he said, and picking up the last loop of paper started to cut this. This was completed in a few moments and there he was with a loop of paper which had a knot in it. Which of these two stunts were the more remarkable is more than I could tell, but there to be sure was the mute evidence lying in front of me.

Hargrave laughed merrily at my chagrin, then gave me this secret. "You see old topper, the loop I gave you was unprepared. Those I had, I prepared and the preparation needed is very simple. The first loop is made so that it doesn't contain any twist in the paper. This you cut in half and try as hard as you will you cannot obtain anything but two separated loops from the paper. The second loop is made by gluing the two strips together but prior to gluing, the paper band is given a half twist, the third two half twists and the fourth loop three half twists. These twists are never noticed in a narrow long band of paper, and the surprise of the cutting doesn't abate sufficiently to allow the onlooker to notice the double twist or the triple twist described. Try it when you get home." With that he ushered me from the room.

Learn Electricity This Wonderful New Quick Way

At Home in Your Spare Time

EVERY year hundreds of young men from all over the world come to the residence school of the

School of Engineering of Milwaukee to learn electricity in all its phases. Yet we know that there are thousands of ambitious men everywhere who aspire to big jobs in the great field of electricity, but who cannot conveniently leave their present work to attend a residence school. It is to train these men that this extension division has been formed.

We knew from our long experience that the ordinary plan of teaching electricity by home-study methods would not measure up to the high standards set by the School of Engineering of Milwaukee. And so, this unique, new plan of giving each student free use of a complete home-laboratory system of actual working electrical equipment was conceived. We know that it is the only practical way to learn electricity at home!

America's Greatest Electrical School Brought to Your Home!

On this plan you can now secure almost every advantage of America's Greatest Institution of Electrical Education right in your own home! In this way this famous school now gives the most thorough practical intensive home-study course in electricity ever offered! It is a specialized, graded course built up on the most advanced ideas of electrical instruction. Thorough, yet simple texts—graphically illustrated give the electrical principles which logically parallel the practical experience gained in using the instrument boards. This amazing new method of extension instruction quickly makes any ambitious man a high-salaried, electrical expert!

Free Use of This Fine Electrical Apparatus

These wonderful, cleverly constructed instrument boards—equipped with actual, practical electrical apparatus—are furnished absolutely free to each student while studying. These laboratories are not toys—but include the same instruments and devices which

the electrical man meets with in every day work.

You Can Fill One of These Big Pay Jobs

The field of opportunity for the well trained electrical man is practically unlimited. Billions of dollars are invested in this great industry. Thousands of men are employed in it—but the demand today is for men who are *trained specialists*. These men command handsome salaries—\$2,500 to \$6,000 and up to \$10,000 a year and more. Why don't you get into this fascinating, highly paid field of work?

Write Quick for Big FREE Book

Write quick for big free book fully describing this astonishing new plan. Tells also about Consultation Privileges with our great staff of over 90 experts. Free Employment Bureau and other special service. Don't delay! Mail the coupon Now!

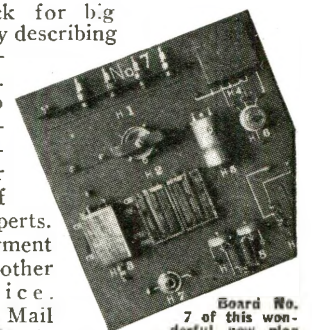

Board No. 7 of this wonderful new plan of studying electricity at home.

EXTENSION DIVISION
SCHOOL OF ENGINEERING
of Milwaukee
Dept. S-14, 373 Broadway, Milwaukee, Wisconsin

Extension Division
School of Engineering of Milwaukee,
Dept. S-14, 373 Broadway, Milwaukee, Wisconsin

Please send me free and without any obligation on my part full details of your special new home-study course in Practical Electricity.

Name
Address
City..... State.....
Age..... Education.....

**Just Like
Going to
School**

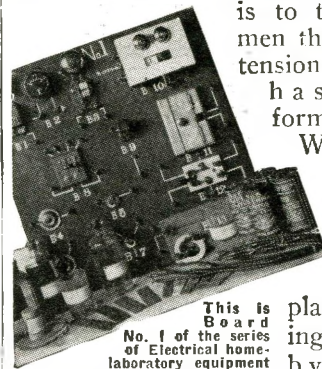

This is Board No. 1 of the series of Electrical home-laboratory equipment the free use of which is given every student. (Size 24 by 24 inches.)

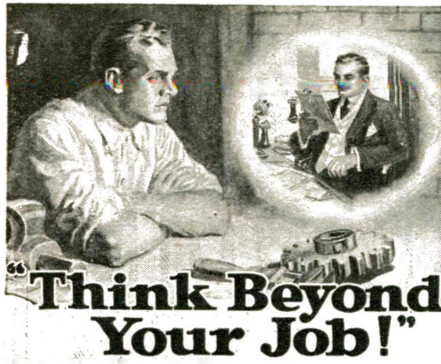

Think Beyond Your Job!

"There is not a man in power at the Bethlehem Steel Works today," says Charles M. Schwab, in the American Magazine, "who did not begin at the bottom and work his way up. Eight years ago Eugene Grace was switching engines. His ability to out-think his job, coupled with his sterling integrity, lifted him to the presidency of our corporation. Last year he earned more than a million dollars. . . . Jimmie Ward, one of our vice-presidents, used to be a stenographer. The fifteen men in charge of the plants were selected, not because of some startling stroke of genius, but because day in and day out they were thinking beyond their jobs."

If you want to be somebody, to climb to a position of responsibility, get ready for it. Do what you are doing now better than the men beside you, and train for the job ahead. You can do it—in spare time—through the International Correspondence Schools.

For 29 years men with ambition and I. C. S. help have been making spare hours the stepping-stones to successful careers. Last year more than 5,000 reported that their studies had won for them advancement and increased salaries. Over 130,000 men in offices, shops, stores, mines and mills and on railroads all over America are preparing in the I. C. S. way to take the next step upward.

Join them! All you need is just ordinary brains, the will to do, and the firm resolve to think ahead of the job you now hold. The I. C. S. are ready to make the rest easy. Make your start. Mark and mail this coupon.

TEAR OUT HERE

INTERNATIONAL CORRESPONDENCE SCHOOLS BOX 6171-B, SCRANTON, PA.

Explain, without obligating me, how I can qualify for the position, or in the subject, before which I mark X.

- | | |
|--|--|
| <input type="checkbox"/> ELECTRICAL ENGINEER | <input type="checkbox"/> CHEMICAL ENGINEER |
| <input type="checkbox"/> Electrician | <input type="checkbox"/> SALESMANSHIP |
| <input type="checkbox"/> Electric Wiring | <input type="checkbox"/> ADVERTISING MAN |
| <input type="checkbox"/> Electric Lighting | <input type="checkbox"/> Window Trimmer |
| <input type="checkbox"/> Electric Car Running | <input type="checkbox"/> Show Card Writer |
| <input type="checkbox"/> Heavy Electric Traction | <input type="checkbox"/> Outdoor Sign Painter |
| <input type="checkbox"/> Electrical Draftsman | <input type="checkbox"/> RAILROADER |
| <input type="checkbox"/> Electric Machine Designer | <input type="checkbox"/> ILLUSTRATOR |
| <input type="checkbox"/> Telegraph Expert | <input type="checkbox"/> DESIGNER |
| <input type="checkbox"/> Practical Telephony | <input type="checkbox"/> BUSINESS MANAGEMENT |
| <input type="checkbox"/> MECHANICAL ENGINEER | <input type="checkbox"/> Private Secretary |
| <input type="checkbox"/> Mechanical Draftsman | <input type="checkbox"/> BOOKKEEPER |
| <input type="checkbox"/> Ship Draftsman | <input type="checkbox"/> Stenographer and Typist |
| <input type="checkbox"/> Machine Shop Practice | <input type="checkbox"/> Cert. Pub. Accountant |
| <input type="checkbox"/> Toolmaker | <input type="checkbox"/> Traffic Management |
| <input type="checkbox"/> Gas Engineer | <input type="checkbox"/> Commercial Law |
| <input type="checkbox"/> CIVIL ENGINEER | <input type="checkbox"/> GOOD ENGLISH |
| <input type="checkbox"/> Surveying and Mapping | <input type="checkbox"/> STATIONARY ENGINEER |
| <input type="checkbox"/> MINE FOREMAN OR ENG'N'R | <input type="checkbox"/> CIVIL SERVICE |
| <input type="checkbox"/> ARCHITECT | <input type="checkbox"/> Railway Mail Clerk |
| <input type="checkbox"/> Architectural Draftsman | <input type="checkbox"/> Textile Overseer or Supt. |
| <input type="checkbox"/> PLUMBING and HEATING | <input type="checkbox"/> AGRICULTURE |
| <input type="checkbox"/> Sheet Metal Worker | <input type="checkbox"/> Poultry Raising |
| <input type="checkbox"/> Navigator | <input type="checkbox"/> Automobiles |
| | <input type="checkbox"/> Spanish |
| | <input type="checkbox"/> French |
| | <input type="checkbox"/> Italian |

Name _____

Present Occupation _____

Street and No. _____

City _____ State _____

Send No Money

Snap this bargain up right now before it is too late. Only limited quantity. Amazing underwear bargain. Greatest offer ever made. **Two Guaranteed \$4 Each, Wool Unionsuits \$5.75.**

Save big money on your underwear. Send postcard or letter today—this very minute, for these 2 beautiful perfect fitting heavy weight gray elastic rib unionsuits. Full cut. Seams reinforced and overcast. **Send No Money**—pay only \$5.75 on arrival, no more; we pay delivery charges.

We Guarantee to refund your money if you can match these 2 wonderful wool unionsuits for \$8.00. Order this amazing bargain this minute before it is too late. Just give name, address and breast measure.

BERNARD-HEWITT & COMPANY
Dept. U-3912 221 N. 1st Street, Erie, Pa.

Heat for the Household

By H. WINFIELD SECOR
(Continued from page 864)

of compressed coal dust, charcoal, and there has recently been quite a flutter among the fuel producers by the introduction of briquettes made from compressed sawdust, mixed with coal dust.

There was recently shown in this journal, a photograph of a new British built stove which was intended to be used with briquettes, as a source of fuel and which burned for eight hours on one loading. Americans are probably most familiar with briquette heating thru the introduction a generation ago, of the famous Clarke carriage and automobile stoves which employed a non-smokeless slow-burning briquette made in a special manner. Small pocket stoves burning briquettes containing a nitrate to accelerate combustion, have also been made from time to time, both in this country and abroad.

Electric Fans Boost Fuel Efficiency

It sounds quite paradoxical to think of using electric fans in the winter time when we are hugging radiators and stoves in order to keep warm, and yelling at little Johnny and Sister Sue to close the door in a hurry, for fear some of the precious heat may be lost. However, the new generation has listened wisely to heating engineers and knows that an electric fan, judiciously employed, will help the circulation of heated air in a room or building.

The illustration at Fig. 6 shows how to construct a very good air deflector so as to re-direct the incoming cold air from the raised window sash, to the electric fan placed behind the radiator, thus causing a constant current of heated air to pass thru the room. It is usually best, especially in offices, to have the top sash of the windows lowered a little so that a perfect circulation of air can take place. The cold air going in at the bottom of the window is heated by the radiator, and then rising to the top of the room, eventually passes out thru the open top of the window.

Another good use for electric fans is in relation to the furnace; sometimes, the electric fan is placed before the draft door to provide a forced draft and in other cases, fans have been placed with excellent results in the cold air intake box as shown, so as to promote a steady and sufficient draft of cold air into the furnace. Those who have had experience with hot air furnaces know that one of the great troubles with this type is that in sluggish weather, when there is not much wind, it is often very difficult to get the heater to throw a sufficient amount of hot air into the rooms heated by it. This is due to the fact that there is not a sufficient amount of cold air taken in thru the cold air box and the object of using a fan in establishing this condition, will be at once apparent.

Saving Coal With Storm Sash

It is surprising how few people realize that they can save as much as 40 per cent on their winter fuel bill by the judicious installation of extra glass windows or storm sashes on the outside of the window frames. People who live in city apartments or in well settled localities where the houses are fitted in like building blocks, do not notice this, of course, so much as where a house is swept by the "four winds of heaven." Once you have tried storm sashes on your east, north, or west windows you will marvel at their efficiency.

DEPENDABLE
KNAPP
ELECTRIC SPECIALTIES

LITTLE HUSTLER MOTOR

With New Starting Switch \$2.00

A powerful little motor that gives perfect satisfaction. Excellent workmanship throughout. Has a three-pole armature, causing the motor to start without assistance when the current is applied.

Equipped with pulley for running mechanical toys, models or driving a fan at high rate of speed.

AT ALL LIVE DEALERS

Insist on your dealer showing you the KNAPP line—KNAPP goods are best. If your dealer cannot supply you, order direct. Send for FREE illustrated catalogue showing a complete line of Electrical Motors and Novelties.

KNAPP ELECTRIC & NOVELTY CO.
523 West 51st Street, N. Y. City

Shoot Without Noise

Avoid disturbance, also finching. Enjoy quiet shooting anywhere, any time. Use the new Model 1920

MAXIM SILENCER

Price, .22 cal., \$7.00. Send 6c in stamps for catalog and BOOKLET of astonishing experiences of Silencer users.

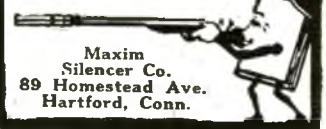

Maxim Silencer Co.
89 Homestead Ave.
Hartford, Conn.

9 TOYS all for 2c

To introduce our new catalogue of a thousand tricks and jokes, toys and novelties, we make this big bargain offer. For only a two cent stamp we will send you prepaid, 9 toys: a game of anagrams, the 1921 joke book, genuine dealomania transfer pictures, pictures to paint, a railroad cut-out (an engine, four cars, station signal and water tank), puzzle picture, check-board puzzle, the broken match trick and a mind reading trick. All yours for only a two cent stamp. Nothing more to pay.

Send 2c Today Write today and enclose a two cent stamp for 9 toys. We will send you our new catalog free. Write your name and address plainly. 200 South Peoria Street JOHN PLAIN & CO., Dept. 1259, Chicago, Ill.

PROFITS for YOU (Charging Batteries Making Electric Lights)

With the HB Lighting and Battery Charging Set you can make your own electric lights for as low as 2c per KW, and make a profit from \$100 to \$150 per month on battery charging. Anyone can easily operate without experience. Sturdy, dependable, economical to operate from line-shaft or your engine. **Makes big, easy profits.**

Small Payments Put This Money-Maker in Your Shop

Balance on easy terms. Profits pay for outfit. Absolute Money-Back Guarantee. Ask our Service Department about proper size for your needs. Pin this ad to your letterhead and write TODAY for information.

HOBART BROTHERS COMPANY
Box 128E Troy, Ohio
Successful Manufacturers since 1893

Model Electric Motor Boat



30 inches long. High power. Built like a real boat—\$15.00

Send stamp for illustrated lists of working model boats, engines, etc.

BATHE MANUFACTURING COMPANY
Deck 2, 5214 Woodland Avenue, Philadelphia, Pa.

LEARN WIRELESS AT HOME

The Demand for Good Wireless Operators Far Exceeds the Supply

The New York Wireless Institute will make you an operator—AT HOME—in your spare time—quickly, easily and thoroughly. No previous training or experience required. Our Home Study Course has been prepared by Mr. L. R. Krumm, formerly Chief Radio Inspector, Bureau of Navigation, N. Y. He resigned last August to accept a position of still greater responsibility with one of the largest Commercial Radio Corporations in the United States. Radio experts able to impart their practical and technical knowledge to YOU in an *easy to understand* way will direct your entire Course. The graded lessons mailed you will prove so fascinating that you will be eager for the next one. The instruments furnished *free* will make it as easy to learn the Code as it was to learn to talk. *All you will have to do is to listen.*

Big Salaries

Wireless operators receive excellent salaries ranging from \$125 to \$200 a month and it is only a stepping stone to better positions. There is practically no limit to your earning power. Men who but yesterday were Wireless Operators are now holding positions as Radio Engineers, Radio Inspectors, Radio Salesmen at salaries up to \$5000 a year.

Travel the World Over

A Wireless Operator can visit all parts of the world and receive fine pay and maintenance at the same time. Do you prefer a steady position without travel? There are many opportunities at the numerous land stations or with the Commercial Wireless or with the Steamship Companies.

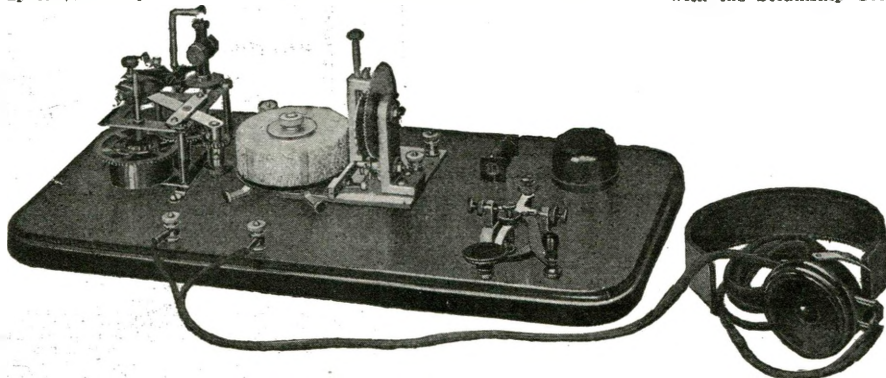

FREE Instruments and Text Books

We furnish free to all students, during the Course, the wonderful receiving and sending set exactly as shown in the illustration. This set is not loaned, but given to all students completing the Course. One cell of dry battery all that is required. No additional wiring, aerials, etc., needed.

This wonderful Set for learning the Code furnished free with our Course.

The Transmitter shown is the celebrated Omnigraph used by several Departments of the U. S. Government and by the leading Universities, Colleges, Technical and Telegraph Schools throughout the U. S. and Canada. Start the Omnigraph, place the phone to your ear and this remarkable invention will send you Wireless Messages, the same as though you were receiving them through the air, from a Wireless Station hundreds of miles away. When you apply for your license, the U. S. Government will test you with the Omnigraph—the same model Omnigraph as we furnish to our students. Ask any U. S. Radio Inspector to verify this.

Wireless Telephony Course

We have incorporated in our Institute an up-to-date and complete Course in Wireless Telephony, written by our Chief Instructor, Mr. L. R. Krumm. This Course is also furnished free.

FREE Post-Graduate Course

A one month's Post-Graduate Course, if you so desire, at one of the largest Wireless Schools in New York City. New York—the Wonder City—the largest port in the World and the Headquarters of every leading Wireless and Steamship Company.

The Department of Commerce of the U. S. Government

recognizing the value of the instruction furnished by us, allows all of our graduates a five-point credit in their examination for first-grade license.

THE U. S. SHIPPING BOARD will also testify as to the value of this instruction.

America's Fastest Growing Wireless Institute

There Must Be a Good Reason.
There Is—

- The Best Course in Theory available.
- The Best Instruments obtainable.
- The Best Text Books and Diagrams on the market.

Easy Payments

A small payment down will enroll you. We will make the payments so easy that anyone ambitious to enter the fastest growing profession—Wireless—may do so.

Send for FREE Booklet

Without obligating you in any way, send for our booklet "How to Become an Expert Wireless Operator"—it is free. Mail the coupon below, or postal or letter—but do it today.

NEW YORK WIRELESS INSTITUTE,
Dept. 77, 258 Broadway New York City

New York Wireless Institute

Dept. 77, 258 Broadway, N. Y. City.

Send me, free of charge, your booklet "How to Become an Expert Wireless Operator," containing full particulars of your Course, including your Free Instrument offer.

Name

Address

City or Town.....State.....

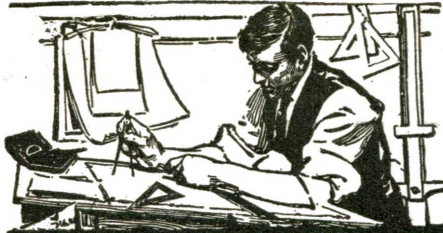

Be a Draftsman!
Make \$30 to \$75 a Week

Your name and address on the coupon brings this great Cyclopaedia of Drawing without a penny down. Pay only net shipping charges when books arrive. With these books and a low price "school set" of drawing instruments, obtainable at any store, a man can become master of drawing and earn \$30 to \$75 weekly.

LEARN AT HOME.—Good paying positions open everywhere. Intense activity in manufacturing, railroad, building, etc., calls for more draftsmen.

Shipped on 7 Days' FREE Trial
CYCLOPEDIA OF DRAWING

4 Volumes, 1650 Pages. Thousands of Illustrations. Bound in genuine American morocco. Pages 6 1/2 x 8 1/2 inches. Covers all branches of Drafting—Architecture, Electrical, Structural Steel, Sheet Metal, etc. Teaches pen-and-ink rendering, lettering, free-hand, perspective, shades and shadows, working shop drawings, machine design, etc., etc.

Only \$3 a month if you keep the books. Coupon explains offer, good only within borders of U. S. and Canada.

Free Membership in This Society.—A Consulting Membership given free with each set—worth \$12.00.

AMERICAN TECHNICAL SOCIETY
Dept. D-259 Chicago



AMERICAN TECHNICAL SOCIETY
Dept. D. 259
Chicago, U.S.A.

Please send Cyclopaedia of Drawing for 7 days' examination, shipping charges collect. I will send \$2.80 within 7 days and \$3 a month until \$19.80 is paid, or notify you and hold books subject to your order. Title not to pass until fully paid.

Name _____
Address _____
Reference _____



A SPECIAL

Factory
Cut Price
U. S. Officer's Shoes

Hand sewed, first-grade factory cut-down price. Direct to you at only **\$6.85**. Made of the best Water-proof Mahogany calf leather. If these shoes are not just as we say, send them back. You do not lose a cent. Retail price of this shoe is \$10.00. Built for work and dress at the same time. If you are sending money order or check do not include postage. Pay only for shoes. We pay postage.

U. S. Army
Marching Shoes

First-grade factory, cut down-price. Direct to you at only \$5.85. Retail price of these shoes is \$8.00. Made of the best elk skin waterproof leather. Second grade \$5.15.

U. S. NATIONAL MUNSON
ARMY SHOE CO., Inc.
Dept. 320
Westfield, Mass.

\$50.00 the First Week



"I have averaged \$50.00 a month ever since I started acting as your representative a year ago," writes Garrison. "I'm in one day," writes Lamar. Think of it. Thousands of agents all over the country are making big money representing us. You can too. Here is a bonafide proposition. Absolutely guaranteed in every way. The biggest money making offer ever given. Write at once.

Raincoat FREE

Yes, we will give you a splendid gray worsted water-proof top coat in the latest style—of fine material. Snug, smart belt—roomy patch pockets. Write in at once if you want this wonderful coat free, but don't wait. This offer is only open for a limited time. Write in now to

GOODYEAR MFG. CO.
Dept. 5339 Goodyear Bldg., Kansas City, Mo.

"Movie" Models Show How Machines Work

By ESTHER LINDNER
(Continued from page 859)

a separate exposure of the motion picture camera to tell the story of the action. What appears on the screen to be steady action is in reality a series of different pictures, which, when run off by the projection machine, give the effect of consecutive movement.

The parts of the machine are moved by hand into each consecutive position that is a part of the movement of the original model, and for each movement a picture is made. If one part is moved a fraction of an inch, and this movement has a corresponding effect upon the other parts, these too must be moved to the exact position they would occupy if the actual machine were in operation—and each time that this is done a picture is made. All this must be perfectly timed so that the final action, as it appears on the screen, may be smooth and convincing—without any appearance of jerkiness.

For this reason it is necessary that the fashioner of the fibre-board duplicate superintend its photography as well. He alone has studied the problem, knows it by heart, and its making was his particular job. It is almost impossible to write directions for the photographing of such a contrivance.

The advantages of such an idea are innumerable, and their media for application many and varied. For instance, it is impossible to set up a motion picture camera inside of an automobile to secure bits of the mechanism—and yet it may be just such bits that will be of the greatest value and interest to persons interested in motors. Such an experiment is being tried at the present time—a "mechnigraph" has been made of the vacuum gasoline-feed system used on modern motor cars—and this has been animated on the screen.

Incidentally the flashes of the vacuum feed system occupy 150 feet of film space. At the rate of sixteen exposures to a foot of film, it was necessary to photograph the "mechnigraph" 2,400 times. The making of the replica and preparing it for the camera occupied two weeks. The man who made it spent years perfecting himself in this work, the photography alone consumed two days, and the working of the "mechnigraph" occupies the screen for just two minutes!—*Photos courtesy Harry Levey Service Corporation.*

What to Invent

By JAY G. HOBSON

(Continued from page 885)

an intensive state, as it is drawn from the burning end thru the paper wrapper and into the mouth and lungs. If this be true, and no doubt it is, a new cigarette holder with a special cooling feature should prove invaluable to the millions of puffers inhaling regularly, as most inveterate users of the mystic weed choose to do.

As shown, the construction of this holder sends the smoke indirectly thru the holder into the mouth, instead of straight thru the holder as the present kind does.

By causing the smoke to travel further, it makes for cooler smoking, and the larger surface of the holder coming in contact with the nicotine in the smoke, should have a tendency to retain some of it, thereby keeping it from the mouth and lungs where the damage to the health is done.

As an advertising article for a special brand of cigarettes and cigars, large quantities could be sold.

(Copyright 1920 by the Author)

Here's the reason I wanted The Auto-Wheel Roadster

SEE how these sides work?—When I spread them out I have a hauling wagon. Just see how strong it is. Now suppose I want to coast, I push the sides towards the center. (They swing on pivots). Look at that roadster. Built just right. Wheels have real roller-bearings. No other wagon like it.

"And maybe you think it doesn't travel.—I'll challenge any boy on this street to a race."

The Perfect Christmas Gift

An Auto-Wheel wagon is a year-'round pal. You'll enjoy it throughout your boyhood. Besides the Auto-Wheel Convertible Roadster, we make the Auto-Wheel Coaster, the all-purpose wagon. Hand-some booklet describes all sizes and models.

Set your heart on an Auto-Wheel for Christmas. Show this ad to Dad. Send us names of 3 coaster dealers, telling which ones handle the Auto-Wheel. We'll send Free for 6 months The "Auto-Wheel Spokesman," our magazine telling about our BIG PRIZE CONTESTS and the Auto-Wheel Clubs. You may be able to win an Auto-Wheel. We'll also send the Auto-Wheel Coaster Dime-Savings Bank.

The Auto-Wheel Coaster Co., Inc.—
The Buffalo Steel Company
163 Schenck Street,
N. Tonawanda, N. Y.
In Canada: Preston, Ont.
Export Office: 365 W. 23rd
New York City



Auto-Wheel Spokesman FREE

Satin Solid Gold

Satin Solid Gold

Send Us Your Name and We'll Send You a Lachnite

DON'T send a penny. Just say: "Send me a Lachnite mounted in a solid gold ring on 10 days' free trial." We will mail it prepaid right to your home. When it comes merely deposit \$4.75 with the postman and wear the ring for 10 full days. **If you, or any of your friends can tell it from a diamond, send it back and we will return your deposit.** But if you decide to buy it—send us \$2.50 a month until \$18.75 has been paid.

Write Today Send your name now. Tell us which (men's). Be sure to send your finger size.

Harold Lachman Co., 204 So. Peoria St., Dept. 1259 Chicago

What a Dime Will bring You From the Nation's Capital

The little matter of 10 cts. will bring you the Pathfinder eight weeks on trial. The Pathfinder is an illustrated weekly, published at the Nation's center, for all the Nation; an independent home paper that prints all the news of the world, and tells the truth; now in its 28th year. This paper fills the bill without emptying the purse; it costs but \$1 a year. If you want to keep posted on what is going on in the world, at the least expense of time or money, this is your means. If you want a paper in your home which is sincere, reliable, entertaining, wholesome, the Pathfinder is yours. If you would appreciate a paper which puts everything clearly, strongly, briefly—here it is. Send 10c to show that you might like such a paper, and we will send the Pathfinder on probation eight weeks. The 10c does not repay us, but we are glad to invest in new friends. Address: **THE PATHFINDER, 265 Langdon Sta., Washington, D. C.**

Factory to Rider

Saves \$15 to \$25 on the model you select from 44 Styles, colors and sizes of Ranger bicycles. Delivered free on approval direct from the Makers for 30 Days Free Trial. We pay return charges if not satisfactory in every way.

12 Months to Pay Possession and use at once on our liberal new pay plan. Any boy or girl can save the small monthly payments.

Tires wheels, chains, parts and equipment at half usual prices.

BIG RANGER CATALOG FREE, with marvelous new prices, 30 day trial offer and terms.

Mead Cycle Company Dept. 1107 Chicago

Practical Chemical Experiments

By PROF. FLOYD L. DARROW

(Continued from page 871)

found in their behavior toward heat. Some are very easily melted and oxidize or undergo combustion with great readiness, while others are exceedingly resistant.

Mount a piece of platinum wire two and one-half inches long in the end of a short piece of glass tubing by fusing the two together in the flame of a Bunsen burner. Note the bright silver lustre of the wire and its flexibility. Now place the wire in the oxidizing portion of the Bunsen flame, i.e., the hot outer part just above the tip of the inner cone. As you will observe, the wire becomes white hot and seems to expand in size. Remove the wire, allow it to cool and note that it has the same bright lustre and flexibility that it had originally. The wire in no way seems to have been changed. All its properties are still intact. Such changes we call physical because the composition of the substance remains the same.

Next, by means of tongs, hold a 2-inch piece of magnesium ribbon in the flame of the burner. A very vigorous action accompanied by a flash of blinding light follows with great rapidity. When you have recovered your sight examine the white brittle residue that crumbles to a powder at the slightest touch. In no way does this new material resemble the original magnesium ribbon. The lustre, toughness and flexibility are all gone and it will not burn. Its properties have entirely changed and therefore we say that a chemical change has taken place and a new substance has formed. But since magnesium is an element it could have lost nothing in this change and, therefore, something must have been added to it. That something we shall see is oxygen.

Weight Change on Heating a Metal in the Air: That metals that undergo oxidation gain in weight when heated in the air can be very readily shown.

On one side of a horn-pan balance place a small porcelain crucible and fill it nearly full of granular tin, or "mossy" tin as it is called. Then just exactly counterpoise this with lead shot.

Arrange apparatus as shown in figure 1 placing the crucible of tin on the pipe-stem triangle. Using a small flame melt the tin and then gradually increase the heat. Continue the heating for about twenty minutes and stir the contents of the crucible frequently with an iron wire. You will observe a gray scum form on the surface of the molten tin and as you remove this with the iron wire the bright silver lustre immediately returns and as quickly vanishes. As you proceed the metallic tin disappears and a gray powder takes its place. When nearly all of the tin has been changed to this gray powder, turn off the burner and allow the crucible to cool without removing from the pipe-stem triangle. When it is cool enough so that you can handle it with perfect comfort again place the crucible and contents in the pan of the balance and note the weight change. Unless you have been very careless in your manipulation the balance will show a decided increase in weight.

What is true of tin is also true of other metals which oxidize when heated in the air. For many years in the early history of chemistry this simple fact was unknown and even for many years after its discovery the explanation of what had happened was a deep mystery. We now know that oxygen from the air unites with the metal.

Proof of the Oxidation of Copper: Cut a quantity of No. 24 copper wire into short

(Continued on page 920)



New Easy Way to Become An Artist

THIS wonderful new method makes it possible for *anyone* to learn Illustrating, Cartooning, or Commercial Art. Hundreds of our students are now making splendid incomes. And most of them never touched a drawing pencil before they studied with us.

The simplicity of this method will astound you. You will be amazed at your own rapid progress. You learn by mail—yet you receive *personal* instruction from one of America's foremost Commercial Artists—Will H. Chandler. Get into this fascinating game, NOW. You can easily qualify. A few minutes' study each day is all that is needed.

straight lines, then curves. Then you learn how to put them together. Now you begin making pictures. Shading, action, perspective, and all the rest follow in their right order, until you are making pictures that bring you from \$50 to \$500 or more! Many artists get as high as \$1,000 for a single drawing!

Crying Demand for Trained Artists

Newspapers, advertising agencies, magazines, business concerns — all are looking for men and women to handle their art work. There are hundreds of vacancies right this minute! A trained commercial artist can command almost any salary he wants. Cartoonists and designers are at a premium. Dozens of our students started work at a high salary. Many earn more than the cost of the course while they are learning! YOU—with a little spare time study in your own home—can easily and quickly get one of these big-paying artists' jobs.

Write for Interesting Free Book

Mail coupon now for this interesting free book "How to Become an Artist." Explains about this amazing method in detail. Tells of our students—and their wonderful progress — and how we can qualify you for a high-salaried artist's position. Also tells of our free artist's outfit and special low offer to a limited number of new students. Mail coupon NOW!

Washington School of Art
Room 1559, Marden Bldg., Washington, D. C.

FREE COUPON

WASHINGTON SCHOOL OF ART, Inc.,
Room 1559, Marden Bldg., Washington, D. C.

Please send me, without cost or obligation on my part, your free book, "How to Become an Artist."

Name

Address



CAPT. G. F. CAMPBELL

Learn Commercial Aviation Quickly At Home

Aviation is still in its infancy, but it is well past the trick stage. It is now a billion dollar industry needing thousands of trained men as pilots, mechanics, designers, salesmen, etc. You can enter this great new field of industry at a large salary after a few months of careful home study.

Course of Practical Aviation in National Aero Institute

will fit you for a big paying position in this giant industry. This nationally recognized course is directed by the famous British birdman, Capt. Geo. Frederick Campbell, R. F. C., who personally supervises the work of every student. It costs the U. S. Government \$25,000.00 to fit a man for flying. Most of this training is ground work. Our course completely covers ground work and enables you to master the fundamentals of aviation in a short time. National Aero Institute, Dept. 744-Z, 916 S. Michigan Ave., Chicago, Ill.

You want the BIG MONEY aviation offers. We show you how to get it. Fill in the coupon and let us tell you how. Gentlemen: Please send me without obligation, a copy of "The Science of Aviation," also particulars of Mail Course in the Principles of Aviation. You can enter this fascinating profession—Now.

Name

NATIONAL AERO INSTITUTE
916 S. Michigan Ave., 744Z, Chicago, Ill.

Address

Buy Your Xmas Gifts Now
Only a few cents a day

No Money Down

JUST send your name and address for our 128 page Christmas book of bargains in diamonds, watches and jewelry. Millions of dollars worth of jewelry from which to choose your Xmas gifts. Your selection sent on your simple request, *without a penny down.* If you don't think it is the biggest bargain you have ever seen, send it back at our expense. If you keep it you can pay at the rate of *only a few cents a day.*

8% Yearly Dividends
You are guaranteed an 8% yearly increase in value on all diamond exchanges. Also 5 per cent bonus privilege.

Write Today for Xmas Catalog
Send your name and address now. No obligation. Beautiful Xmas catalog comes free by return mail. Explains all about the Lyon Charge Account Plan. See this great collection of jewelry and more. *Send your name today to Dept. 38-J*

J. M. LYON & CO.
1 Maiden Lane, New York N.Y.

A Prophet of Science
By JOHN DE QUER
(Continued from page 845)

metal, providing the radium is not in too close a proximity. From this I have conceived the idea that the Alpha rays of radio-active substances if properly applied, may have a stimulating effect upon cell growth, while the Gamma rays may be directly associated with function. In these experiments I do not concern myself with function, but only with growth. Some years ago, Dr. Alexis Carrel started this line of experimentation, and produced some wonderful results, and I believe if the proper light or electric stimulation to which each cell responds can be found, that these experiments will lead to an industrial development which will make the ocean water available as food for the human race. If this can be done, then we may smile at the gloomy forebodings of Malthus for another thousand generations.

"You see life originated in the ocean. Here the cell had its birth. It transformed sea water into its substance. The analysis of our bodies and that of sea water are very similar; they differ only in proportion. The cell is an aquatic creature; it has never left its original habitat. Our bodies are a cooperative commonwealth of cell colonies floating in a saline fluid. The small animals of our California deserts, which do not see water for years at a time, manufacture that fluid by chemical or electrical reactions going on in their intestinal tract from the starches in their food. The periods of gestation and other vital functions simulate the phenomena of the tides. Doubtless this is because the cell evolved in Paleozoic times under tidal conditions, and living things today, being nothing more than highly complex associations of cell groups, which differ from each other only because the media in which they develop differs in chemical composition, still responds to the conditions of its primitive home."

He removed the cap from the bottle, and took out the lungs which he now subjected to the galvanometer test demonstrating that the needle moved in the same way as in the test on the living dog. "After this cat has been dead two weeks its lungs still live," said he. At this point the dog on the table began to stir. He was coming out from under the anesthetic. "Poor pup," remarked the experimenter, "I have cut him up too much to save him. Dog Heaven is the place for him." So saying he took a sharp bistoury from his instrument case and with a deft movement of his hand, severed the spinal chord from the medulla. Respiration ceased immediately.

With his stethoscope he listened to the heart of the creature until that organ had ceased to beat. It took some time. "When the heart and lungs of an animal have ceased to function they are generally supposed to be dead," he explained. "But I will show you that the individual cells of this dog are not yet affected by its organic demise." With a few strokes of his knife he excised several of the creatures muscles. These he laid on a plate of glass and subjected them to the galvanometer test, with similar results to those obtained when they were part of the living dog.

"Now I will return the cat's lungs to their artificial nest, and make similar nests for 'Sports' running gears," he purred as if to himself, "and two weeks from now I can assure you, they will be as alive and fresh as ever, no matter what becomes of the rest of the dog's anatomy."

"Rudolph Virchow has said that 'disease is resident in the cell.' He stated a partial

Send No Money
GENUINE \$12 IMPORTED VELOUR HAT



FULL OF JAZZ AND PEP
BECOMING TO YOUNG AND OLD

Write quick for this amazing bargain. Only limited lot. Wonderful quality, imported velvet, record-breaking cut price.

Just send address and size for this wonderful imported genuine black velvet hat. Beautiful fedora style, flexible brim. Can be turned up or down. Made of the finest quality, very silky, imported black velvet. Fine wide grosgrain black silk ribbon band. Genuine leather, non-soluble sweat band. A hat you can wear, season after season, for years. Don't Send a Penny - Pay only \$6.89 C. O. D. We pay delivery charges. We Guarantee to refund your money immediately, if you can match it for less than \$12.00. Write Today before this astounding offer is withdrawn. Be sure to give size.

BERNARD-HEWITT & COMPANY
Dept. H-3912, 900 W. Van Buren St., Chicago, Ill.

Play the Hawaiian Guitar
Just Like the Hawaiians!

Our method of teaching is so simple, plain and easy that you begin on a piece with your first lesson. In half an hour you can play it! We have reduced the necessary motions you learn to only four—and you acquire these in a few minutes. Then it is only a matter of practice to acquire the weird, fascinating tremolos, staccatos, slurs, and other effects that make this instrument so delightful.

The Hawaiian Guitar plays any kind of music, both the melody and the accompaniment. Your tuition fee includes a beautiful Hawaiian Guitar, all the necessary picks and steel bar and 52 complete lessons and pieces of music. An ideal Christmas gift.



Send Coupon NOW
Get Full Particulars FREE

First Hawaiian Conservatory of Music, Inc.
233 Broadway NEW YORK

I am interested in the HAWAIIAN GUITAR. Please send complete information, special price offer, etc., etc.

NAME

ADDRESS

TOWN

STATE

Please write name and address clearly. E. E.

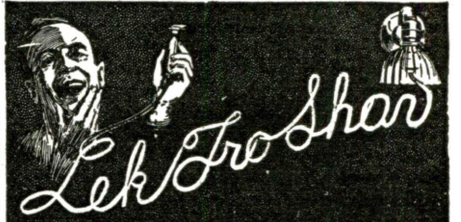

The Electric Safety Razor makes shaving a pleasure. Blade vibrating 7,200 times a minute cuts the beard smoothly and without slightest pull or irritation—feels like a gentle massage. Can be used with or without electric current.

All users of the Lek-Tro Shav speak well of it

A barber says—"Have shaved for years and have never used any shaving device near its equal."
A home user says—"The most pleasing shave I've ever had in my life. Shaves my face closer than I used to shave, but there is no after irritation or ill effects as I usually get from another razor."
No. 1 Made for use from Light Socket.
No. 2 Made for use from Dry Battery.
Write for illustrated circular describing Lek-Tro-Shav Safety Razor fully.

VIBRATING ELECTRIC RAZOR CO.
Dept. 122, Council Bluffs, Iowa

NEW MOTOR BARGAIN

GENERAL ELECTRIC

1 HP Motor 110 V. A. C. 60 cycle single phase. 1750 Speed. Complete with Cord, Plug and Grooved Pulley.

Will operate \$23.50 Washing Machines, Sewing Machines, Small Lathes, Grinders, Bottle Washers, Etc.

Satisfaction guaranteed or money refunded.

Illustrated catalog of motors and supplies FREE

HYRE ELECTRIC CO.
631 South Dearborn Street Chicago, Ill.

Learn the Sign-Show Card Business

Big field—no limited possibilities—increasing demand for men with creative ideas. Our course develops ability and originality. Work intensely interesting.

EARN \$25. TO \$75. WEEKLY

You can do it if ambitious. Successful graduates everywhere. Our course covers every phase of work completely and thoroughly. Our graduates command big salaries. Write for catalog, samples, guarantee and Free Outfit Offer.

DETROIT SCHOOL OF LETTERING, 632 B.S.L. Bldg., Detroit, Mich.

SECRET SERVICE
Operatives, Detectives and Investigators are in big demand; earn big salaries; fascinating work. Be independent. We show you how by home study. Write American School of Criminology, Dept. B. Detroit, Mich.

MAKE BIG PROFITS
from HB Battery Charging

BIGGER PROFITS THIS WINTER

With winter here and cars being stored, HB battery charging can pay you \$150 to \$250 extra profit every month. Someone gets the business of charging those batteries—why not you? Start now—get a sturdy, dependable HB Charger with ample capacity to handle this profitable business.

THIS HB 16-BATTERY CHARGER Recharges 1 to 16 6-volt batteries or equivalent at once. Uses 2 or 3 phase city current—cheapest and best. Current cost 4c to 12c each—owner pays 75c to \$2.00. Quick, clean, permanent profits easily made.

Small Payment Puts This Money-Maker in Your Garage or Shop. Balance on easy monthly terms. Ten days' trial under HB Absolute Money-Back Guarantee. Write

HOBART BROTHERS COMPANY
Box 1210 E. TRBY, OHIO
Successful Manufacturers Since 1898

Be an Artist

Comics, Cartoons, Commercial, Newspaper and Magazine Illustrations, Postal Oregon Portraits and Fashions. By Mail or Local Classes. Write for Terms and List of successful students.

Associated Art Studios, 111 Flatiron Bldg. New York

truth. One phase of life manifests itself thru the cells, and disease means that the cell's transforming power is below par. Highly organized beings manifest two forms of energy. Let us call them the vegetative and the functional. The vegetative is energy manifesting itself as growth, and the functional is that energy used in the struggle for existence. Growth is due to a multiplication of the cell units, while functional energy is due to the circulating of the blood cells. These little workers add to their individual transforming power that of their mass movement. It is due to the cutting of the lines of force in the earth's field by the circulating blood that warm blooded animals are capable of such prolonged and intense exertion. The earth's magnetic field is the source of their dynamic energy.

"But what I especially want to call your attention to is the fact that the death of the individual and the death of its component cells are two separate and distinct phenomena. And in this fact lies the solution of some of the big problems which confront the human race today, and the solution of which will become imperative as the years roll on. But I am getting ahead of what I wish to say right here.

"As I have said animal life is due to the activity of harmoniously cooperating cell groups called organs, growing and functioning in a chain of media, each of slightly different chemical composition, according to the requirements of the cell forms they supply. It is my idea that the waste of one tissue alters the blood in such a way that it becomes a proper culture medium for the next, and so on until all organs have been supplied, when the unusable waste is thrown out of the system by the organs of elimination. If this is true then health depends solely upon the perfection by which one set of tissues prepares the nutrition for the next. Tissues grow or suffer in direct proportion to the chemical sufficiency or insufficiency of the fluid on which they are fed. Of course there are other factors but these need not worry us now. What I am interested in is in the growth of tissue for human consumption apart from sentient organisms.

"Animals, and not their organs differ from such plants as the geranium, willow, or cotton-wood tree. These you may cut to pieces and each piece if suitably planted will make a complete plant or tree. They are comparatively simple organisms growing in a single medium, while an animal is a complex organism growing in a chain of media. Thus what is true of the geranium cutting is also true for our various organs, the difference being that while the geranium is planted in the soil, the organs are planted in different fluids, automatically supplied by the cooperative action, of their vegetative and functional activity.

"If I can succeed in demonstrating these facts beyond the peradventure of a doubt, they will prove to be of immense importance to science, especially to therapeutics. As yet we have no science of medicine. Medication is to a great extent guess-work and experimentation. Doctors still wince when some one quotes Voltaire's sarcasm, that Doctors put drugs of which they know little, into bodies of which they know less, for diseases of which they know nothing. How can we know very much concerning the processes of disease which is the approach of death as long as we do not understand the true nature of life, the perfection of which spells health? We have no right to hide behind a metaphysical bugbear which would make of life an impenetrable mystery. It is no more an impenetrable mystery than was the inland of Africa or the North Pole. I firmly believe that every phenomenon in the universe can be traced to a single cause, and that to this rule life is not exception; if it is, then the word 'universe' is a misnomer."

Starrett Books - Vol. I and II

75¢

If You are an Apprentice—

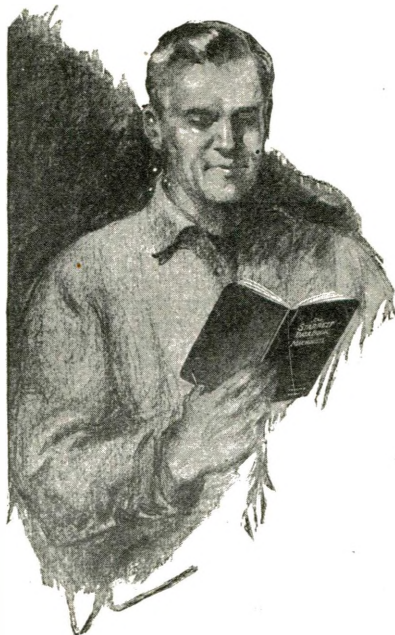

You take your problems to the STARRETT BOOK FOR MACHINISTS' APPRENTICES. It helps you to solve them.

But, if you've completed your time and are a MACHINIST—the old problems no longer puzzle you, but there are new ones that DO.

They're answered in Volume II of this series, THE STARRETT DATA BOOK FOR MACHINISTS.

Four editors, each an expert in his field, have selected its tables and formulas. Gear-cutting feeds, power transmissions data, strength of materials, etc.—you'll find these and many more in its 180 pages.

Bound in red Athol leather. Size 4½ x 7. Price 75c. Get either of them at your dealers, or order directly from us. Catalog No. 22 "LE" is a handy reference book. Sent free upon request.

THE L. S. STARRETT CO.
The World's Greatest Toolmakers
Mfrs. of Hack Saws Unexcelled
ATHOL, MASS.

Use Starrett Tools



Does ALL Your Gasoline Explode?

OR does part of it just clog up the cylinders in the form of carbon—through an inefficient spark?

Put an Alsop-All-Spark on your car and your old, cracked, oil-soaked plugs will now give a hot, fat spark that explodes every particle of the gas. You will find unexpected power in your car and your carbon troubles will be gone forever. Government tests prove that an All-Spark actually will eliminate carbon—besides getting 100% power out of your engine.

You can try an All-Spark with no risk. It is fully guaranteed and your money will be refunded in full if you are not thoroughly satisfied. Incidentally, the saving in gasoline and new spark plugs alone will soon pay the cost of an All-Spark.

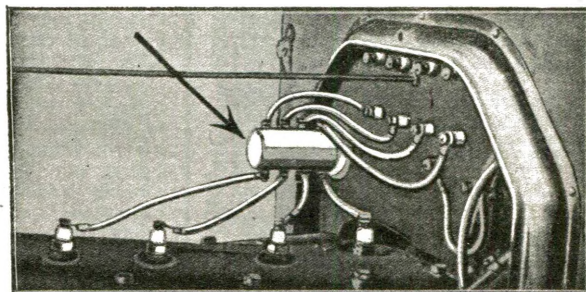
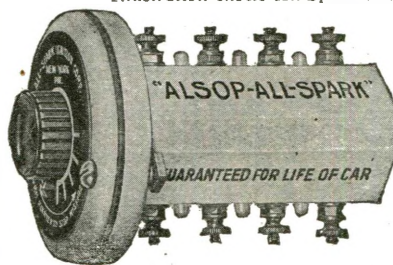

Illustration shows All-Spark attached to a Ford



ALL-SPARK IGNITION COMPANY
13-X Water Street,
New York, N. Y.

Gentlemen:
 Enclosed please find remittance for \$7.50 for which please send me one Alsop-All-Spark Intensifier for a four cylinder engine together with full instructions for installing it in ten minutes.

Name.....
Address.....
City.....
State.....

ALL-SPARK IGNITION COMPANY, Inc.
13-X Water Street, New York, N. Y.

**WHAT WOULD IT MEAN
—TO YOU—TO HAVE
MUSCLES LIKE THESE?**

It would mean tremendous strength, putting you in a class above your fellows. It would mean that you could out-do them in feats of strength and be a leader of men. It would mean a strong personality because of your commanding appearance, thereby assuring you of success in both the business and social world. It would mean added power, unlimited energy, vitality and perfect health; removing all fears of indigestion and disorders which undermine the average man and make him old long before his time.

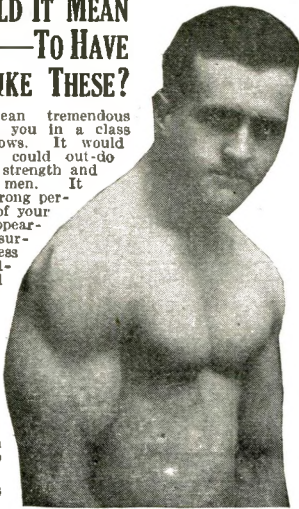

EARLE LIEDERMAN
The Acme of Physical Perfection

**All These Things
Are Yours**

I absolutely guarantee to do all this and more for you. I have found the short cut to physical perfection and applied it on my own body, proving its results. I have personally trained many of the world's strongest men by this same method. Why waste your time and money with old-time worthless methods? If you are desirous of being a real robust man, follow the path of those who have already made a success. Come now, get busy, for every day counts.

Send for My New Book, "Muscular Development"

It tells the secret. Handsomely illustrated with 25 full-page photographs of myself and some of the world's best athletes whom I have trained. Also contains full particulars of my splendid offer to you. The valuable book and special offer will be sent on receipt of only 10c, stamps or coin, to cover cost of wrapping and mailing.

Don't miss this opportunity. Sit right down now and fill in the coupon. The sooner you get started on the road to health the easier it will be to reach perfect manhood. Don't drag along one day longer—mail the coupon to-day.

EARLE E. LIEDERMAN, Dept. 212, 309 Broadway, N. Y.

EARLE E. LIEDERMAN, Dept. 212, 309 Broadway, N. Y. City

Dear Sir—I enclose herewith 10c for which you are to send me, without any obligation on my part whatever, a copy of your latest book, "Muscular Development."

Name
Address
City State

He paused in his conversation—returned the carcass of the cat to the ice box—and called his negro servant to dispose of the remnant of the dog, after which he busied himself with the muscles he had excised and which lay still quivering on the plate of glass.

Taking one of the muscles, he attached it to one of three silver pipettes which were fixed in a large bottle stopper; from it he suspended the muscle in a bottle of similar dimensions to the one in which he kept the lungs of the cat. The pipette, from which the muscle was suspended, he attached to an oxygen tank by means of a soft rubber tube, while another was past thru a small hole in the bottom of the bottle in such a way that it protruded far enough so that its end would fall well below the hole provided for it in the shelf upon which the bottle was to rest. To the end of this pipette which fell below the shelf, he fastened a little safety valve, which he regulated so that it would keep the required gas pressure within the bottle. This tube was run up into the bottle to a point just above the fluid level, where, as the Doctor explained it could take up the carbon dioxide created by the metabolism of the muscle and expel it from the confines of the tissue. The other two pipettes in the stopper, he connected, one with the media tank, as he called it, and the other to an adjoining bottle in which was suspended a specimen of another tissue. There was some kind of pumping device which moved the media from one bottle into another at a definite rate of circulation. "The muscle cells take nourishment from the medium in which they are placed, they also excrete waste into it; hence we must provide for the circulation of the fluid. Fluid which has once been used by a tissue must not return to it again until it has been purified of all the excreta produced by the metabolism of that tissue. This, I have found, is best accomplished by the growth of other tissues. The only thing that makes different cell types in one organism possible is the fact that the morphological structure of the cell varies according to the media in which it finds itself. Thus the excreta of one set of tissues becomes the culture media for the next, and if we are to produce them artificially, with any degree of success, we must endeavor to imitate the requirements of nature as nearly as is humanly possible," he explained enthusiastically.

"But what is it you expect to gain from all this work? Where is the money in it?" I asked genuinely puzzled. The last question I felt sure would bring from him an excited flood of oratory, but in this I was disappointed. Nothing excited this dynamo except obscure phenomena; they, and they alone, set him to work.

"In the first place," said he, ignoring my reference to our modern god. "I am trying to discover what life is, and what are all the conditions on which it depends for its fullest and freest manifestations. The lack of such knowledge, fills our text-books on physiology with statements expressing doubt and uncertainty. Much of what the laity takes for truth is mere hypothesis. There are whole series of secretions, the nature of which we do not understand, and which, we therefore are as likely to hinder as to help with our medication.

"Society has intrusted us as doctors with the care of that highly complex mechanism we call the *human body*, the functional motive power of which we do not understand, not because that motive power is unknowable, but because science has just penetrated into that world of forces from which the material universe arises. We have always regarded life as a phenomenon of matter, we may have to come to the conclusion that matter is a phenomenon of life. Radio-activity and electricity are the beacon lights on the shores of the world of matter; they point the way into a sub-material universe, and it is in this universe that we



GLORIA SWANSON
Cecil B. DeMille Artcraft Player

WALLACE REID
Paramount Star

Hermo "Hair-Lustr"
(Keeps the Hair Dressed)

For Men, Women and Children

The hair will stay dressed after Hermo "HAIR-LUSTR" has been applied. No more messy, untidy looking hair. Adds a charming sheen and luster, insuring the life and beauty of the hair. Dress it in any of the prevailing styles, and it will stay that way. Gives the hair that soft, glossy, well groomed appearance so becoming to the stars of the stage and screen. Guaranteed harmless, greaseless and stainless.

50c and \$1 at Your Dealer
\$1 size 3 times quantity of 50c size. If your dealer can't supply you we will send it prepaid upon receipt of price. Remember your money back if dissatisfied.

HERMO CO., 542 E. 63rd St., Dept. 1012, CHICAGO

**A COMPLETE COURSE IN
COMIC DRAWING**
CARTOONING CARICATURE & LETTERING
FOR ONLY \$5

With this complete Course you can quickly learn to draw the COMICS, CARTOONS, CARICATURES, LETTERING, THE CHUCK-THINKER EXERCISES, etc. Over 300 illustrations. With our Modified Skeleton System you can easily learn to make original drawings. This course gives you all the "inside dope" and "short cuts." It explains the entire subject from A to Z. The Materials, General Instructions, Pen Lines, Enlarging, Reducing and Reversing Pictures, Lettering, How to draw the Head, Eyes, Ears, Nose, Mouth, Hair, Hats, Caps, etc., Anatomy, The Skeleton, Modified Figures, The Body, Feet, Clothing, Wrinkles, The Hand in 80 different positions, The Feet, Shoes, Boots, Etc., Expression 18 different plates, Caricaturing, Portraits, Perspective, Fore-shortening, Shading, Shadows, Composition, The Right and Wrong Way, Timely Remarks, How to Sign Your Name, Etc. Complete course printed on drawing paper and neatly bound in book form. Write your name plainly. Postpaid \$5.

Ernie's School of Comic Art, Dept. Q, Elyria, Ohio

Oh Boy! Build This Car.

This nifty little car driven by gasoline motor, can be built by any boy. Parts are furnished by us and are very cheap. Send 30c for building plans and price list of parts showing how to build this lad's car.

SYMPHER MFG. CO., 156 Sypher Bldg., Toledo, Ohio

MATHEMATICS MADE EASY

The Arcascope—the Combination Triangle with a Brain—will multiply, divide, figure percentage and proportion, solve all problems in trigonometry and geometry, draw symmetrical figures, plot arcs, etc. Superior to any slide rule. Simple to operate. Also includes a TRANSPARENT TRIANGLE, PROTRACTOR and THREE RULES. Used at Columbia University, West Point, U. S. Aeronautic Schools, etc. Only One Dollar. Postpaid. Order today before you forget.

Dept. J, L. J. LEISHMAN CO., Ogdenville, Utah

WHY DON'T YOU WRITE THE WORDS FOR A SONG

WE'LL HELP YOU ALONG

By composing the music free and publishing same. Send poems to-day.

D. N. LENOX CO., 271 W. 125th St., N. Y.

READ LOCOMA

—an interesting, instructive MAGAZINE, on personal subjects, such as Love, Marriage, Divorce, Eugenics, Birth Control, Sex Hygiene, etc. For Men and Women only. 15 cents a copy, \$1.50 a year, 8 months' special trial 50c.

100 E.E. & M. Bldg., Farmington, Mich.

You can be quickly cured, if you STAMMER

Send 10 cents coin or stamps for 70-page book on Stammering and Stuttering, "Its Cause and Cure." It tells how I cured myself after stammering for 20 years.

Benjamin M. Bogue, 773 Bogue Bldg., Indianapolis

1/2 SAVED
GET OUR
BIG BOOK

BURN LESS COAL

With an improved, all-cast pipeless furnace you can cut your coal bill in two. This efficient, basement installed heating plant heats and ventilates the entire home. It burns any grade of coal more economically than a stove. It needs no expensive piping or other equipment. Anyone can install it in a day. They are described at our wholesale prices in our Handy Man Book. Send for it.

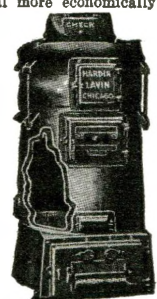

Do Your Own Plumbing and Heating by the Cut-to-Fit Method.

By our new plan anyone can install a complete plumbing or heating plant in his own home. Send us a rough sketch with measurements. Our Engineers will draw your plans, furnish information and see that the supplies you order come CUT-TO-FIT your needs. No waste of time, labor or unused material. Only a few simple tools necessary. Send for

The Handy Man Book

It will show you how. It will tell you just what to order and what it will cost at our wholesale prices. It contains plans and useful information for every builder, property owner or contractor. It will convince you. It will increase the value of your property 50%. You can do the work yourself.

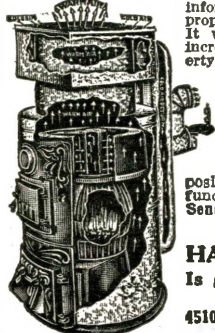

We have spared no effort or expense in the preparation of this valuable book. To keep from sending it broadcast to uninterested persons we request a temporary deposit of 25c which will be refunded with your first order. Send for it Today.

The Service of HARDIN-LAVIN CO.
Is guaranteed by 40 years' business at
4510-20R Cottage Grove Avenue CHICAGO

must seek for the ultimate cause of life's processes.

"But this field is comparatively new while medicine is old; it moves but slowly on these heretofore untrodden paths. Doctors are unaccustomed to think of life in terms of electro-magnetic lore; but they will have to come to it, if medicine is ever to become what it ought to be, a pure science. As it is now we are treating a highly complex generator as if it were an internal combustion engine, with the result that we not infrequently short-circuit the machine."

He walked over to the table which stood in the center of his laboratory and picked up several fairly large horseshoe magnets. These he clamped together with small brass clamps, fastened them to an upright in such a way that their open ends fitted over a copper disc, which he now set in motion with a fan motor. By means of the bare ends of an insulated wire he drew off from the swiftly rotating device a shower of sparks, explaining as he did so that it was the copper cutting the lines of magnetic force that produced the electricity. "Hemaglobin contains iron. Iron is affected by magnetism, from which I conclude that its circulation thru the vascular system must give rise to electrical phenomena, which I believe lie at the basis of the functional activities we behold in living organism," he explained.

"But cannot these be explained upon the well established laws of chemistry." I asked. "Is it really necessary to consider the body as a dynamo instead of an internal combustion engine in order to fathom the mysteries of life?"

"It would be all good and well to stay within the bounds of 'the established laws of chemistry' if we really knew them in the strict sense of the word," he replied quietly. "But you must not forget that much of what we considered 'well established' twenty years ago is today being shaken to its very foundation. The electronic theory of matter is going beyond the atomic theory. The search for the primal cause has past out of the hands of the chemist and into those of the physicist. Radio-activity has revealed to us a new continent in science which it is for us to explore. This continent stretches from the atom to the 'Prima Causa,' and in it lie the secrets of *electricity, magnetism, gravitation, repulsion, and life itself.* These are all pre-atomic forms of the one thing which composes this universe. As I have said, they are pre-atomic forms of energy. How then are you going to seek for them in what you are pleased to call 'the well established laws of chemistry.' These laws deal with the action of atoms on one another, while these pre-atomic forces give rise to the atoms themselves. Gravitation is only manifest to us thru the weight of material things. Electricity we know chiefly by its result. Heat is only manifest thru material media, and life is only recognized in animal or vegetable form."

He leaned against the table and ran his fingers thru his wavy blonde hair, while a whimsical smile played about his whip-like mouth. "Some day I will show the world, not only what life is, and upon what it depends, but also the rôle it plays in the formation of the so-called inorganic universe. It may sound terribly heterodox but I have a notion that not a few elements undergo transmutation in living organisms. Elements, like the organisms they compose, have their birth death and transformation period."

"Surely you do not hold this view seriously?" I asked. And then, in order to draw him out on this point, I added that I was under the impression that science had demonstrated beyond the peradventure of a doubt, that nothing could be found in organic beings that did not enter into them in molecular or atomic form from their environment. I was willing to concede that

Try These "Pay Raisers" At our Expense - Order On 5 Day Trial

DRAKE'S PRACTICAL BOOKS FOR HOME STUDY

These books will perfect you in your trade—pave the way to the big position. We will send any book postpaid. If not entirely satisfied return the book and your money will be refunded in full.

Modern Electrical Construction
By Horstmann & Tousley. A perfect guide for the beginner. Valuable to the journeyman. Of special value to the inspector. Explains in detail how good electrical work is installed. 440 pages. 263 illustrations.
Leatherette Binding **\$1.75**

Easy Electrical Experiments and How to Make Them
By L. P. Dickinson. Equally valuable to the amateur or the practical electrician. Gives in plain language all the information you want about every kind of electrical apparatus. 220 pages, 110 illustrations. Cloth Binding.....**\$1.25**

Telegraphy Self Taught
By Theodore A. Edison. Clearly and concisely written. Tells how to easily train the ear to receive messages by the audible alphabet system. 170 pages. Fully illustrated. Cloth Binding.....**\$1.25**

Electricians' Operating and Testing Manual
By Horstmann & Tousley. A practical handbook for working electricians. Covers installation, operation, testing, maintenance and repairs of all electrical apparatus. 361 pages. Illustrated.
Leatherette Binding **\$1.75**

Operators' Wireless Telegraph and Telephone Handbook
By V. H. Llaughter. Describes in detail the construction of a wireless set, the winding of spark coils and the tuning of a wireless station. Written in non-technical language. 210 Pages. Cloth Binding.....**\$1.25**

Order Direct Today On Our Money-Back Plan
Over a hundred pay-raising books for every trade are listed in our big illustrated catalog. Write for free copy.
FREDERICK J. DRAKE & COMPANY, 1009 Michigan Ave., Chicago, Ill.
Drake Books are for sale at all book-stores.

Earn Big Money

E.J. SWEENEY
PRESIDENT

Pack your grip today and come to the Sweeney School of Auto-Tractor & Aviation Mechanics. Strike out for the big money and a world wide opportunity.

Expert Mechanics Wanted The machine expert is the boss of creation today, whether on the farm or in the city. If you are mechanically inclined learn to make and repair autos, tractors, trucks, gas engines, auto tires, etc., in **Eight Weeks** by **The Sweeney System** OF PRACTICAL EXPERIENCE

Learn as 85,000 other men have learned—by tools, not books. Learn power farming on my big Tractor farm—18 tractors. Learn to make a \$30 tire from 45c worth of junk. Learn to fix any piece of machinery. You can't get this System anywhere else. Thousands of opportunities for experts trained in this Million Dollar School—the greatest in the world.

FREE Send today for my 72-page catalog, or simply say when you're coming and I will have classes arranged and your rooms ready. I guarantee railroad fare round trip if you find a single misrepresentation.
EMORY J. SWEENEY,
President

LEARN A TRADE
Sweeney
SCHOOL OF AUTO-TRACTOR-AVIATION
844 SWEENEY BLDG. KANSAS CITY, MO.

John Smith

\$1 For This Guaranteed Fountain Pen

An extraordinary offer to introduce the Big Bash Diamond catalog. Diamonds listed as low as \$97.50 per carat. Pen is a safety lever self-filler simplest and most practical fountain pen ever made. Barrel and cap of first quality Pararubber. Your name in gold free. Pen is 14K solid gold iridium tipped and hand tempered. Full size—6 1/2-in. long. Free repairs for two years guaranteed. Send \$1.00 for pen today. Money returned if not satisfied, or ask for free diamond book. Free examination on everything. **L. BASCH & CO., Dept. A3660, State & Quincy Sts., Chicago.**



General Manager at 28

How Mr. Rohrschneider Won Success as an Electrical Expert

GENERAL MANAGER of his company at 28 years of age! His own boss—owns his home—married and happy and prosperous—that's the remarkable success achieved by Wallace H. Rohrschneider, now General Manager, Secretary and Treasurer of the Hustiford Light, Power and Manufacturing Company of Hustiford, Wis.

Mr. Rohrschneider got his start toward his quick and brilliant success at School of Engineering of Milwaukee. There he received the practical, intensive and specialized training that enabled him to make good in a big way.

Why Don't You Get Into This Big Pay Field?

The same kind of training that put Mr. Rohrschneider into the ranks of the highly-paid Electrical Specialists will qualify you for brilliant success in this fascinating field of unlimited opportunities. Come to America's Greatest Institution of Electrical Education. Learn by actual practice in our big laboratories with their magnificent equipment, including motors, dynamos, switchboards, ignition and lighting systems, etc. Over 50 recognized experts give you personal instruction every step of the way.

Earn Your Way Through This Great College

You can earn money to help defray your expenses while you are learning. Our wonderful cooperative plan brings an Electrical Career within the reach of every ambitious man. Our Free Employment Department secures positions for those students who wish to earn part or all of their expenses. In addition, the Department will help you get a good position in the Electrical Industry when your training is completed.

BIG BOOK FREE Mail the coupon today for our big new illustrated catalog. Check the course that interests you most and we will send you special information. Read about the wonderful method of training of this great Electrical School that trains men for practical and quick success. See how easy it is for you to get the training that will enable you to step to a splendid position and a handsome income. Mail the coupon right NOW. No cost or obligation.

SCHOOL of ENGINEERING of Milwaukee

Dept. S-13, 373 Broadway Milwaukee, Wisconsin
Mail Coupon Now

SCHOOL OF ENGINEERING OF MILWAUKEE Dept. S-13, 373 Broadway, Milwaukee, Wisconsin

Please send me, without any cost or obligation, full particulars of the electrical course I have checked and your big Free Book telling about your institution and how it will fit me for a big position in the electrical field. Also tell me about your Earn While You Learn plan.

(Check courses interested in.)

... School of Practical Electricity—1 year course. Complete general course, covering entire electrical field.

... Institute of Electrotechnics—12 to 36 months' course. Practical electrical training combined with thorough Academic education.

... School of Electrical and Mechanical Drafting—6 months' to 1 year course. A general drafting education. Prepares for good position as skilled draftsman.

... School of Electrical Engineering—3 years' course. Regular collegiate work granting B.S. Degree. 14 High School units or diploma from our Institute of Electrotechnics required for entrance.

... School of Automotive Electrotechnics—3 to 6 months. Covers all systems of starting, lighting, ignition and storage batteries for automobiles, tractors, air-craft, etc. Intensive practical course.

... Armature Winding and Motor Generator Repair Course—3 to 6 months' course. Brief, but intensely practical, leading to well-paying positions.

Name
Street
City State.....
Age Education.....

molecular rearrangement took place in both animal and plant structures, but that there was such a thing as *atomic transmutation consequent upon vital activity* seemed to me a dangerous heresy.

But my objections only brought a smile to the face of the earnest experimenter as he pursued his activity among the culture jars. Turning a stop cock here, and reading a dial there, testing the acidity of this fluid and the specific gravity of that, marking the results of his findings in his ever-ready note-book while he talked, as if he were thinking aloud,—he did not present any counter arguments to what I had said but just explained his views, and demonstrated his principles in a way that marked him as a unique man among my scientific acquaintances. He just talked, and his expressions are always interesting and unique. It is an education to listen to him. His philosophical deductions may not always be orthodox, and he may misinterpret the meaning of his experiments. I do not know. I only know that all those who have the privilege of his friendship will agree that his achievements are remarkable.

Dr. Pringle is always at work. He seldom busies his mind with abstract propositions. "Demonstration beats argument," is one of his favorite sayings. Whenever he makes a statement, he wants to work it out before your eyes. To be a teacher through deeds seems to be the motive power of his life.

Thus while working he replied to my challenge of his scientific orthodoxy. He contended that science was always right but that scientists were frequently wrong. Said he: "Scientists fish for truth, with a generous share of fisherman's luck. When they do make a catch it is a big one, but they are of necessity few and far between. And the species of the specimens are not always certain. The trouble with us is, that we are inclined to stick to one side of the boat; and if some one suggests that we try the other side we are apt to call him irregular. That is why we persist in looking for the nature of life in atomic reactions; we have the habit. The idea that life may be itself an atom-forming power comes from the other side of the boat, and is therefore taboo. The idea that there are eighty distinct substances in the universe, is not only ridiculous but dead; it only survives as a scientific superstition, marring in no small degree our progress on the path of knowledge.

"Sir William Ramsay and others, have witnessed the birth of helium from the death of radium, as well as its intermediate phenomena. Is it then too much to conceive, that what happens in Sir William's laboratory, may, I do not say does, happen in the infinitely more complex laboratory of the animal or vegetable body."

By this time he had finished checking up on his culture jars and he continued his conversation. "As sometimes happens in mathematics, when we invert the problem the truth drops out, so it is in biology and for that matter in all sciences. Many things remain unexplained because we approach them from the wrong side; that is why I have inverted the problem of life; and while I do not say that I will solve the mystery, I do say that I have approached nearer to the solution than ever did my preceptors.

"Some day I will take you out and show you the laboratory on my ranch by the sea. I am doing some interesting work on both animals and plants. Modern science has proven that there was more than a grain of truth in the idea of the ancient alchemists, that matter could be raised to higher values. In the case of radium at least we have discovered that elements can be stepped down to lower values and by parity of reasoning, what can be stepped down can be stepped up. If atoms are condensations of electrons it may be a good guess that living organisms play a part in that conden-

"The Baby" Double Action Revolver

A Handmade and Most Effective Weapon. Measures but 4 1/2 inches Long. Takes Regular .22 Calibre Cartridges. **\$6.50**

The new Baby Double Action Hammerless Revolver has been produced to meet the increasing demand for a revolver that would combine the essential features of *Efficiency and Practicality*. It is small in size, yet it is just as effective and as durable as the most expensive revolver you can buy. Everyone should have a revolver and should know how to use it, and no one can feel safer or better equipped than with it. A great feature is its safety action that guards against accidental discharges, making it most safe for young men and ladies. The illustration gives an idea of its appearance, but it must be seen and used to be thoroughly appreciated. The ammunition used is the standard .22-calibre cartridge obtainable anywhere. The operation of the charging mechanism is extremely rapid and absolutely reliable; six well aimed shots can be fired in as many seconds. The revolver is very well constructed, with flame nickel plated finish, barrel of blued steel, and it weighs only 4 1/2 ounces. The price of the Baby Revolver is only **\$6.50** sent by mail, p.p.d. in our address.



Cut Your Own Hair

Only 50c
Extra Blade, 50c

SAFETY HAIR CUTTER Can cut your own hair with this marvelous invention. Cuts the hair any desired length, short or long. Does the job as nicely before your own mirror. You can cut the children's hair at home in a jiffy. Use as an ordinary razor to shave the face and absolutely reliable. Sharpened like any razor. Saves its cost first time used. **3 for 15 cents.**

INVISIBLE INK VANISHING INK

The most confidential message ever written. For the writing **MARKER NO. 255**, which can be used for any purpose unless you know the secret. Invisible for many reasons. Keep your post-office communications safe. For the writing **MARKER NO. 255**, which can be used for any purpose unless you know the secret. Invisible for many reasons. Keep your post-office communications safe.

MAGIC FLUTE

Wonderfully Sweet Toned and Musical. The Magic Flute, or Vocal Harmonium, is a unique and novel musical instrument that is played with one's mouth. It is small in size and is just a little larger than a pocket watch when once assembled. It is so simple to use that any one can play it. It is a wonderful accompaniment to a piano or any other musical instrument. The effect is as if you were playing a whole orchestra. **25c per pair.**

LUMINOUS PAINT

Make Your Watches, Clocks, Etc., Visible by Night. The very latest discovery in the world of luminous paint, which, when applied to the surface of any article, emits rays of white light, rendering it perfectly visible in the dark. The **DARKER THE NIGHT, THE MORE BRILLIANT IT SHINES.** Quite simple to use. A little applied to the dial of your watch or clock will enable you to tell the time by night. You can mark the hands of your electric clock, make your luminous other articles, make your own Luminous Crucifixes, Luminous Hourglasses, etc. Small bottle, price **25c**. Larger sizes, 50c and 80c postpaid. Johnson Smith & Co.

Mystic Skeleton

A printed figure 10c. The skeleton is made of paper and is so constructed that it can be made to look like a real skeleton. It is a wonderful toy for children and a curiosity for the general public. Price **10c**.

All the Latest Surprising and Joke Novelties

- Chicken Inspector's Badge 15c
- Crowd King of King 25c
- Walrus Tooth of Amap 10c
- Aarabie Bomb (Express only) 80c
- Box of Toys 10c
- Book of Boxes 50c
- Turkey's wonderful Trick Cards 10c
- Box of Wire Pencil 10c
- Smoker's Basket of Magic Tricks 75c
- Watch Chain 10c
- Flips for Watch Chains 10c
- Weather Camera 10c
- Weather Camera 10c
- Refractoscope (see behind you) 25c
- Amateur Electrician 10c
- Electricity (Express only) 80c
- 10c for 10c

JOHNSON SMITH & CO., Dept. PMS5, 3224 North Halsted Street, CHICAGO

Build Your Own PHONOGRAPH

IT'S EASY WITH OUR HELP A few hours interesting work saves over half and gives you a machine to suit your ideas. We furnish motors, tone arms, case material, blue prints and full instructions. Plays any record. Make fine profit building phonographs for your friends. Write today for our FREE Blue print offer. Price per box, 15c each.



Agents King Phonographs
Choraleon Phonograph Co.
1220 3rd St., Elkhart, Ind.

\$4 AND \$5 WILL BUY a month A Standard, Guaranteed TYPEWRITER

With Every Modern Writing Convenience. WRITE TODAY FOR ILLUSTRATED CIRCULAR Explaining Try-Before-You-Buy Plan. HARRY A. SMITH, 738-218 North Wells St., Chicago, Ill.

Learn to Dance!

You can learn Fox-Trot, One-Step, Two-Step, Waltz and latest "up-to-the-minute" society dances in your own home by the wonderful Peak system of Mail Instruction. New Diagram Method. Easily learned; no music needed; thousands taught successfully. Write for Special Terms. Send today for FREE information and surprisingly low offer. WILLIAM CHANDLER DEAR, R. R. BOX 239 - 621 Crescent Place - Chicago, Ill.



"EARN WHILE YOU LEARN"

STUDY ART

Learn to create illustrations, designs, posters or costume drawings. The business world demands them and offers big returns to trained artists.

We teach Composition, Perspective, Technique in pen-and-ink, water-color, etc., fascinating Design studies, Historic Ornament and Lettering, as well as Color.

Advanced classes are Costume Illustration, Advertising Art, Photo-Retouching.

Home Study and Resident instruction both given. Our catalogue on request.

COMMERCIAL ART SCHOOL

708, 116 S. Michigan Avenue



Electricians, Carpenters, Bricklayers, Mechanics, Shipyard, Sheet Metal, Structural and Concrete Workers, Boiler Makers, Plumbers, Pipefitters and others can earn big money if they can read Blue Prints. Get into the big-pay class. By our simple method we train you in a short time. Write for Catalog 15-B, stating trade. Do it today.

BE A DRAFTSMAN

Earn \$35-\$150 a Week

Employers everywhere are looking for draftsmen. They are offering big salaries and good positions are always open. By our practical method we train you quickly in your spare time. Drawing outfit, books, etc., furnished FREE. We help you to obtain position when qualified. Write for Catalog 15-G. DO NOT DELAY.

COLUMBIA COR. SCHOOL

Dept. 1, Drexel Bldg., Phila.

Help Wanted

We require the services of an ambitious person to do some special advertising work right in your own locality. The work is pleasant and dignified. Pay is exceptionally large. No previous experience is required, as all that is necessary is a willingness on your part to carry out our instructions.

If you are at present employed, we can use your spare time in a way that will not interfere with your present employment—yet pay you well for your time.

If you are making less than \$150 a month, the offer I am going to make will appeal to you. Your spare time will pay you well—your full time will bring you in a handsome income.

It costs nothing to investigate. Write me today and I will send you full particulars by return mail and place before you the facts so that you can decide for yourself.

ALBERT MILLS, Gen. Manager Employment Dept. 2714 American Bldg., CINCINNATI, OHIO

MEN

Intensely interesting booklet free.

Wonderful results.

H. Gyde Co., Washington, D. C.

Why continue to STAMMER?

Send for (free) illustrated 200-page book. It tells how Stammering and Stuttering can be quickly cured by the most Advanced Scientific Method in the world. THE LEWIS SCHOOL, 40 Adelaide, Detroit, Mich.

sation. With one of two exceptions the elements composing organic beings fall in the first two staffs of the periodic law. That is no coincidence. Living things seem to make special atoms of the proper weight and reactivity to carry on the functional activities of the body. If that is true, then we must learn to aid electronic condensation going on in the organism before we bother with chemical reactions, which are then secondary and not primary phenomena of life, if ever we are going to have a scientific system of therapeutics. In my laboratory out on the ranch I have for years investigated marine animals and plants, as well as land organisms, and I find that many of them contain elements which do not exist in their immediate environment. Transmutation of atoms must then take place, if in truth new atoms are not formed.

"Our food builds our frame-work and acts as catalyzers in the production of highly complex enzymes, the nature of which is almost wholly unknown to medical science. 'The well established laws of chemistry' have given to physicians little more than the requisite Latin terminology with which to hide their ignorance. The hope for our profession lies, in the new, electro-dynamics. The radio-activity of matter will be the lamp to guide our feet on the path of discovery and into the truth of life. Instead of seeking for mineral or bacterial ingredients with which to control disease processes, we must learn to use magnetism and heliotropism to regulate life processes. Until this is done we'll continue to operate where we ought to cure, and I might add that whenever we use the knife for anything but traumatic conditions, we reveal our helpless ignorance of the fundamental processes of life. But we need not despair. The dawn is breaking. We are on the road to the source of light. But this is a little beside the question.

"What I am trying to accomplish in this world, is to add if possible a few facts to this world's store of truth. A new fact discovered is of more importance to the human race than a million stomach-aches assuaged or a million dollars amast. My researches carry me quite beyond the merely therapeutic; they tend to point the way to the solution of some of our greater social, I might say racial, problems. The culturing of flesh for instance from condensations of sea water, which will some day be perfected, will solve the protein food problem and that problem is very important if my butcher's bills are any indication. The fact is, that due to the highly efficient methods for the production of life's necessities, the human race is increasing by leaps and bounds. The increase of human numbers naturally decreases the animal range, yet increases the demand for animal food. There is only one way to solve it and that is along the line of my experiments.

"By the artificial culture method, flesh and fats could be produced free from disease taints and marketed locally in an absolutely fresh condition; that would do away with the deterioration going on in cold storage flesh which is so prolific a source of disease in modern society."

He showed me a bottle similar to the one in which he had planted the muscle of a dog; in it I saw a bright red mass afloat in a pale yellow fluid. "That is porterhouse," he explained. "I planted it a week ago, then it weighed one ounce, now it weighs three and one-half pounds and is pure meat; and what is more important to me, it grows unassociated with a highly sensitive organism. This idea of wholesale butchery, as carried on in our modern slaughter houses, is unesthetic to say the least."

As he referred to the brutalizing effect of killing, I could not help but remember the dog he was so industriously carving when I came in; but I made no comment.

10 Lessons in PUBLIC SPEAKING FREE

Write quick—for particulars of this extraordinary offer; an offer you will never forget if you take advantage of it: Ten lessons in Public Speaking absolutely free to those who act promptly. We make this extraordinary offer to introduce our wonderful course in localities where it is not already known.

We teach you, by mail, to become a powerful and convincing talker and speaker—to dominate and control the decisions of one listener or an audience of a thousand. We have trained hundreds and helped them to increase their earnings and their popularity. Learn in your spare time, at home, how to overcome "stage-fright" and conquer fear of others; how to enlarge your vocabulary; how to develop self-confidence and the qualities of leadership; how to RULE others by the power of your speech alone; how to train your memory. Our

New, Easy Method

perfected and taught by Prof. R. E. Pattison Kline, former dean of the Public Speaking Department of the Columbia College of Expression, can be learned in 15 minutes a day. Prof. Kline is one of the foremost authorities in the country on public speaking and mental development. Do not delay and miss this opportunity of a lifetime.

OFFER LIMITED SEND NO MONEY

This Special Offer of ten lessons free is made strictly for advertising purposes and will be withdrawn without notice. Write now, before it expires, and receive full particulars with enrollment blank by return mail. Just tear off and mail free coupon—or a postal.

NORTH AMERICAN INSTITUTE
9449-3601 Michigan Ave., Chicago

Send This Free Lesson Coupon

NORTH AMERICAN INSTITUTE,
9449-3601 Michigan Ave., Chicago, Ill.
I am interested in your course in Effective Public Speaking and your offer of 10 lessons free. Please send full particulars. This request places me under no obligation of any kind.

Name.....
Street.....
City.....
State.....

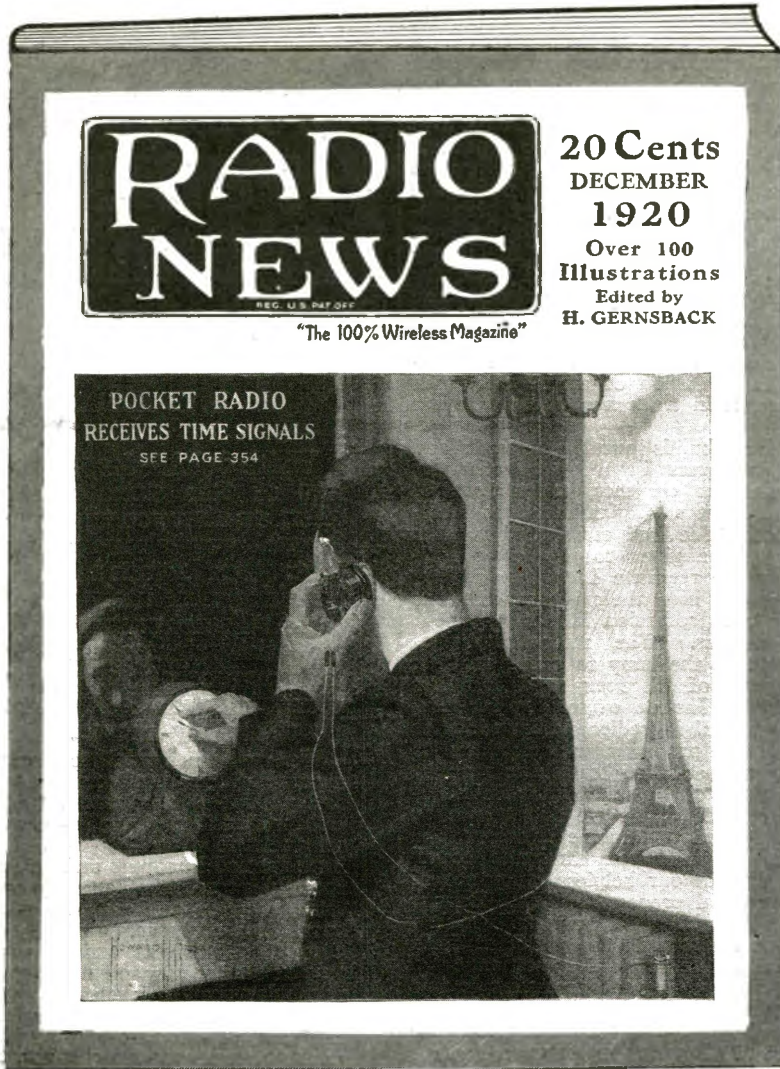

“THE 100% WIRELESS MAGAZINE”

What “Radio News” Is:

RADIO NEWS now in its second year holds the field undisputably as the greatest radio magazine in print today. In point of circulation, number of articles, illustrations, RADIO NEWS leads all other wireless magazines. The November issue had 72 pages; there were seventy separate purely radio, articles and 112 illustrations. Over forty thousand copies were printed and circulated.

Each issue of RADIO NEWS contains 74 pages (or more) and an artistic cover in two colors. The illustrations average 120 every month and there are from 60 to 80 up-to-date articles, some by our greatest radio scientists, in every issue.

20c
The Copy
\$2.00
A Year
 Canada and Foreign
\$2.50 A Year

SEND
20c FOR
SAMPLE
COPY
TODAY

\$50.00

PRIZE CONTEST

See the November issue and our special cover. \$50.00 if you send in the best title for the picture.

72 PAGES
120 ILLUSTRATIONS

EXPERIMENTER PUB. CO.

231 Fulton St., New York City

SPECIAL OFFER

Gentlemen:
 Please enter my subscription for RADIO NEWS for the term of one year for which I enclose herewith \$2.00. As a special offer you will also send me for 25c extra your great Wireless Course containing 160 pages, 350 illustrations, size 6 3/4 x 10" with fine flexible cloth cover. I have written my name and address in margin at the left.

Practical Chemical Experiments

(Continued from page 913)

pieces about a half-inch long. Put these in a 15-inch length of combustion tubing arranged as shown in figure 2 and connected with an oxygen generator. Under the tube place a 4-tube Bunsen burner. Heat the wire and at the same time pass over it a stream of oxygen from the generator. Bring the copper to a good heat before starting to heat the generator. Prepare the oxygen in the usual way by heating a mixture of potassium chlorate and manganese dioxide.

When the copper wire has turned to black copper oxid turn off the burners, disconnect the oxygen generator and allow the tube to cool. Remove a few pieces of the black wire and note their lack of lustre and flexibility. Break a piece and observe that the wire has become black and brittle thruout.

Now set up a hydrogen generator and connect it to the combustion tube containing the copper oxid as shown in figure 3. Upon the zinc in the hydrogen generator pour dilute sulfuric acid, and after all the air has been swept from the apparatus, light the four-tube burner under the combustion tube. As the stream of hydrogen passes over the hot copper oxid it unites with the oxygen in the oxid to form water, which escapes as steam, and there is left in the tube bright metallic copper.

Thus by heating copper in oxygen and reducing the product with hydrogen back to metallic copper, accompanied by the formation of water, we have proved that copper oxidizes. Incidentally we have also proved the composition of water.

Great Activity of some Metals: The two most active metals are potassium and sodium, the two least active are platinum and gold. The two former are so active that they will decompose water with the liberation of great energy and therefore must be kept under kerosene.

Buy an ounce of each of these two metals. They will probably come in small sealed containers. Before opening them have ready two small wide-mouthed bottles containing kerosene. Then upon removing the metals immediately immerse them in the kerosene.

Remove the potassium from the kerosene and with your knife blade cut off a very small piece. Note the softness of the metal and the bright lustre of the freshly cut surface. But also observe that this bright surface immediately tarnishes owing to the very great affinity of potassium metal for oxygen.

Now throw the small piece of potassium upon the surface of water in a small cup or beaker. So light is the metal that instead of sinking it floats, and so great is its activity that immediately it begins to liberate hydrogen from the water and both the hydrogen and potassium take fire. As you watch, a molten globule of shining metal skims about over the surface with a hissing sound and growing rapidly smaller is soon consumed.

To show that a new substance has formed in the water add to it a few drops of phenolphthalein indicator and a beautiful pink color showing the presence of a base appears.

Repeat the above operations with sodium and similar results will be obtained, except that the sodium will not take fire.

These were the two first metals to be discovered by means of the electric current and it is said that when Sir Humphrey Davy saw the bright globules of molten potassium separating at the cathode of his apparatus, his delight knew no bounds and he danced about his laboratory like a madman for sheer joy.

(Continued on page 939)

10c
OR
25c

Anti-kamnia

FOR HEADACHE, NEURALGIA, INFLUENZA AND ALL PAIN

AK

Ask For A-K Tabs

TABLETS



Edited by
H. Gernsback

In this Department we publish such matter as is of interest to inventors and particularly to those who are in doubt as to certain Patent Phases. Regular inquiries address to "Patent Advice" cannot be answered by mail free of charge. Such inquiries are published here for the benefit of all readers. If the idea is thought to be of importance, we make it a rule not to divulge all details, in order to protect the inventor as far as it is possible to do so.

Should advice be desired by mail a nominal charge of \$1.00 is made for each question. Sketches and descriptions must be clear and explicit. Only one side of sheet should be written on.

IMPORTANT NOTE TO CORRESPONDENTS

We receive from thirty to fifty letters requesting advice on patents every month. Due to lack of space, even the condensing this department into the smallest type, we can only publish from eight to ten letters, with their answers, monthly. Obviously we are falling back further and further, and it looks as tho we will never be able to publish all the requests.

For this reason we would urge correspondents to avail themselves of our special service, as outlined above. In that case an immediate answer will be assured.

EDITOR.

GLASS BATTERY JARS

(427) W. G. Downie, Pomeroy, Ohio, writes: In my work with storage batteries I have often noticed how easily the rubber jars are broken; also by the action of the solution in batteries on the wood boxes I have noted how soon they fall to pieces. Now, the idea has come to me why not make the whole thing of glass; by this you would do away with the box, also the rubber jars, reducing the cost of a 3-cell battery from \$6 to \$8. Besides you can see at a glance thru the glass what is the trouble in the inside, whether the plates are touching or shorted by sediment in the bottom, positive plates crumbling, etc. I understand there is a glass made now that is very tough, besides the glass used on automobiles is hardly ever broken thru anything but accidents. I had started on getting a patent on same, but before I do so I would want your advice.

A. The idea which you have of all glass storage batteries is by no means a new one. Several companies manufacture all-glass storage batteries, but these are not satisfactory except for stationary purposes. Glass batteries have been used in Germany and France for many years and were manufactured complete with glass covers, etc., but the trouble with glass storage batteries always is that it is difficult to seal them, because the sealing wax or sealing compound does not stick as well to glass as to hard rubber, for instance. Then there is always the breakage, which is very high. The French and English have a much better battery for such purposes than we have, and they build these batteries out of transparent celluloid, which not only is light but transparent and tough as well.

AMPLIFIER

(428) Martin E. Truska, Brooklyn, N. Y., asks the following:

I would like to have your opinion as to the patentability and practicability of a telephone amplifying device, the drawing of which I enclose herewith. The drawing itself is almost self-explanatory.

The weak pulsating current from the line passes into electromagnets, causing the diaphragms to vibrate. This action is transferred to the granulated carbon by means of carbon discs and rods which extend thru holes drilled in the cores of the electromagnets. This varying pressure on the granulated carbon causes more or less current to flow from the local battery into the receiver. The result is a reproduction and an amplification of the original impulses. This device could also be adapted to the amplification of radio signals, making it unnecessary to have the receivers held against the ears.

A. The idea which you have is a good one, altho the writer personally thinks that you do not gain very much by loading the diaphragms as you do.

While of course an instrument of this kind is sensitive, there have been more sensitive ones designed on a slightly different basis, as for instance the Multiaudiphone. There is, however, a chance that you will get a patent on your device, but before doing so, we would strongly advise you to take up the matter with a patent attorney first, asking him to make a search for patentability. You will then be in a better position to obtain a patent when you know what different devices have been covered in the art heretofore.

RUBBER SHOE

(429) J. N. Roberts, Cleveland, Ohio, requests the following information:

I enclose sketch for half-sole rubber. This is to be made in such a manner so as to fit snug over the sole of the shoe with a small part of the rubber coming over the tip of the shoe and a band over the instep. Also a simple clamp under the arch of the shoe to keep it in place.

My idea of these half-sole rubbers is that they would not be as heavy and clumsy as the ordinary rubbers with heels, as there are days when a person needs just enough protection of the sole to keep the dampness away instead of wearing the full rubbers. Please pass judgment on the idea, and if it could be patented.

A. Your idea of the special rubber for shoes is a good one, and perhaps can be patented. The only thing that worries us is the attachment to hold the rubber on the shoe which you sketch roughly, but of which you have given no lengthy description. As you know, shoes all vary in width at the bottom, and we think you would have trouble to convince the manufacturer that he could make money by getting out such an attachment. The idea is sound, and as you probably know, there exist now women's rubbers made in a similar way except that the strap goes over the heel of the shoe. These rubbers are quite popular with women, and there seems to be a good demand for them.

If the attachment in question is so designed that it will fit every shoe, then you ought to have a very good patent.

PHONO-PIANO

(430) John A. Hupf, Brooklyn, N. Y., asks: I enclose a drawing on which I would like a little advice whether patentable, also how strong a patent can be obtained on same.

It is an instrument in the form of a regular piano, but in place of strings there is a series of disc records, one for each key on the piano key-

U.S. PATENTS

SEND FOR THIS FORM

Don't Lose Your Rights

Before disclosing your invention to anyone send for blank form "Evidence of Conception" to be signed and witnessed. A sample form together with printed instructions will show you just how to work up your evidence and establish your rights before filing application for patent. As registered patent attorneys we represent hundreds of inventors all over the U. S. and Canada in the advancement of inventions. Our schedule of fees will be found reasonable. The form "Evidence of Conception" sample, instructions relating to obtaining of patent and schedule of fees sent upon request. Ask for them,—a post card will do.

LANCASTER & ALLWINE

255 OURAY BLDG., WASHINGTON, D. C.

"Originators of form Evidence of Conception"

PATENTS

TO THE MAN WITH AN IDEA

I offer a comprehensive, experienced, efficient service for his prompt, legal protection and the development of his proposition.

Send sketch, or model and description, for advice as to cost, search through prior United States patents, etc. Preliminary advice gladly furnished without charge.

My experience and familiarity with various arts frequently enable me to accurately advise clients as to probable patentability before they go to any expense.

Booklet of valuable information and form for properly disclosing your idea, free on request. Write today.

RICHARD B. OWEN, Patent Lawyer
164 Owen Building, Washington, D. C.
2276-8 Woolworth Bldg., New York City

PATENTS TRADE-MARKS AND COPYRIGHTS

Before disclosing an invention, the inventor should write for our blank form "EVIDENCE OF CONCEPTION." This should be signed and witnessed and if returned to us together with model or sketch and description of the invention we will give our opinion as to its patentable nature. Electrical cases a specialty.

Our illustrated Guide Book, "HOW TO OBTAIN A PATENT," sent Free on request. Highest References Prompt Attention Reasonable Terms

FREE COUPON

VICTOR J. EVANS & CO., Patent Attorneys

Chicago Offices: 1114 Tacoma Bldg. Pittsburgh Offices: 514 Empire Bldg. Philadelphia Offices: 135 S. Broad St. San Francisco Offices: Hobart Bldg. New York Offices: 1001 Woolworth Bldg.

MAIN OFFICES: 779 NINTH, WASHINGTON, D. C.

Name..... Address.....

CAN YOU

think of a simple, practical idea that will fill one of the many requests we have on file for new inventions? It may mean a fortune for you. Thousands of things are needed RIGHT NOW. Your brains can help. Send today for our great new book—"Inventions and Trade Marks, Their Protection and Exploitation" and learn more about making money from ideas than you ever knew before. It tells many things that are wanted, too. A postal will do—it is free.

PATENTS ADVERTISED For SALE FREE

In INVENTION And MANUFACTURING SUPPLEMENT.

Published for the man with an idea. Send for free sample copy. One year's subscription 50c

We help our clients, without charge, to get the dollars out of their ideas—having facilities none others possess.

Advice free. Don't delay—get the book at once.

AMERICAN INDUSTRIES, INC.

225 Patent Dept., WASHINGTON, D. C.

board, each record fastened onto a sliding collar to be moved against the needle of a reproducer. By striking any key on the keyboard the rod on back end of key, which has a ball bearing at its end against the sliding collar, forces the collar holding the record against the needle.

Each record can contain at least six of the same notes played by the same amount of different instruments, thereby making it a rare novelty besides musical. These records can be replaced any time with little or no trouble. Power can be applied by either spring, foot or electric motor, or it can be fitted with self-playing mechanism. If my idea seems practical, kindly recommend a reliable patent attorney. Thanking you in advance, I remain.

A. We have carefully looked over your invention, which, to say the least, is quite ingenious. The only difficulty that we see is that it will be a very expensive proposition, and then there is also the matter of wearing out the records, which difficulty seems quite insurmountable. You know even the best records wear out quickly. What, then, will happen on the scheme which you propose?

We do not think it is possible to get the quick action necessary on a piano by means of your system. In other words, we are inclined to think that the lack of time element between the needle, the rotating element, and the diafram would be considerable. For instance such a thing as a "trill" which you can readily do on the piano, would seem impossible of accomplishment with this scheme. Then, there is also the complication and cost involved changing needles, records, etc.

ELECTRIC ALARM CLOCK

(431) Francis Michel, Brooklyn, N. Y., writes: Please let me know whether or not a patent can be obtained on an electric alarm clock which at the same time turns on the lights in the bedroom. If so, would there be much demand for such an article? Its use is obvious for people who have to get up while it is dark.

A. We do not think a patent can be obtained on the idea which you mention. It is not sufficiently original for patent purposes, as similar devices have been described in ours as well as other magazines many times in the past, and for this reason we are quite certain that you could not obtain a patent.

LOCK NUT

(432) H. H. Ellsworth, Racine, Wis., wishes to know:

I wish to take advantage of your patent advice section in regard to the practical and commercial side of the device, a diagram of which accompanies this letter.

As you can see this device consists of a nut so shaped and tapped that when tightened down upon a solid surface, the effect will be to bend the top of the bolt slightly, just enough to exceed the elastic limit of the steel. This will effectively prevent rattling or shaking loose and will in no wise injure the threads of bolt or nut nor hinder the removal of the nut by means of an ordinary wrench.

I had correspondence with a reliable attorney who is of the opinion that this can be patented, yet before investing in legal protection I should like the opinion of someone more versed in mechanics than myself in regard to the device.

A. Your idea, as far as we can see, is a good one. The all-important part that should interest you is, the device practical, and will it work as you think it does? This looks all right to us on paper, but we are afraid you may have some obstacles when you come to actually manufacture the device.

We think it would be much better to make up a few samples and see if they work satisfactorily under all conditions. Then, if you find that this is so, we are quite certain that you will have no trouble in securing a patent.

ALCOHOL MAY TAKE THE PLACE OF "GAS."

Alcohol as a substitute for gasoline is being investigated by the British Government and tests are being made for the purpose of determining to what extent it can be used.

It is believed that the Board of Customs and Excise will shortly approve the denaturing of alcohol for power purposes. At the present time it can only be used with the addition of 5 per cent methyl—which adds at least twenty cents per gallon to its cost when used as fuel.

Tests have been made by the London General Omnibus Company, which corporation put out a small fleet of motor buses operating on alcohol mixed with benzol, to the exclusion of gasoline. The results of the tests are stated to have been most satisfactory.



FLYING MODEL AIRPLANES
—JUST OUT—
OUR NEW CATALOGUE 52 PAGES
Wadingworth Mfg. Co.
EST. 1909.
672 B-WAY B-KLYN, N.Y. SEND 10 C. FOR ONE

INVENTORS HAVEN'T YOU SOME IDEA

that you can't just work out? Give us the idea—we will develop it for you. Mechanical and electrical ideas developed. Experts in model and experimental work and in perfecting inventions. Designing and building labor-saving machinery a specialty. Get in touch with us—we can save you money.

ELK MFG. CO., INC.
1926 Broadway, New York

PATENTS

Write for free INVENTOR'S RECORD form for establishing the date of your invention, and INVENTOR'S BULLETIN Confidential Service

WM. H. MULLIGAN, PATENT LAWYER
110 Woodward Bldg. Washington, D. C.

PATENTS

Hand Books on Patents, Trade Marks, etc., sent free. Our 70 years of experience, efficient service, and fair dealing, assure fullest value and protection to the applicant. The Scientific American should be read by all inventors.

MUNN & CO., 618 Woolworth Bldg., N. Y.
Tower Bldg, Chicago, Ill. 225 F St, Washington, D.C. Hobart Bldg., 582 Market St., San Francisco, Cal.

PATENTS

If you have an invention and desire to secure a patent, send for our Free Guide Book, HOW TO GET YOUR PATENT. Tells our Terms, Methods, etc. Send model or sketch and description for our opinion of its patentable nature.

RANDOLPH & CO.
Dept. 172 Washington, D. C.

PATENTS & TRADE-MARKS

FREE BOOKLET ON REQUEST — MY CLIENTS ARE INFORMED OF EVERY STEP TAKEN IN THE PROSECUTION OF THEIR CASES —

WARNER I. CUBBERLEY, PATENT ATTORNEY
22 NATIONAL UNION BUILDING WASHINGTON D.C.

WILLIAM C. LINTON
Consulting Engineer and Patent Attorney

"Inventor's Adviser" mailed free on request. Gives full information as to Patents, Trade Marks and their Cost.

OFFICES
364 University St. 919 F St., N. W.
Montreal, Canada Washington, D. C.

PATENTS

C. L. PARKER
Formerly Member Examining Corps, U. S. Patent Office.
PATENT LAWYER
McGill Bldg. Washington, D. C.

Patents, Trade Marks, Copyrights, Patent Litigation

Handbook for Inventors, "Protecting, Exploiting and Selling Inventions," sent upon request.

Free Book on PATENTS

Contains valuable information and advice to inventors on securing Patents. Send model or sketch of your invention for Free Opinion of its patentable nature. Prompt service. 20 years experience. Write today.

TALBERT & TALBERT 4287 TALBERT BLDG., Washington, D.C.

U.S. PATENTS

PROTECT YOUR RIGHTS

RECORD OF INVENTION

J REANEY KELLY

Write for "Record of Invention" containing forms establishing evidence of conception. Send sketch and description for report upon patentable nature, and instructions. Preliminary service without charge.

PROMPT PERSONAL SERVICE

J. REANEY KELLY

PATENT ATTORNEY
892 SOUTHERN BLDG.
WASHINGTON D.C.

PATENT-SENSE

The Book for INVENTORS and MANUFACTURERS

SIXTH EDITION

The Book for Inventors and Manufacturers

SIXTH EDITION.

By return mail FREE. Write LACEY & LACEY Dept. K, Washington, D.C.

PATENTS

Send sketch or model for preliminary examination. Booklet free. Highest references. Best results. Promptness assured. Watson E. Coleman, Patent Lawyer, 624 F St., Washington, D. C.

“The Greatest Radio Catalog in the World—”

The Universal Verdict of Tens of Thousands of Radio Amateurs

DUCK'S No. 14 Big 200 Page Wireless Catalog

A VERITABLE Treasure House of Everything Worth While and Dependable in Radio. The largest, most comprehensive, artistic and educational wireless catalog published. The Beacon Light to

guide you right in the selection of your radio purchases, and at prices that will command your attention. Every instrument guaranteed with privilege of return if not satisfied.

Mail 12c in stamps or coin (not sent otherwise), which amount you are privileged to deduct on first dollar purchase. Revised price list to first edition of catalog, with prevailing prices, mailed on request.

Announcing the Original “Duck” Service

Practically every order being shipped within 24 hours after receipt

Tremendous Christmas Stocks—

WITH a business of unprecedented volume ever since the close of the war. With nothing short of miserable service from our many sources of supply, and many other unusual conditions to contend with, we found it impossible, up to a comparatively short time ago, to give the service on orders for which we always enjoyed such a high reputation, and which was our pride. We deliberately curtailed our advertising, because we could not get catalogs printed fast enough and because we did not want a volume of business we could not expeditiously handle. We are now able to guarantee the wonderful service that our thousands of patrons received for many years before the commencement of the war.

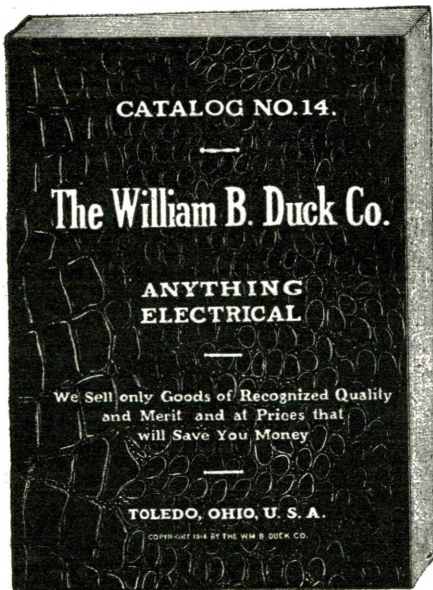

Send 12c for this wonderful catalog today. Revised price list to first edition of catalog No. 14 mailed on request.

3 Big Specials

November 15 to December 15

DURING the above period, planning on a terrific demand, we are placing truly remarkable prices on three of our most popular radio

instruments. These low prices are possible only because of tremendous quantity production.

Model 5BB Navy Type Receiving Transformer, Regular price \$27.50. Special Price only \$21.95

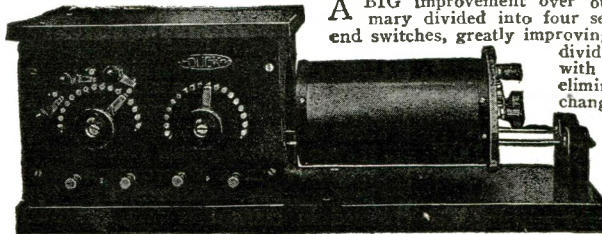

A BIG improvement over our former model. Primary divided into four sections, with three dead end switches, greatly improving selectivity. Secondary divided into three sections, with two dead end switches, eliminating harmonics. The change in the construction of the guide rod support makes it possible to obtain a looser coupling. It is a wonderful improvement over our old model, both in appearance and performance.

Improved Arlington Receiving Transformer, Regular price \$15.00. Special Price only \$11.95

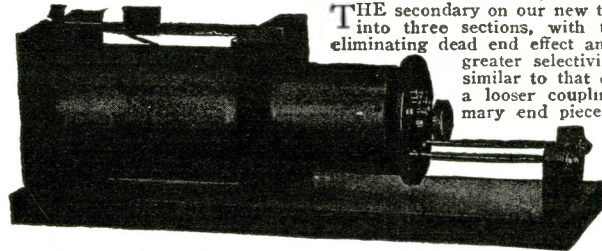

THE secondary on our new type Arlington is divided into three sections, with two dead end switches, eliminating dead end effect and harmonics and giving greater selectivity. The end support is similar to that on our Navy, permitting a looser coupling. The base and primary end pieces have a spline to prevent warping or damage in transit. This feature is also on our Navy. It is a beautifully finished instrument.

Improved Type Sayville Rotary Gap

Embodies the latest and best features in Spark Gap Construction.

Our New Type Sayville Rotary Gap is, we believe, far in advance of any rotary gap on the market within a range even of twice the price. It is the final development of many different types made in our experimental Radio Laboratory. It fulfills every requirement of the ideal rotary gap. It is neat and attractive in appearance; simple and durable in construction; possesses a wonderful motor; has a cast aluminum rotary wheel, beautifully polished; every part is in perfect alignment; there is no wobbling of the rotor; produces and maintains a clear and pure 500-cycle note; is instantaneous in action; permits of no dragging of the spark; has contacts of tempered flat copper of proper length and width, easily and quickly removable, and inexpensively renewable; the stationary contacts are adjustable to any length. **Price \$27.50**

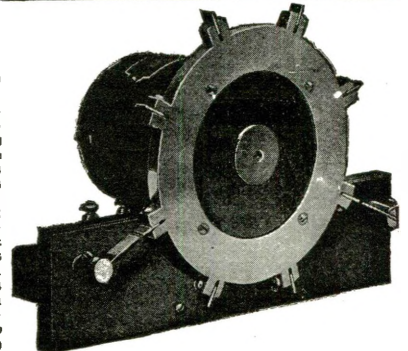

No. 7721 Receiving Transformer, Regular price \$9.00. Special Price \$7.50

THE WILLIAM B. DUCK CO., 230-232 Superior St., Toledo, Ohio

Go to School at Home!

HIGH SCHOOL COURSE IN TWO YEARS

You Want to Earn Big Money!

And you will not be satisfied unless you earn steady promotion. But are you prepared for the job ahead of you? Do you measure up to the standard that insures success? For a more responsible position a fairly good education is necessary. To write a sensible business letter, to prepare estimates, to figure cost and to compute interest, you must have a certain amount of preparation. All this you must be able to do before you will earn promotion.

Many business houses hire no men whose general knowledge is not equal to a high school course. Why? Because big business refuses to burden itself with men who are barred from promotion by the lack of elementary education.

Can You Qualify for a Better Position?

We have a plan whereby you can. We can give you a complete but simplified high school course in two years, giving you all the essentials that form the foundation of practical business. It will prepare you to hold your own where competition is keen and exacting. Do not doubt your ability, but make up your mind to it and you will soon have the requirements that will bring you success and big money. **YOU CAN DO IT.**

Let us show you how to get on the road to success. It will not cost you a single working hour. We are so sure of being able to help you that we will cheerfully return to you, at the end of ten lessons, every cent you sent us if you are not absolutely satisfied. What fairer offer can we make you? Write today. It costs you nothing but a stamp.

American School of Correspondence
Dept. H-926 Chicago, U. S. A.

American School of Correspondence,
Dept. H-926, Chicago, Ill.

I want job checked — tell me how to get it.

.....Architect	\$5,000 to \$15,000Lawyer	\$5,300 to \$15,000
.....Building Contractor	\$5,000 to \$10,000Mechanical Engineer	\$4,000 to \$10,000
.....Automobile Engineer	\$4,000 to \$10,000Shop Superintendent	\$3,000 to \$7,000
.....Automobile Repairman	\$2,500 to \$4,000Employment Manager	\$4,000 to \$10,000
.....Civil Engineer	\$5,000 to \$15,000Steam Engineer	\$2,000 to \$5,000
.....Structural Engineer	\$4,000 to \$10,000Foreman's Course	\$2,000 to \$4,000
.....Business Manager	\$5,000 to \$15,000Photoplay Writer	\$2,000 to \$10,000
.....Certified Public Accountant	\$7,000 to \$15,000Sanitary Engineer	\$2,000 to \$5,000
.....Accountant & Auditor	\$2,500 to \$7,000Telephone Engineer	\$2,500 to \$5,000
.....Draftsman & Designer	\$2,500 to \$4,000Telegraph Engineer	\$2,500 to \$5,000
.....Electrical Engineer	\$4,000 to \$10,000High School Graduate	\$2,500 to \$5,000
.....General Education	In one yearFire Insurance Expert	In two years \$3,000 to \$10,000

Name.....
Address.....

The Light Ray Phonograph
(Continued from page 851)

the electric light ray it is bound to produce the same number of vibrations as the latter.

In the event that the claims which Mr. Lauste makes for his Electro-Phonograph come true, the machine will give a new impetus to the talking picture industry. The songs of the world's great artists will then be in great demand and it will be possible for those who live in obscure and faraway places on this globe to procure the treats which now are only afforded those who can listen to the singers in theaters, concert halls or operas. Of course, we have records of our famous singers, speakers, and orchestras, but as aforementioned, the present-day type of phonograph records do not give the full, natural reproduction of tones which are claimed for the records made by Mr. Lauste's instrument.

This new apparatus opens another field of great importance. Since the sound is collected by means of the microphone, which necessarily does not have to be attached directly to the instrument, but can be located any distance away, the Electro-Phonograph can take the place of the dictograph in secretly obtaining a record of speech or conspiracy uttered by persons suspected of some crime. As a matter of illustration let us imagine a group of persons gathered together in a room planning some act of violence against society. It may be difficult for detectives to enter and obtain evidence while the men are in session. In such a case it would be only necessary to install a microphone, properly camouflaged, in some part of the room or rooms, while the suspects were absent, and then when the latter gathered to discuss their seditious plans, their speech could be recorded on a phonograph disc at police headquarters. Where the dictograph is used in cases like this, shorthand writers generally listen in and make notes of whatever conversation or talk is taking place. This method opens up great possibilities for eliminating errors, since there are times when it is difficult to hear all of the conversation. Something of importance might be mist by the shorthand writer.

This invention would also prove of immense benefit to newspapers in securing quickly and accurately news of the day. Speeches of conventions, important meetings, or court proceedings could be obtained very handily by means of the Electro-Phonograph. The latter would have its place in the room of the city editor, while the microphones in different parts of the city would carry to the instrument the proceedings as recorded in the places mentioned.

Mr. Lauste uses in the apparatus shown in the accompanying photograph, a very similar device now to that used in the ordinary motion picture studios, except that a phonographic disc is mounted in an upright position and the beam of light directed against a plate of special composition, fixt to the disc, literally melts the composition and in that way, due to the oscillating beam of light, cuts transverse grooves into the record in very sharp forms, and is thus able to secure, not alone the overtones, but more music on each record.

Not alone is Mr. Lauste working on this scheme, but there are several others equally if not more important. One of the features which he has worked upon for upward of 20 years, is talking motion pictures, and thru a simple compressed air amplifier, he has been able to reproduce sound from film with wonderful clarity and so loud that it could be heard thru several large rooms.

MAKE YOUR OWN MACHINE FOR TELEGRAPHING PICTURES

Something never offered before — secret, blue print and complete instructions for most marvelous invention of the age. Machines easily and inexpensively made from material and simple articles already in the hands of every experimenter. Will transmit pictures, maps, drawings and handwriting. This picture transmitted on set of these machines. Only \$2. Send today.

L. J. LEISHMAN CO.
Dept. F Ogden, Utah



ALL MAKES

Underwoods, Monarchs, Remingtons, L. C. Smiths, Oliviers, Royals, Coronas AT
REDUCED PRICES. \$2000
Prices as low as...
Write for our Catalog No. 15
BERAN TYPEWRITER CO.
Dept. 21, 58 W. Washington Street, Chicago

"Lighting Fixtures"
Ready to Hang
(Direct from Manufacturers)
Completely wired, including glass-ware. New designs.
Send for catalog No. 20
ERIE FIXTURE SUPPLY CO.
Sta. C Erie, Pa.

BUILD A WHITE FIREFLY \$2.00
CARRIES FULL GROWN MAN
World's lightest and simplest airplane. Designed by George D. White, America's foremost aeronautical engineer. Weight 150 pounds, length 15 ft. Needs 8-12 H.P. motorcycle engine. Lands and takes off at 24 miles per hour. Useful load 165 pounds. Can be built in a few weeks at home. Send \$2 for complete working drawings, building instructions and price list of parts. **SEND \$2 NOW!**

WHITE AIRCRAFT WKS.
Dept. 18, 425 Merchants Trust Bldg., Los Angeles, California.

WHISPER INTO THIS!
Price \$1.10
and your voice will carry, clear and audible, to the other end of the line. This Marvelous New Standard Mouth-piece insures perfect results on any phone. If you want to reduce telephone troubles, get the magic
THERAPHONE
The effect is startling. Eliminates repetition, clears the air. A real energy saver. Check or C. O. D.
The EVOLUTION PHONE COMPANY, Inc.
488 Greenwich Avenue, New York City

Foreign \$1.25

GIVEN
Also your choice of many real valuable and useful presents, given for distributing a few packages of the wonderful Majie Dye Soap Flakes at 10c. It's a snap to get a present. Every woman wants these wonderful home dyes. It's easy to distribute these wonderful home dyes — and we trust you fully and help you in every way. Send your name and address at once.
FREE SALES CO., Dept. 20 CHICAGO

MARKO STORAGE BATTERIES
ARE GOOD—TRY ONE
Paul M. Marko & Co., Inc.
1402-1412 Atlantic Ave.
Brooklyn, N. Y.

FREE This REPAIR OUTFIT is given to you for selling only 40 packs "Quality Brand Garden Seeds" at 10c. per packet. Order today. **SEND NO MONEY. WE TRUST YOU.** When sold return \$4.00 collected and the REPAIR OUTFIT is yours. Cash commission if preferred. Many other valuable presents. Catalogue with order.

NATIONAL SEED CO., Dept. 126, Lancaster, Pa.

5 Master Keys
Have a set of the most wonderful keys in the world, which open hundreds of different locks and replace hundreds of different keys. Used by locksmiths, janitors, and detectives. Set and novel key chain sent for \$1.00. Master Key Company, 42 Manhattan Bldg., Milwaukee, Wis.

I TEACH BY MAIL
"WRITE FOR MY FREE BOOK
"How to Become a Good Penman"
and beautiful specimens Your name elegantly written on a card if you enclose stamp. Write for it today. F. W. TAMBLIN, 424 Meyer Bldg., Kansas City, Mo.

BE A BANKER
Prepare to mail in spare time for this attractive profession, in which there are great opportunities. Send at once for free book, "How to Become a Banker"
EDGAR G. ALCORN, President
American School of Banking, 114 McLene Bldg., Columbus, O.

RADIOTRONS VACUUM TUBES for Amateur or Experimental Use

THE facilities and resources of the world-famous RESEARCH LABORATORIES of the General Electric Company have been concentrated upon the development and design of a new series of VACUUM TUBES for Radio Detection and Amplification. The RADIO CORPORATION OF AMERICA now offers to the Wireless Experimenter two distinct types, each adapted to a particular field of usage.



LIST PRICE
\$5.00



LIST PRICE
\$6.50



Standard Grid Leak

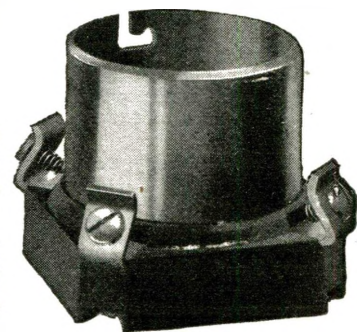

Standard Vacuum Tube Socket

RADIOTRON U. V. 200, the first of the series, is a Detector and Audio Frequency Amplifier of unusual capabilities, which operates from a single standard plate battery. Best detector action occurs at plate voltages between 18 and 22½ volts, with a filament current of approximately 1 ampere, and with a grid condenser and grid leak. U. V. 200 is particularly adapted to amateur regenerative circuits. A trial in such circuits will be the most convincing.

NOTE—A special "A" or filament battery potentiometer for close adjustment of the plate voltage of U. V. 200 will shortly be placed on the market by the Radio Corporation.

RADIOTRON U. V. 201, the second of the series, is an unexcelled Amplifier of the PLIOTRON type, which may be used for Detection and for Radio or Audio Frequency Amplification. Normal plate voltage, 40 (two standard "B" batteries). Voltages up to 100 may be used on the plate with increasing amplification. Amplification constant, 6.5 to 8 at 40 volts on the plate, 8 to 10 at 100 volts on the plate.

Note to Amateurs, Dealers and Jobbers

Radiotrons are manufactured by ultra-scientific methods laid down by America's foremost tube experts. No guess work—each tube bears the stamp of electrical manufacturers of world-wide reputation. A uniform product is assured. All tubes fitted with standard four-prong base. Filaments operate from 6 volt battery with rheostat.

LIST PRICES

Radiotron U. V. 200 . . .	\$5.00
Radiotron U. V. 201 . . .	6.50
Standard Vacuum Tube Socket . . .	1.00
Standard Grid Leak Mounted . . .	
100,000 ohms to 6 megohms . . .	1.25
Grid Leak Unit75
Grid Leak Mounting50
Audio Frequency Transformer	7.50

A complete line of vacuum tube ACCESSORIES are now in manufacture and will shortly be available.

Dealers and jobbers: We have an especially attractive proposition for you. Write us at once.

The Radio Corporation's tubes are covered by patents dated November 7th, 1905, January 15th, 1907, and February 18th, 1908, as well as by other patents issued and pending. Tubes licensed for amateur and experimental use only. Any other use will constitute an infringement.

Address all orders and enquiries to
SALES DIVISION

COMMERCIAL DEPARTMENT, Radio Corporation of America
233 Broadway, New York City

Positively Your Last Opportunity

to purchase the Original Tubular,
Vacuum Detector, Amplifier, Oscil-
lator so well known as the double-
filament, double-life, hand-made

AUDIOTRON

In Constant Service Since 1915

AUDIOTRONS, recognized as the most sensitive detectors ever produced, are now free and clear of all patent difficulties. By agreements entered into with Radio Corporation of America, AUDIOTRONS are manufactured under the following patents: Nov. 7, 1905; Jan. 15, 1907; Feb. 18, 1908. Licensed only for amateur or experimental uses in Radio communication. Any other use will be an infringement of the above patents.

AUDIOTRONS are no longer limited to audio frequency and can now be used as detectors and oscillators as well as amplifiers.

See your dealer at once, or order direct. Be sure to benefit by this last opportunity to secure a hand-made, super-sensitive, double-filament AudioTron Detector, Amplifier, Oscillator. Insist on the name AudioTron on every tube you purchase. Fully guaranteed.

\$6.00
Each. No increase
in price

Dealers and Amateurs—Send at once
for advance information on the NEW

AUDIOTRON AMPLITRON OSCILTRON

DETECTOR AMPLIFIER OSCILLATOR

mounted on the standard four-prong base. These NEW TUBES will be ready for delivery about October tenth. A valuable bulletin on these new fully licensed tubes is

now being prepared. See your dealer today. If he cannot supply this Free Bulletin, send us his name and address and we will mail you an advance copy of Bulletin No. P170.

DEALERS, JOBBERS—If you are not on our mailing list, write us immediately

AUDIOTRON MANUFACTURING COMPANY

Dept. S, 35 Montgomery Street (Successors to The AUDIOTRON Sales Co.) San Francisco, Calif.

Building Machines Accurately By EARLE W. GAGE (Continued from page 877)

and these limits, by the way, are far more exacting than are employed in the manufacture of many other machines.

Since it is impossible to make any two parts alike, the workmen steadily strive to make the parts with as slight difference as possible. Only slight variations, as small as the half-thousandth of an inch, are permitted in high-grade modern machines. This brings up the interesting subject of the various instruments employed in making the measurements determining the exact size of these parts.

It may have been determined that a certain part should be permitted to vary only two-thousandths of an inch from the standard. But if the means of measurement are another two-thousandths of an inch inaccurate, there may be a four-thousandths error in the part which, in close fitting, might prove a serious error. So having determined the variations permissible from the exact size, it is necessary to have instruments that actually measure accurately. It is necessary to measure inside and outside diameters, widths and lengths, and whether screw threads have the proper pitch. Close standards are worthless if measured by poor gages; so having set the policy of manufacturing close standards, modern manufacturers must also be equipt with accurate instruments for making the various necessary tests and measurements.

TESTING "HARDNESS" WITH PRECISION.

The *scleroscope*, for example, which tests the hardness of steel by the degree of rebound of a tiny ball of metal that is dropt from a fixt height to the surface of the metal, rebounding within a glass tube on which graduations are marked, the reading being made thru a magnifying glass. Every part of the machine in which hardness is essential is tested by the scleroscope and if it fails to pass the test is at once "rejected."

The dial gage is another interesting instrument which is used to determine whether or not a part supposed to be round is really round, the indicator registering fluctuations of a *thousandth of an inch* as the part is revolved. The registering arm of the device is set in contact with the part to be tested and the dial then turned so that the pointer stands at the zero mark. Movements of the pointer to right or to left indicate whether there are "hills" or "valleys" in the surface. A similar device is used to test cam shafts, the movement of the pointer indicating whether a cam has the proper lift.

The third gage is a two-way gage, providing a means of making both internal and external tests of threading. The external gage or templet is adjustable, so that it can be set to an exact corresponding fit with the internal gage. The external gage can then be used to check up on the accuracy of the threading of a bolt or stud, the internal gage being used to pass upon the threading of the corresponding hole. The end opposite the threaded end of the internal gage is ground and lapt to furnish the exact diameter at the top of the thread. A full stock of these thread gages is used by the inspectors for the various diameters and pitches of the threads they have occasion to test.

THE USE OF THE "PLUG" GAGE.

Plug gages in various sizes are used to test the accuracy of holes of small diameter. Each of these gages has one end .0005 (a half of one-thousandth) of an inch larger than the standard diameter, and the other end .0005 of an inch smaller. In order to pass inspection the holes must be of such size that the small end of the plug will go

(Continued on page 928)

"THERE'S MONEY IN IT"

AT HOME LEARN TELEGRAPHY AT HOME MORSE AND WIRELESS

TEACH YOURSELF

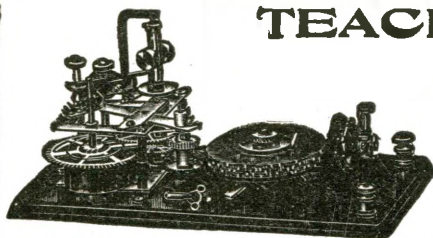

In half the usual time, at trifling cost, with the wonderful Automatic Transmitter, THE OMNIGRAPH, Sends unlimited Morse or Continental messages, at any speed, just as an expert operator would.

Adopted by U. S. Gov't. 4 styles. Catalogue free.

OMNIGRAPH MFG. CO.
26 L. Cortlandt St. New York

- and here it is !

Licensed for use only in apparatus manufactured by the De Forest Radio Tel. & Tel. Co.

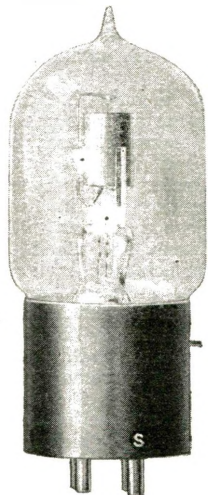

Equipped with the SHAW standard four-prong base. PRICE \$7.50. Order from your dealer.

You have hoped for it. You have looked for it. You have asked for it. And here it is—a transmitting tube for telephone and telegraph C-W transmission, built right up to British and to French Government specifications. Capacity about 12.5 watts, and any number may be used in parallel—four, make telephone conversation possible over 25 miles, telegraph signals over 50 miles.

The plate of this transmitting tube is nickel, a special molybdenum grid is provided and the high vacuum permits operation on plate potentials of five hundred volts without breakdown.

By connecting the grid and plate together, the tube may be used as a rectifier for obtaining from an alternating current supply the high plate potential necessary for the generator tube.

Adopted by the De Forest Radio Tel. & Tel. Co. as the standard transmitting tube in all De Forest sets of less than 1/2 k.w. capacity. Licensed under the De Forest Audion and Fleming patents. Other patents applied for and pending.

Atlantic Radio Supplies Co. 8 Kirk Place, Newark, N. J.
Pacific Radio Supplies Co. 638 Mission St., San Francisco, Cal.

Distributors for Moorhead Laboratories, Inc., Manufacturers of

The A-P Transmitting Tube

MURDOCK

No. 55

THE PRICES ARE
UNUSUALLY LOW

2000 OHM
DOUBLE SET

\$4⁵⁰

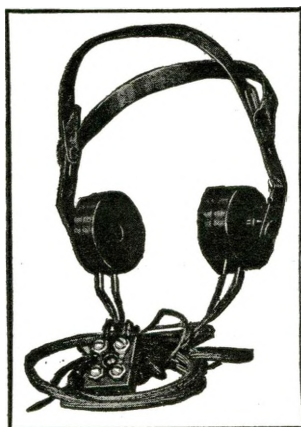

THE QUALITY IS
REMARKABLY HIGH

3000 OHM
DOUBLE SET

\$5⁵⁰

RIGHT IN PRICE AND IN PERFORMANCE

The substantial success earned by these receivers can be attributed to the instant recognition of their remarkable value by thousands of users. If, by chance, YOU are dubious regarding the possibility of securing really good 'phones at such prices, we suggest a trial, with the customary assurance of "satisfaction or money back." Ask your dealer for them.

BULLETIN No. 20 now ready for distribution. Send for your copy.

WM. J. MURDOCK CO.

55 Carter St., Chelsea, 50, Mass.

509 Mission Street, San Francisco, Cal.

CLAPP-EASTHAM APPARATUS

RADION RECEIVING TRANSFORMER

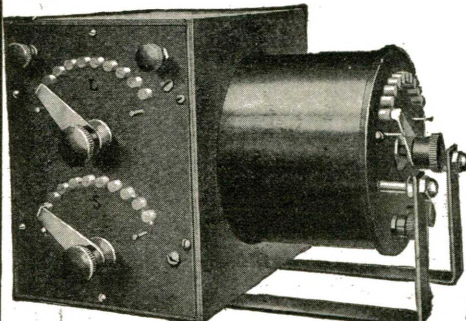

The instrument is designed for those who prefer a tuner having conventional cylindrical coils rather than the rotary type. The disadvantage of most couplers of this type is the large table space necessary to accommodate them. This disadvantage has been eliminated to a large degree in this instrument by the use of banked windings. Both primary and secondary coils are provided with taps, eliminating all sliding contacts. The primary has two 10-point switches, one each for fine and coarse adjustments, while the secondary has one 10-point switch. Bakelite is used throughout for the panels, and the primary is completely enclosed in an oak cabinet. This instrument provides close adjustments with freedom from interference and will respond to wave-lengths up to

3000 meters with an average antenna. The completed tuner measures 6 in. deep by 5 1/4 in. high by 8 in. long.
List No. 12054 Radion Receiving Transfor. \$14.00

BLITZEN RADIOCOUPLER

Variable inductances of this type while commonly used in commercial practice have heretofore been beyond the reach of the experimenter, due to their high cost.

The Blitzen Radiocoupler is offered at a moderate cost, and provides all the advantages found in the more expensive types. The framework is of oak in dull black finish, the stationary frame carrying the secondary of eight turns of edgewise-wound copper strip 10 1/4 inches in diameter. The swinging member carries the primary of five turns of edgewise-wound copper strip 7 1/2 inches inside diameter and both windings are supported by slotted uprights of Bakelite.

The primary is continuously adjustable by means of a projecting handle as shown in the illustration, while helix clips of the usual type are fitted to the secondary.

List No. 252 Blitzen Radiocoupler.....\$22.00

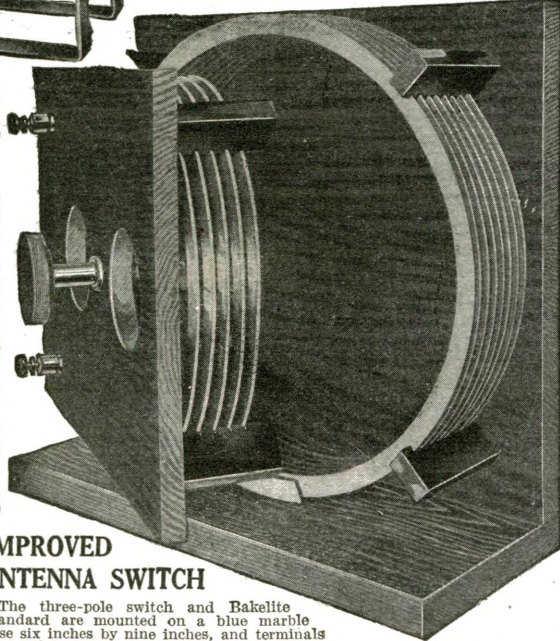

IMPROVED ANTENNA SWITCH

The three-pole switch and Bakelite standard are mounted on a blue marble base six inches by nine inches, and terminals are sufficiently separated to provide protection to sets up to 1 K.W. When thrown to the upper or receiving position, the switch disconnects the antenna from the helix, connecting it to the receiving set and opening the power circuit so that damage to the receiving instruments through accidental pressure of the transmitting key is impossible. When in the down or sending position the antenna is disconnected from the receiving set and connected to the transmitter, the current supply is closed to the transmitter, the receiving set is short-circuited and grounded for protection and the right-hand switch blade closes the circuit to the motor of a rotary spark gap or closes any other circuit desired. Weight, 12 pounds.

List No. 253 Improved Antenna Switch.....\$12.50

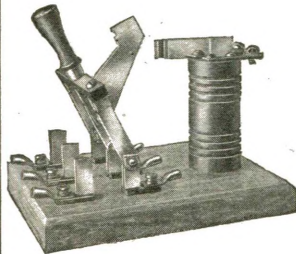

Get a Copy of Our 200 Page Manual of Wireless Telegraphy W12

and Order All of Your RADIO MATERIAL from One Source of Supply and Save Trouble

You cannot get satisfaction from wireless instruments unless they are absolutely perfect. The slightest imperfection in construction destroys their efficiency. We offer for sale wireless apparatus only of the highest quality, guaranteed to be mechanically and electrically perfect.

Our combined Manual and Catalog illustrates and accurately describes the uses of standard radio instruments and should be of great assistance, not only to the amateur but to the professional user and experimenter in selecting proper radio material.

We Make a Charge of 25c. for this Manual, Issuing a Coupon Redeemable on an Order for \$5.00 or More.

It is the Last Word in Wireless Catalogs. Send for a Copy Now. You Cannot Afford to be Without One When You Want to Buy.

MANHATTAN ELECTRICAL SUPPLY COMPANY, Inc.
New York, 17 Park Place
Chicago, 114 So. Wells St.
St. Louis, 1106 Pine St.
San Francisco, 604 Mission St.



Building Machines Accurately

(Continued from page 926)

into the hole and the large end will not go into it. If both ends of the plug will pass thru the hole, it is too large. If neither end will pass thru, it is too small; thus a total variation of only a thousandth of an inch is permitted—half of a thousandth larger or a half of a thousandth smaller, than the exact size.

To speak of a hair's-breadth expresses the ultimate in the average person's conception of minute measurements; but a human hair might be split into ten or twenty parts and the micrometer could measure it—such small measurements are, in fact, employed commercially in our modern machine shops. These instruments are made in Sweden, C. E. Johansson being the maker. These are ordinary looking little blocks of steel, yet they are of various widths, varying from each other by tenths, hundredths, thousandths and ten thousandths of an inch, so that by combining various blocks any desired measurement, to the ten-thousandth part of an inch, can be obtained. In fact these instruments are guaranteed accurate to the one-hundred-thousandth part of an inch.

Let us pause and consider just what 1/100,000 of an inch is. If the human hair could be split into two hundred parts, each of these would be 1/100,000 of an inch in diameter. A silver quarter of a dollar, stood on edge, bears the same relation to the height of New York's tallest skyscraper that the 1/100,000 part of an inch bears to one inch.

But consider further what such accuracy means in a block of steel. It means that one edge must be substantially parallel to the other or the blocks could not give the same measurements at every point. It means that the surface must be absolutely plane or the unevenness in the surface would cause inaccuracies. It means that the surfaces must be perfectly flat so that the blocks can be properly combined to produce dimensions that are a sum of the several blocks in combination.

Accuracy has been secured to such a degree that a combination of the blocks will measure to within a hundred-thousandth of an inch of the sum of the widths of the several blocks. And when the blocks are so combined they will stick together, not by any force of magnetism or atmospheric pressure, but by some unknown force, presumably the same force that holds the molecules together in a single piece of steel. In support of this theory is the fact that the longer the blocks are left together, the tighter they hold, so that the user is advised to separate them at least once each day.

NEW VULCANIZING PROCESS.

Experiments conducted by the Manchester (England) College of Technology have led to the discovery of an important process for vulcanizing which is expected to have far-reaching effects on the rubber manufacturing industry. An official report states that in the new vulcanizing process two gases are used—sulfurated hydrogen and sulfur dioxide—which react on each other to produce water and free sulfur, which vulcanizes the rubber.

The importance of the discovery is said to lie in the fact that it makes cold vulcanizing possible. One claim is that the discovery will make possible the manufacture of one-piece boots without stitching, and that its use will extend to the manufacture of linoleum floorings, artificial leather upholstery and wall paper and probably affect the production of rubber tires.

Detector Amplifier

A complete Detector (without tube) \$10.00

A Single Stage Amplifier " " 13.00

High Amplification at Low Cost

Write for Bulletins

ACME APPARATUS CO.

28 Windsor Street

Cambridge, 39, Mass.

TRANSFORMER AND RADIO ENGINEERS AND MANUFACTURERS

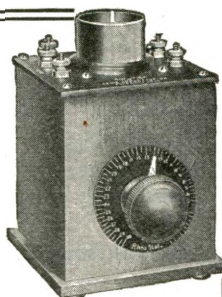

Floating Sunken Ships

(Continued from Page 839)

the submerged ship, serve to force out the water thru the same holes by which it had entered the hull, while the water pressure from outside holds the patches tight to the hole in the ship's side.

The experts in charge of the work proceeded to have the rents closed up in a temporary yet secure fashion, and the S. S. *Royal George* was thus salvaged from her watery grave in the short space of six days. Comprest air had thus served as the genie by which the buoyancy of the vessel was quite restored, and the engineers were able not only actually to float the wreck, but to take the ship out to sea again without dry-docking.

How Cofferd Dams and Submerged Electric Pumps Salvage Ships.

In a number of instances which are on record, something radically new even to salvage engineers has recently been brought out. This scheme consists in building large coffer dams of wood or steel directly over the larger hatchways in the vessel's deck or over other openings, and then proceeding to pump out all of the water embraced within the coffer dam and in the hull of the vessel by means of submerged electric pumps.

It is well known by those familiar with pumps in general, and particularly the large steam pumps generally used in modern salvaging, that this type of pump would raise water to a height of only 28 feet. But the latest electrically driven submergible pump, shown in lower right corner of accompanying illustration, can be lowered to a depth of 80 feet or more, from which depth it will shoot upward a veritable mountain of water in a remarkably short time owing for one thing to its high speed. As many of these electric submergible pump units as deemed necessary may be lowered down into the holds of the sunken ship. One excellent feature this pump possesses for salvaging undertakings, is that the electric current operating the pump motors is under instant control from the surface. Moreover these pumps do not have to be raised if for any reason the salvaging operations have to be discontinued for a day or more, owing to stormy weather, etc., but can be left right in place and the work resumed at the first opportunity.

The great mechanical superiority of this form of salvage pump will at once be evident, as the centrifugal pump secured to the motor sucks in the water to be raised right at the pump, and not thru a length of pipe as in the case of the steam pumps previously used; and once the powerful centrifugal pumps have sucked in this water, they proceed to hurl it toward the surface with tremendous power, from a depth of 80 feet or more.

There are several ways in which this system of coffer dams placed over the hatchways, and used in conjunction with electrical submergible pumps or other paraphernalia, may be successfully applied. One of the first considerations which the student of such affairs would be interested in, is of course, as to how the rents or holes, caused by torpedoes or collision, are to be taken care of; as it is evident in some cases particularly where these rents are large, say 20 by 30 feet or greater, the pumps cannot remove the water as fast as it enters the hole.

There are two principal methods followed in repairing the sunken vessel for this salvage operation: The first is to lower flexible patch blankets made of heavy woven rope, often reinforced with wooden beams

CONNECTICUT RADIO

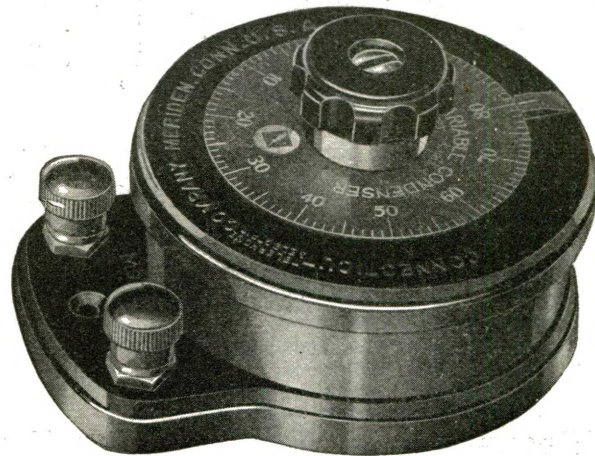

An Amateur Copies POZ with the Connecticut Variable Condenser

An amateur in Southeastern New York says in a recent letter:

"I have purchased four of your Connecticut Variable Condensers and it is possible to get better results with them than with the multiplate type of Variable.

"I spent several weeks trying to get signals from the European stations. At first I was unsuccessful. I bought one Connecticut condenser for trial. It tuned the radio signals so sharply (and better than other variables) that I bought three others. Much to my expectation they did so remarkably well and I was soon copying POZ and other European stations without much difficulty.

"Hereafter I will use Connecticut Variables in all my circuit as they are actually cheaper in the long run and are far more efficient for radio receiving sets."

Your set will be a better one with the Connecticut Condenser. The instrument is set at .001 mfd., adjustable either higher or lower.

There's a booklet with full information waiting for you. Send for your copy

CONNECTICUT TELEPHONE COMPANY
Meriden & ELECTRIC Connecticut

Paragon RA-TEN



Amplifying Short Wave Receiver

Licensed Under Armstrong and Marconi Patents

You'll Hear Stations You Never Heard Before With this NEW Paragon!

The original RA-Six was the acknowledged superior of any other set on the market. This NEW triumph of Adams Morgan Co. is as far ahead of the RA-Six as that was ahead of all others.

- Here are a few outstanding features.
- Wave length 160 to 1000 meters.
 - Amplification 100 times.
 - No dead end losses whatever.
 - Vernier attachments on all controls.

The Paragon RA-Ten covers amateur, commercial, and Navy wave-lengths. Advanced engineering design, combined with superior insulation and accurate controls, enables you to hear the weak station plainly and with proper selectivity, **that one station only.** All amplification is obtained without change of spark tone. Objectionable effect of change of note is entirely eliminated. Coupling has scale of 180°. The cabinet is of quartered oak; overall size $20\frac{5}{8} \times 8 \times 7\frac{1}{2}$ ". Fitted with genuine Bakelite panel, knobs and dials. White filled engravings. Truly an instrument to be proud of. **Every set sealed and guaranteed for two years.**

PRICE EIGHTY-FIVE DOLLARS COMPLETE

Send for our special bulletin on the Paragon RA-Ten interesting and complete. Drop post card today

Our word of honor to you is our guarantee. Let us prove it.

CONTINENTAL RADIO AND ELECTRIC CORP.

Sole Distributors of the New Paragon RA-TEN

J. DI BLASI, Secretary J. STANTLEY, Treasurer
DEPT. A.1 6 WARREN STREET NEW YORK

Some More of Our Radio Mail Order Specialties

VARIOMETERS

As illustrated \$4.50
Others at \$6.00, \$6.50, \$7.00

REGENERATIVE SETS

- Grebe \$65.00
- Signal \$37.50
- Mignon \$60.00

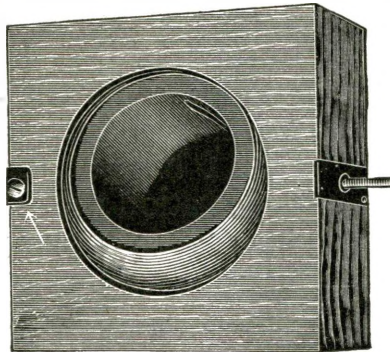

All Instruments sold by us are manufactured by the most reliable Radio firms known. And our very complete stock gives us the opportunity of prompt service at reasonable prices.

Our new and most complete catalog will be ready for distribution shortly. Those having already sent 10c for it, will receive the new issue in a few days.

AMERICAN ELECTRO TECHNICAL APPLIANCE CO.
Dept. E. S.—235 Fulton Street New York

Dependable Radio Apparatus

A new Tuner and a new Short Wave Set have joined the **DEPENDABLE FAMILY**

Catalogue Mailed for 10 Cents in Stamps

DORON BROTHERS ELECTRICAL COMPANY
Hamilton, Ohio

and steel plates or strips, into position against the side of the boat and maneuvered so as to cover the rent as tightly as possible by the aid of divers; while the second principal idea in the preliminary operation, and which has been successfully carried out in some instances, is to have divers descend down into the vessel and erect temporary bulkhead walls, cutting off the damaged sections of the hull, so that the parts to be eventually drained by the submerged pumps as afore described will be made as water-tight as possible.

Unless the vessel has been very severely damaged, and holes torn into her along the greater part of its length, the second procedure of cutting off the damaged section of the hull by means of bulkhead walls is usually successful; and sometimes a combination of the two methods described above is feasible.

It is necessary of course that divers supervise the placing of the bottom of the coffer dam over the hatchways on the vessel's deck, or over other openings, in order to see that they are correctly placed and also made as water-tight as possible.

The electrical energy for operating the submergible pump is supplied from a dynamo driven by a steam or gasoline engine on board the salvage vessel. When all is ready, the electric power is switched on, and the pumps start emptying the water thru the pipes attached to them in the manner shown in one of the illustrations herewith.

As the water is pumped out, the vessel slowly resumes its original buoyancy and finally after a few days pumping—the time required depending upon the size of the vessel—the deck and gradually the upper part of the hull rises above the surface of the water. After the vessel has been raised, it can then be towed to the nearest dry-dock in order to have its rents or holes properly repaired.

Raising Ships by pontoons and Tides

The third method of raising sunken ships illustrated herewith, is that involving the aid of Mother Nature and large pontoons filled with air and possessing great buoyancy and lifting power. This method has been described sometime ago (in this journal), and the technique followed in this method is ingenious indeed. Simply explained, it involves the floating of a large number of steel pontoons to the position where the sunken craft lies, and to proceed with the aid of divers to place substantial ropes or steel cable slings around the hull of the vessel, which are afterward made fast to the pontoons.

It should be mentioned, in answer to the readers' anticipated question, that a new form of tackle or clamp has been developed for securing such cables to the pontoons in a flexible manner, so that a sudden rise or fall of the pontoons and other members, due to high seas, will not cause the cables to snap. The third illustration, which is shown in four stages, shows the procedure of raising vessels with the aid of the tide very clearly. The successive stages progress from left to right.

The tidal rise and fall, of course, is greatly exaggerated in this picture for the sake of illustration.

When the tide has reached its lowest point each day, the pontoon cables are tightened up, and then as the tide rises the vessel is raised a considerable distance or height, equivalent to the tidal rise. The vessel is then towed as far as possible until it strikes bottom again, and the salvaging crew then wait until the tide falls to its minimum point at this new location.

The pontoon cables are again tightened up and when the tide rises the vessel is raised again a certain number of feet. The pontoons and other submergible apparatus are then towed still further into shallow water and eventually the vessel is raised to the surface and is then ready to be dry-docked for repairs.

NEW INTERNATIONAL RADIO TELEGRAPH CO. STATION

The International Radio Telegraph Company announces that it opened its coast radio station at Siasconset, Nantucket Island, Mass. Radio call: WSC, on October 13th.

This island has long been the location of commercial and naval stations and because of its particularly advantageous location will undoubtedly be very generally used by incoming European ships in getting off their traffic on long waves and at long range. The station tax is twelve cents per word.

The station is now equipt to receive long waves, damped or undamped, with Heterodyne reception and for the present will utilize spark transmitters, but general enlargements are now contemplated.

WESTINGHOUSE ENTERS THE RADIO FIELD

One of the important recent developments in electrical industry is the entrance of the Westinghouse Electric & Manufacturing Company into the wireless field. Though prior to the war this company was not commercially interested in wireless, it had devoted a great deal of attention to radio phenomena, and during the war it not only carried out extensive researches for the Government, but also manufactured a large amount of apparatus for military use.

The company has exclusive manufacturing and selling rights under the Fessenden patents for the Heterodyne method of reception, which is universally acknowledged to be among the best for undamped waves; and it also possesses licenses under many other important patents including the Poulsen arc converter system.

Your Duo-Lateral Wound Coils Are Ready

JUST a word of explanation: Our first advertisement caused such an upheaval in radio circles that we were swamped with inquiries. Indeed, one large manufacturer of radio apparatus immediately placed his contract with us, taking over our entire production. As a result we were obliged to turn down orders.

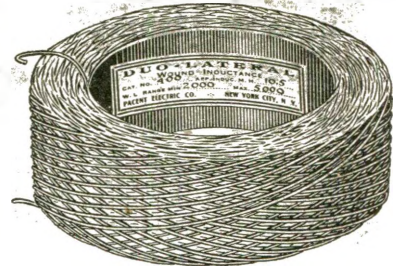

THAT was up till a short while ago. Now we have succeeded in doubling our productive capacity, and Duo-Lateral Coils are available to everyone in the radio field. We can make prompt shipments from stock. *Your DUO-LATERAL COILS are ready to be shipped the moment your order is received.*

REMEMBER, Duo-Lateral Coils are recognized for:

- | | |
|-------------------------------------|-------------------------------------|
| 1. Lower natural period. | 4. Lower direct current resistance. |
| 2. Lower high frequency resistance. | 5. Higher self-inductance. |
| 3. Very low distributed capacity. | 6. Mechanically stronger. |

Bulletin P-1EX, containing valuable engineering data, constants and prices of numerous sizes of Duo-Lateral Coils, covering practically every wave-length used, is yours for the asking.

**TO DEALERS: OUR DISCOUNTS ARE GENEROUS
PACENT ELECTRIC COMPANY, Inc.**

Representing: A. H. Grebe & Co., Dubilier Condenser Co., Electrical Products Mfg. Co., Richter-Schottler Co., The Magnavox Company, The Rawson Electrical Instruments Co. and others.
150 Nassau Street Telephone Beekman 5810 New York City

GREAT RESULTS—

"I have used your tuners, both for short and long waves, and they have always given me entire satisfaction." H. D. Titus, 24 Grove St., Auburn, N. Y. Send 2-cent stamp for Bulletin 111, showing new short and long wave tuners.

Colby's Telegraph School, Auburn, N. Y.

Five-Dial Omnigraphs Bought

at highest prices. Write for prices, stating what you have and how long it has been used. E.L.D., 1312 Belmont St. N.W., Washington, D.C.



Christmas Suggestions for the Radio Amateur



**Type P-200
Two-Step Amplifier**

The newest development in Amplifier design, combining compactness and extreme efficiency in operation. Amplifies the power about 16 times. Panel quickly removable; all parts accessible. Cabinet size 12½ x 9¾ x 7¾. Price (without tubes but including "B" battery) Each \$70.50

PUT DeForest Radio Apparatus on your Christmas list. Get that new apparatus you need as a present. Here are three instruments of typical DeForest high quality which will make your station more modern and greatly increase its operating efficiency.

Our Catalogue "D" illustrates and describes a lot more apparatus you'll be glad to know about. Send 10 cents in stamps and get your copy now, in time to make your selection before Christmas.

DE FOREST RADIO TEL. & TEL. CO.

Inventors and Manufacturers of High Grade Radio Apparatus
1401 Sedgwick Ave., New York City

LEE DE FOREST, Inc.
Western Distributors
451 Third St. San Francisco, Cal.

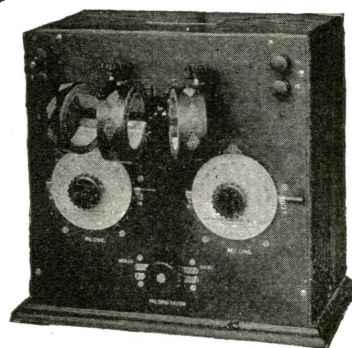

**Type T-200
Multi-Wave Tuner**

Responds to any wave length; 150 to 25,000 meters. Contains triple adjustable coil mountings; Vernier primary and secondary tuning condensers; primary condenser switch; all mounted on engraved Bakelite panel and in handsome cabinet, size 13 x 18 x 12¾. Price (without coils) \$85.00

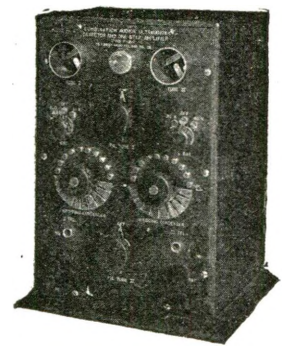

**Type P-300 Combination
Audion — UltraAudion and
One-Step Amplifier**

Specially designed to fill a real need for an instrument of this kind in the average amateur station. When used in connection with the T-200 Tuner shown here, it completes a receiver of unequalled efficiency. Cabinet size 12½ x 8¾ x 4¾. Price (without tubes) . \$75.00



For Perfect Signals and Solid Comfort, Wear Brandes Matched Tone Receivers

WE were not satisfied when we accomplished the mechanical perfection of our receivers to such a high degree for we realized, and every professional knows, that lightness and comfort are almost as necessary as the perfectly matched tone for which Brandes Receivers are famous.

We have now equipped our receivers with an improved head band made to fit any size head and instantaneously adjustable. Checknuts hold the adjustment. The new head band is more durable and lighter in weight. It is made of Galvanized Piano Wire, covered with strongly woven Khaki. There are no metal parts which come in contact with the wearer's head, and the head band cannot catch the hair even when adjustments are made on the head. Other metal parts are nickel plated brass, making the head band absolutely rust proof. Our new head band is the strongest and lightest of its kind on the market.

Our receivers are now equipped with new style conducting cords which indicate the polarity of the receivers. This eliminates any danger of demagnetizing the receivers when used in connection with Vacuum Valve Detectors.



"Superior" 2,000 Ohms, weight 14 ozs. complete with head band and polarity indicating cord. Price \$8.00.

Give yourself a Christmas present. Order any pair of our receivers, try them for 10 days in comparison with the phones you have now. If they aren't better receivers for clearness, sensitiveness, distance and comfort than what you are using, return them to us, and back comes your money immediately and without question.

Send 5c for catalogue E

C. BRANDES, Inc.
Room 814 32 Union Square
NEW YORK CITY

Wireless Receiver Specialists

Transmitting Photographs by Radio

By P. H. BOUCHERON
(Continued from page 883)

THE MARTIN METHOD.

In recent years several investigators have been at work developing systems of radio photography. Prominent among these have been Messrs. De Bernochi, Knudsen, Korn and Martin. To attempt to describe the histories and effectiveness of these systems is, of course, impossible here. For that reason we shall confine ourselves briefly to the method and manner of operation of one of the more modern and recent developments. We have in mind that of M. J. Martin of England, who, incidentally, has prepared some excellent data on the result of his efforts.* As this investigator freely admits, there is considerable room for the improvement of radio photographic systems, and at the present time there exists no entirely satisfactory method; the art being still in the experimental stage. The experiments of Professor Korn of Berlin, however, are prophetic of what may be expected in the future. This scientist has succeeded in sending photographs between Berlin and Paris—a distance of more than 700 miles!

Concerning the system of radio photography employed by Martin, which he has named the "Telephotograph," the following advantages are claimed:

- A greatly improved method of transmitting and receiving over other systems.
- A simple method has been devised for regulating the speed of the driving motors and maintaining isochronism with a limit of error less than 1 in 800.
- An improved arrangement for synchronizing the two machines whereby transmission and reception begin simultaneously.
- Only one complete machine is used at each station.

* Wireless Transmission of Photographs, Wireless Press, London

TRANSMISSION.

In Fig. 1 is shown a schematic diagram of the apparatus and method of connection for a complete station; that is, transmitting and receiving combined. In the present case the problem is to prepare a photograph so that the light and dark shadings composing its make-up will be made to act upon a stylus at a more or less degree of pressure and length, the stylus, in turn, being made to operate a relay connected to a regular spark transmission system. These constantly broken up signals are in a like manner recorded at the receiving station in such a way that they will cause light and dark shadings to be impressed upon a sensitive photographic plate in the identical order of their original transmission.

In order to accomplish the above, the original photograph is first copied by means of a copying camera which, however, is furnished with a "cross" screen placed between the photographic plate and the lens.* The result is that the finished negative is composed of cross-sectioned lines. From this cross-section-lined negative a print is made upon a specially prepared sheet of metal. The result is that of an image composed of numerous cross-sections of insulating material corresponding to the characteristics of the illustration. Between each cross-section there are likewise spaces of conducting material. This prepared metallic print is then placed upon the transmitter drum, shown in the illustration, in such a manner that the stylus is progressively made

* See article "How Color Magazine Covers Are Made" in the November issue.

Do You Know An ACE

that the ACE Type B 2-step Amplifier will give you 450 times amplification of signal? Price \$20.00, ready to wire. Diagram furnished.

We manufacture and handle complete lines of Radio instruments and accessories.

Write for catalog.

"You may pay more—but you can't buy better."

THE PRECISION EQUIPMENT CO.

Dept. E, 2437 Gilbert Avenue
Cincinnati, Ohio

The Corwin Dials



are now used exclusively by the Radio Distributing Co. and all manufacturers whose apparatus is of a superior nature.

If you want indicating dials for superior performance, buy the Corwin Dials. Black composition, white filled engraving, beveled edge.

3" Dial \$0.75. With Knob . . . \$1.30 Postpaid
3 7/8" Dial 1.00. With Knob . . . 1.70 Postpaid

We are distributors of the better class of radio apparatus and offer a superior service on products manufactured by Acme, A. R. Co., Murdock, Clapp Eastham, Moorhead, etc.

Send 10c. for latest catalog describing above dial and all Radio Apparatus.

A. H. CORWIN & CO.
4 W. Park St., Dept. E, 1, Newark, N. J.

Arnold Loose Couplers

Combination Loose Coupler Parts and accessories.

Send 3c stamp for literature which is sure to interest you.

J. F. ARNOLD

2082 Lexington Av. N.Y.
Established 1910



SENT TO YOU FREE TO WEAR 10 DAYS

Just send your name for a beautiful Rosebrite ring. Wear this wonderful new sparkling stone ten days at our risk. All the dazzling fire and brilliance of a genuine diamond. Mounted in solid gold ring, men's or women's style.

Send No Money! Simply write today, stating style of paper just long enough to meet over second joint of ring finger. Do not send a penny. When ring arrives deposit only \$4.75 with postman. Wear it 10 days. We guarantee to refund your deposit if you can tell this marvelous gem from a genuine diamond. If you keep it send \$3.00 a month for four months. Write today before this amazing, cut-price offer is withdrawn.

30 North Dearborn Street
Rosebrite Diamond Co., Dept. 5812 CHICAGO, ILL.

EARN MORE MONEY
Learn Sign Painting - Card Writing - Auto Painting
Decorating - Paper hanging - Graining - Marbling
Short terms - low cost - Catalog free
Chicago Painting School
146 W. AUSTIN AVE. Near Wells Street.



FREE \$20 TENOR BANJO

Ukulele, Hawaiian Guitar, Violin, Mandolin, Guitar, Cornet or Banjo
 Wonderful new system of teaching note music by mail. To first pupils in each locality, we give a \$20 superb Violin, Mandolin, Ukulele, Guitar, Hawaiian Guitar, Cornet, Tenor Banjo or Banjo absolutely free. Very small charge for lessons only. We guarantee success or no charge. Complete outfit free. Write now. No obligation.
SLINGERLAND SCHOOL OF MUSIC, Inc. Dept. 41 - CHICAGO, ILL.

LITTLE GIANT DRILL PRESS
 Just the thing for small shop and experimental work. Mechanically right and well made. Size 0 to 1/2" drill. Weight 22 lbs. Price \$15.00.
 Send for circular
SYPPER MFG. CO.
 Dept. "C" Toledo, Ohio

SAVE 25% to 60%
 on slightly used **GRAFLEX-KODAKS**
 Cameras and Lenses of every description. Equal to new. Save money. Write now for **Free Bargain Book and Catalog** listing hundreds of money-saving bargains in slightly used and new cameras and supplies. All goods sold on 10 days' Free Trial. Money back if not satisfied. You take no chance dealing with us. We have been in the photographic business over 16 years. Write now.
CENTRAL CAMERA CO., Dept. 112 124 S. Wabash, Chicago

EASIEST SHORTHAND
 Learn in 5 evenings home study then acquire speed with K. I. Shorthand. Amazingly simple, easy. Approved by experts. Write dictation, messages, etc., rapidly as spoken, after brief pleasant practice. Favorite method for personal use; make notes at lectures, meetings; keep confidential diary. Big help to any profession or business; aid in your career. Used in Army, Navy, courts, commercial schools, by public and stenographers, teachers. Slight cost. K. I. Shorthand - for busy people, including YOU. Proof Lessons. Guarantee and Refund. Complete prepaid. Address: **KING INSTITUTE, EL-300 - Station F, NEW YORK CITY**

STUDENTS' ART MAGAZINE
 Publishes cash assignments, lessons and articles on Cartooning, Designing, Illustrating, Lettering and Chalk-Talking. Criticizes amateurs' work. Full of information for artists and art students. Satisfactory or money refunded.
 20c a copy, \$1 for 6.
 Send \$1 NOW. Thrift Stamps Taken
G. H. LOCKWOOD, Editor, Dept. 619, Kalamazoo, Mich.
 A NEW AND EASY WAY TO PAINT

SIGNS AND SHOW CARDS
 OUR PATTERNS DO THE WORK
 No experience required. Any one can paint all kinds of signs, banners, cards, etc., on any surface with our new and easy system of lettering. Complete outfit containing six alphabets of letters, assorted styles and sizes from two to twelve inches high, also three sets of figures, etc., not printed but life size patterns cut out of durable tin board which can be used over and over again for years, also brushes, colors and book of instructions, **PREPAID \$10.00**. Satisfaction guaranteed.
ACME SALES CO., Empire Bldg., Dept. S., Denver, Colo.

The Universal Triangles
 A 7" direct ruling Protractor with Vernier reading and secure adjustment. The 30x60 and the 45x90 transparent triangles—all in one.
 The most practical and thoroughly satisfactory tool for draftsmen.
 You cannot afford to be without it. Ask for my **SPECIAL OFFER** to one draftsman in any school or shop.
EDWIN Z. LESH, Dayton, Ohio

Learn Watch Repairing
 Be a watchmaker—you can learn this profitable trade by correspondence in a few weeks in your own home by the DeSelm's Chart System. After you complete the course you will know a watch from A to Z. You will know just what the matter is and how to repair one. When you graduate you will be a practical watchmaker and repairer and competent to fill any position. Positions for our graduates.
 Ask for our Free Book. It explains our system and terms.
THE DESELMS WATCH SCHOOL
 720 Perry St., ATTICA, IND.

TELEGRAPHY
 (Both Morse and Wireless) and **RAILWAY ACCOUNTING** taught thoroughly and quickly. Big salaries now paid. Great opportunities for advancement. Oldest and largest school established 45 years. Endorsed by Telegraph, Railway, Radio, and Government officials. Expenses low—opportunities to earn large portion. Catalog free.
ODDGE'S INSTITUTE A Street, Valparaiso, Ind.

STAMPS
 50 all diff. British Guiana, Cuba, China, India, Jamaica, Japan, Portugal, Venezuela, etc., only 10c; 100 all diff. 15c; 1000 all diff. fine collection in itself, \$5.00; 100 diff. U. S. 30c; 100 hinges, 10c. Agents wanted, 50% commission. List free. **BUY STAMPS.**
C. B. DOVER LONGMONT, COLO.

to trace a path from one end of the print to the other. One end of the radio transmitter relay is connected to the stylus, while the other end is connected to the shaft attached to the metal drum. In this manner the various shadings of the print cause a short, long or no signal to be transmitted by means of the regular radio transmitter.

In order to prevent possible sparking at the point of contact between the stylus and the specially prepared print, a condenser of 1 mfd. is placed across the circuit.

When the complete line print wrapt around the drum of the machine has past under the stylus the end of the shaft reaches the spring of the circuit-breaker, thereby breaking the clutch circuit and allowing the motor to run free.

RECEPTION

At the receiving end a regular radio receiver is employed, where the rectified current is made to pass thru a Brown telephone relay, from which it is directed to a special telephone receiver of extremely sensitive construction. To the diaphragm of this receiver is arranged a pivoted rod, on the end of which is the shutter placed between the two lenses, the opening and the closing of the shutter is, therefore, dependent upon the minute currents received by the sensitive receiver and where the following optical action takes place. By means of the Nernst Lamp and the condensing and focusing lenses a magnified shadow of the shutter is thrown upon the screen, having its small opening or "window" bored thru the center, and a certain amount of light from the lamp reaches the photographic film wrapt around the drum of the machine thru the medium of the above small hole. When, however, signals are transmitted, the magnified current from the telephone relay energizes the coil of the special telephone, thereby attracting the diaphragm and causing the above-mentioned movement of the pivoted rod. It is by means of this optical arrangement that a magnified movement, as well as a magnified image of the shutter, is thrown upon the screen in such a manner that this shadow of the shutter will cover the hole in the screen and prevent any light from reaching the film. Thus, when the stylus of the transmitter at the distant station traces over a conducting strip on the metal print, no light reaches the film of the receiving station, but when it is tracing over an insulating strip the shadow of the shutter on the screen rises and the light from the Nernst Lamp reaches the film. By this method a positive picture is received, which is of great advantage when photographs are required for immediate reproduction.

Static, of course, will make itself visible at the received station by irregular transparent marks on the film after development. These, however, can easily be eliminated by means of retouching.

The aluminum rod, as well as the optical parts mentioned here, are enclosed in a light-proof box in order to protect the film from outside light. In fact, the entire photographic end of the receiver must be enclosed within a dark room and observed only by means of a regular photographer's ruby lamp.

Some interesting devices connected with this system are the friction brake, which is designed to reduce the speed of the motor until the isochronizer indicates that the correct speed has been obtained. The isochronizer, on the other hand, is a device for insuring the correct speed regulation of the driving motors. The contact-breaker operates as soon as the transmitter sends out the first signal, whereupon the magnified current from the telephone relay actuates the polarized relay, which in turn completes the circuit.

The accurate performance of this system depends primarily upon the synchronizing

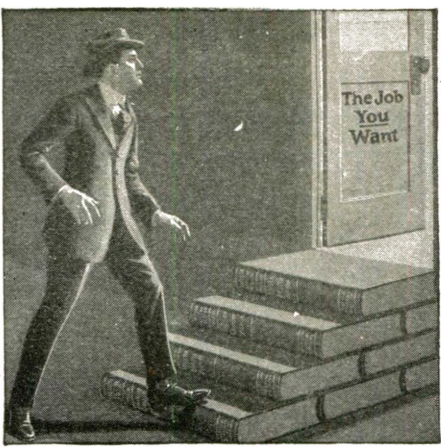

Step Up to a Better Job!

That better job and the bigger pay that goes with it—the job you want—is within your reach. It's only a step to the really big jobs from where you are. That step is simply "knowing how." The practical books for self-training described below will give you that "know how." They are the steps by which you can reach the job you want.

Some of the best authorities in the world wrote these books in plain, everyday language. Anyone who can read and write English can understand them. Thousands of pictures, diagrams, etc., make difficult points as plain as day. Over 1,000,000 volumes have been sold.

Pay-Raising Books at Greatly Reduced Prices

- Automobile Engineering, 6 volumes, 2600 pages, 2000 pictures. Was \$45.00.....Now \$29.80
- Carpentry and Contracting, 5 volumes, 2138 pages, 1000 pictures. Was \$37.50.....Now \$24.80
- Civil Engineering, 9 volumes, 3900 pages, 3000 pictures. Was \$67.50.....Now \$39.80
- Accountancy and Business Management, 7 volumes, 2700 pages, 1000 pictures. Was \$52.50.....Now \$29.80
- Fire Prevention and Insurance, 4 volumes, 1500 pages, 600 pictures. Was \$30.00.....Now \$19.80
- Electrical Engineering, 8 volumes, 4100 pages, 3300 pictures. Was \$60.00.....Now \$34.80
- Machine Shop Practice, 6 volumes, 2300 pages, 2500 pictures. Was \$45.00.....Now \$29.80
- Steam and Gas Engineering, 7 volumes, 3300 pages, 2500 pictures. Was \$52.50.....Now \$29.80
- Law and Practice (with reading course), 13 volumes, 6000 pages, illustrated. Was \$97.50 Now \$49.80
- Telephony and Telegraphy, 4 volumes, 1728 pages, 2000 pictures. Was \$30.00.....Now \$19.80
- Sanitation, Heating and Ventilation, 4 volumes, 1454 pages, 1400 pictures. Was \$30.00.....Now \$18.80
- Practical Accounting, 4 volumes, 1840 pages, 800 pictures, etc. Was \$20.00.....Now \$14.80
- Drawing, 4 volumes, 1578 pages, 1000 pictures, blueprints, etc. Was \$30.00.....Now \$19.80

Send No Money Shipped for 7 Days' Trial

Write the name of the books you want on the coupon and mail it today. We will send the books at once, express collect, and you can use them just as if they were your own for a whole week. If you decide you don't want to keep them, send them back at our expense.

75c a Week
 If you like the books, as thousands of other men have after examination, just send us \$2.80. You can send the balance of the special reduced price the same way—\$3.00 each month, 75 cents a week.
 Step up to a better job with bigger pay. MAIL THE COUPON NOW. It's your first step.
AMERICAN TECHNICAL SOCIETY
 Chicago, U. S. A.

American Technical Society, Dept. X-259, Chicago, U.S.A.

Please send me set of

.....

for 7 DAYS' examination, shipping charges collect. I will examine the books thoroughly and, if satisfied, will send \$2.80 within 7 days and \$3.00 each month until I have paid the special price of \$..... If I decide not to keep the books I will return them at your expense within one week.

Name.....

Address.....

Reference.....

(Please fill out all lines.)

**GET A
COMMERCIAL
OPERATORS
LICENSE**

We train you in the shortest possible time for a first grade license

**MODERN EQUIPMENT
BEST INSTRUCTORS
SHORT COURSE**

New Federal Arc Set recently installed

**EAST SIDE Y.M.C.A.
RADIO SCHOOL**
152 East 86th Street, New York City



Packard

Owners of the 1-2 K. W. 13,200 high voltage type report distances of 450 to 500 miles. This cannot be equalled, using any other make of wireless transformer for amateurs. Adjustable power, large overload capacity and safety spark gap are but a few of the many good points.

With the Packard you will be leader of all operators in your district.

For this is the most powerful transformer that can be used for amateur purposes under Government regulations.

Write for our illustrated bulletin.
Warren, Ohio

Wireless Transformers

Pure Copper Aerial Wire

14 GAUGE—2 ft. for One Cent
12 GAUGE—80c for 100 ft. Roll

Postage Must Accompany Order



Send 15c for our big illustrated Catalogue showing scores of bargains in radio apparatus. This may be deducted from your first order of \$1.50 or over. High printing costs make free distribution impossible.

ELECTRICAL SPECIALTY COMPANY
Dept. E, 48-50 S. Front St., Columbus, Ohio
Dept. E, 20 N. 9th St., Philadelphia, Pa.



DEAFNESS IS MISERY

I know because I was Deaf and had Head Noises for over 30 years. My invisible Antiseptic Ear Drums restore my hearing and stopped Head Noises, and will do it for you. They are Tiny Mechanisms. Cannot be seen when worn. Effective when Deafness is caused by Catarrh or by Perforated, Partially or Wholly Destroyed Natural Drums. Easy to put in, easy to take out. Are "Unseen Comforts." Inexpensive. Write for Booklet and my sworn statement of how I recovered my hearing.

A. O. LEONARD
Suite 369, 70 5th Avenue -- New York City

SEX BOOKS

For Teachers, Students, Physicians, Nurses, Jurists, Lawyers, Social Workers, Clergymen, Priests, Professional and Advanced Adult Readers.

Send for List
THE MODERN BOOK SOCIETY
6 Hanson Place, Desk 55, Brooklyn, N. Y. City
"Books for Intelligent People"

and the isochronizing of the two stations and these are the most difficult problems encountered. As a matter of fact, both stations must be almost perfectly synchronized during operation, if an accurate photograph is to be produced.

Another important factor is the correct starting of the picture upon the receiving drum. Not only must the two machines revolve in perfect accord, but they must begin to transmit and record at exactly the same spot on the cylinders, so that the component parts of the received image shall occupy the same position on the photographic paper or film as they do on the metal print at the transmitter end. Otherwise, if the receiving cylinder is permitted to revolve slightly before reproduction has started, the final print would be entirely misplaced; the bottom part of the picture appearing at the top, or *vice versa*, as the case may be, thus ruining the resultant illustration.

The practical transmission and reception of illustrations thru the medium of *radio waves* is by no means a simple matter and requires the use of most sensitive receiving instruments as well as exacting patience in adjusting sender and receiver. However, it will not be many years before our transoceanic radio stations will devote part of their operating hours to the reception and transmission of photographs to accompany the text of the news items previously sent.

STATEMENT OF THE OWNERSHIP, MANAGEMENT, CIRCULATION, etc., required by the Act of Congress of August 24, 1912; of ELECTRICAL EXPERIMENTER, published monthly, at New York, N. Y., for October 1, 1920.

State of New York, County of New York, ss.

Before me, a notary public in and for the State and county aforesaid, personally appeared Hugo Gernsback, who, having been duly sworn according to law, deposes and says that he is the Editor of the ELECTRICAL EXPERIMENTER and that the following is, to the best of his knowledge and belief, a true statement of the ownership, management (and if a daily paper, the circulation), etc., of the aforesaid publication for the date shown in the above caption, required by the Act of August 24, 1912, embodied in section 443, Postal Laws and Regulations, printed on the reverse of this form, to wit:

1. That the names and addresses of the publisher, editor, managing editor, and business managers are: Publisher, Experimenter Publishing Co., 233 Fulton St., New York City; Editor, Hugo Gernsback, 233 Fulton St., New York City; Managing Editor, Harry Winfield Secor, 233 Fulton St., New York City; Business Manager, R. W. DeMott, 233 Fulton St., New York City.
2. That the owners are: (Give names and addresses of individual owners, or, if a corporation, give its name and the names and addresses of stockholders owning or holding 1 per cent or more of the total amount of stock.) Experimenter Publishing Co., 233 Fulton St., New York City; Hugo Gernsback, 233 Fulton St., New York City; Sidney Gernsback, 233 Fulton St., New York City; Harry Winfield Secor, 233 Fulton St., New York City.
3. That the known bondholders, mortgagees, and other security holders owning or holding 1 per cent or more of total amount of bonds, mortgages, or other securities are: (If there are none, so state.) None.
4. That the two paragraphs next above, give the names of the owners, stockholders, and security holders, if any, contain not only the list of stockholders and security holders as they appear upon the books of the company but also, in cases where the stockholder or security holder appears upon the books of the company as trustee or in any other fiduciary relation, the name of the person or corporation for whom such trustee is acting, is given; also that the said two paragraphs contain statements embracing affiant's full knowledge and belief as to the circumstances and conditions under which stockholders and security holders who do not appear upon the books of the company as trustees, hold stock and securities in a capacity other than that of a bona fide owner; and this affiant has no reason to believe that any other person, association, or corporation has any interest direct or indirect in the said stock, bonds, or other securities than as so stated by him.

H. GERNSBACK.

Sworn to and subscribed before me this 13th day of October, 1920.

Beatrice K. Owen, Notary Public, New York County, New York; New York County No. 57; New York Register No. 1129.- (My commission expires March 30, 1921.) (Seal.)

**SKINDERVIKEN
TRANSMITTER BUTTON**



This famous button made in several styles for experimenters and wireless men. Super-sensitive style for detectophone work.

Sends piano, violin and victrola music thruout the house. Common battery style for wireless telephone and amplifier use. Capable of passing a greater amperage than most transmitters. Price with complete instructions for use \$1.00.

Mechanical Stethoscope



Price \$5.00

Detects knock and trouble in all running machinery. Use it to test the motor of your automobile. Garages and Dealers stock up for Christmas.

Every automobile owner should have one. Send for list of experimental equipment, receivers, ringers, etc.

GENERAL SOUND TRANSMISSION CORPORATION Room 507
2 Rector Street
New York

**MEMORIZE
CONTINENTAL CODE
ALMOST INSTANTLY**

Our method is THE short cut.
Successfully used by thousands.

"What They Say About It" Free. Master the Code and you overcome the only obstacle to quick success.

Chart and Instructions, 50 Cents
C. K. DODGE
Box 300 Mamaroneck, N. Y.

[RADIO] Mail Order SERVICE

A complete stock and prompt deliveries is a combination you can't beat. Any radio instrument mailed postpaid anywhere. Try our service. Send 10 cents for catalog.

KELLY & PHILLIPS
312 Flatbush Ave., Brooklyn, N. Y.

RADIO CLUB PINS

Special folder of designs and prices in addition to regular School pin catalog free on request. Be sure to see these new numbers which will put new life in your club.

METAL ARTS CO.
Dept. 12 Rochester, N. Y.



LEARN WIRELESS

At the OLDEST, LARGEST and BEST EQUIPPED school of its kind in New England. Thousands of satisfied graduates all over the world. Splendid opportunities in the Merchant Marine. Day and Evening classes. Start any Monday. Illustrated Prospectus for the asking.

EASTERN RADIO INSTITUTE
899E Boylston St. Boston, Mass.

**NEW 1920
RED HEAD PHONES**



\$12.50

We announce the new model of the famous Red Head Radio Receivers, greatly improved, 3200 ohms, \$12.50 the pair.

THE NEWMAN-STERN CO.
Dept. E. E. Cleveland, Ohio
Distributors for DeForest, Murdock, Signal, Bunnell and other famous lines.

WIRELESS TELEGRAPHY

Make your own "Wireless," also Dynamos, Batteries, Motors, Telegraph, Telephone, Lights, Bells, Alarms, Coils, Current Reverser, Electric Engines, etc. Book with 75 illustrations; by experts so anyone can understand it. With Catalog, All 10c, 3 for 25c pp

J. C. DORN. 705 S. DEARBORN STREET
Dept. 22. CHICAGO, ILL.

**"They WORK
while you sleep"**



**Best Laxative for Men,
Women and Children.
10, 25, 50c—drugstores.**

STOMACH TROUBLE

Regulate your digestion so you can eat favorite foods without fear of

- Indigestion
- Flatulence
- Gases
- Acidity
- Palpitation

A few tablets of Pape's Diapepsin correct acidity, thus regulating the stomach and giving almost instant relief. Large 60c case—drugstores.

PAPE'S DIAPEPSIN

Don't Wear a Truss

**We Guarantee
Your Comfort**

with every Brooks' Appliance. New discovery. Wonderful. No obnoxious springs or pads. Automatic Air Cushions. Binds and draws the broken parts together as you would a broken limb. No laces. No plasters. No ties. Durable, cheap. Sent on trial to prove it. Full information and booklet free.

C. E. BROOKS
203D State St. Marshall, Mich.



Life or Death

By CHARLES S. WOLFE

(Continued from page 847)

"My picture," she said, coolly, "I believe that you newspaper people attach considerable value to photos. I had it ready for you."

"But—" I began, to be checked by a gesture.

"And now, Mr. Roberts, for your story." She settled herself comfortably in her chair. "For the last several months—a couple of years, to be more exact—I have been at work endeavoring to prove or disprove a theory that I had formulated. My work is about completed, I have been successful beyond my expectations, and I am ready to give my results to the world."

I nodded to show that I was following, and awaited further developments.

"You are thinking, perhaps, that such matter were best published in a medical journal. Well, undoubtedly, they will devote considerable space to me in the near future. But the treatment will be of such a technical nature that to the man on the street it will mean nothing, if, indeed, he gets a glimpse of the articles at all. My work is of such a revolutionary nature that I want every one to know of it, to realize what it means to each and every individual, and the best medium for such a widespread announcement is the daily press. I selected your paper as a starter. You will have what you call a scoop."

"Good night!" I thought, "our promising story dwindles to a doctor seeking sensational advertising for a pet cure. Some nerve! Wow!"

Then she puts over the knock-out punch. "I have conquered death," she said, quietly, coolly, confidently.

Believe me, I sat up quickly and began to look her over, hard, a fact that did not escape her keen eyes.

"I am not insane, Mr. Roberts, nor am I addicted to drugs or intoxicants. That statement startles you, of course, but can you think of any good reason why death should not be conquered, just as typhoid, for instance, has been mastered?"

I had no ready answer for that, but I was far from ready to believe her statement. "The thing is impossible, Doctor," I blurted. "You can make temporary repairs, and all that, but we all must die, and—"

"We always will," she finished, taking the words out of my mouth. "Yes, Mr. Roberts, that has been a foregone conclusion for ages, and for that reason more than any other, I suppose, few have ever dared tackle the problem of beating back the ancient enemy. Nevertheless, I say to you now that very few of us need die. What is more, I am prepared to prove my words. Do you think that this will make sensational enough reading for your subscribers?"

"If there was the remotest possibility of this thing being accomplished—or accomplishable, for that matter," I said, slowly, "it would be the story of the ages. The entire front page would be none too much space to devote to the subject. But—"

A mischievous gleam twinkled in her eyes. "I'll wager your Christian name is Thomas, Mr. Roberts," she laughed.

"What?" I asked, amazed, and then, catching her mood, I laughed too. "No, it's not," I retorted, "but I was born in Hannibal."

"Well," she replied, growing grave again, "I'll demonstrate, Missourian. Get

Are You A Reject?



—Like a damaged product of the factory?

Look in the glass. See if what you see there is a full fledged man, or a piece of damaged goods—a reject of society—nerves gone, vitality sapped, energy lacking, ambition lost—a weakened, trembling, hopeless, joyless mortal who feels that life is not worth living, and the world looks dark and gloomy.

The guilty man shudders at the spectacle he sees in the mirror. You know when you are face to face with yourself what has made you what you are, if you are of the guilty ones.

Don't Be a Half-Baked Misfit

You can brace up and be a real fellow—a wholesome looking, handsome, healthy chap—a man any employer would be glad to have around—a man every man and woman will instinctively take to right off. Yes, you can do it—if you will listen to a little common sense as it is taught by a man who made himself the best physical specimen in the world, then devoted himself to the rehabilitation of other men and women and so succeeded that thousands now acclaim him the wonder-worker of the age.



Strongfortism Will Put You on Your Feet

Strongfortism works miracles in men, yet it is easily adopted that, without interfering with any ordinary occupation, you can have health and vitality and vigor restored. If you are a sufferer from Nervous Disorders, Bad Habits, Excesses, Weaknesses, Catarrh, Indigestion, Rheumatism—or any other dread affliction. I urge you to learn what I can do for you. So wide-reaching is my system that I can remedy almost any physical fault by purely natural means without the use of drugs or medicines. It's great—you'll admit it as soon as you know anything about it. My Free Book tells all about it.

Send for My Free Book

I know I can confer upon you tremendous benefits—I know you'll thank me as other thousands have—that's why I want to give you an insight into my wonderful method by sending you my highly interesting and valuable book, "Promotion and Conservation of Health, Strength and Mental Energy." Don't lose a minute. Send a 10c piece for postage, etc., to my address. Tell me your ailment. I will reply promptly—you'll devour the truths found in my book and you will see at once that a new era of life is within your grasp.

STRONGFORT The Perfect Man

LIONEL STRONGFORT
Physical and Health Specialist
Dept. 153 Newark, N. J.

FREE CONSULTATION COUPON

Absolutely Confidential

Mr. Lionel Strongfort—Dept. 153, Newark, N. J. Personal—Please send me your book, "PROMOTION AND CONSERVATION OF HEALTH, STRENGTH AND MENTAL ENERGY," for postage on which I enclose a 10c piece.

Send me special information on subjects marked X below, without in any way obligating me.

- | | | |
|------------------------|-----------------------|------------------------|
| ..Colds | ..Stomach | ..Skin Disorders |
| ..Catarrh | ..Disorders | ..Impotency |
| ..Hay Fever | ..Constipation | ..Great Strength |
| ..Asthma | ..Biliousness | ..Falling Hair |
| ..Obesity | ..Torpid Liver | ..Weak Eyes |
| ..Headache | ..Indigestion | ..Pimples |
| ..Thinness | ..Nervousness | ..Blackheads |
| ..Rupture | ..Poor Memory | ..Round Shoulders |
| ..Lumbago | ..Rheumatism | ..Lung Troubles |
| ..Neuritis | ..Gastritis | ..Female Disorders |
| ..Neuralgia | ..Heart Weakness | ..Weak Back |
| ..Flat Chest | ..Poor Circulation | ..Muscular Development |
| ..Deformity (Describe) | ..Increased Height | ..Advanced Course |
| ..Insomnia | ..Successful Marriage | ..Healthy Children |
| ..Vital Depletion | ..Easy Child-birth | ..Manhood Restored |
| ..Youthful Errors | ..Despondency | |
| ..Short Wind | | |
| ..Flat Feet | | |

Here mention other subjects not listed above:

Name

Age..... Occupation.....

Street

City..... State..... S. & I.

RADIO APPARATUS

Distributors of Reliable Radio Apparatus for Experimenters in Every Branch of the Radio Field!



"Pittsco" the Sign of service!

All we ask is a trial!

AMPLIFYING TRANSFORMERS

No. A-2 Acme, mounted	\$7.00
No. A-2 Acme, semi-mounted	5.00
No. A-2 Acme, unmounted	4.50

VACUUM TUBES

Moorhead Electron Relay, detector	6.00
Moorhead Amplifier, oscillator	7.00
Moorhead Extra Hard, transmitting	7.50

B BATTERIES

No. 7623 Standard, 22.5 V. Small	1.50
No. 7625 Standard, 22.5 V. Large	2.85
No. 7650 Standard, 22.5 V. Variable	3.50

TELEPHONES (Pair)

No. 55 Murdock, 2,000 ohms	4.50
No. 55 Murdock, 3,000 ohms	5.50
Brandes Superior, 2,000 ohms	7.00
Baldwin's Type C Navy Standard	16.50
Baldwin's Type E Super-sensitive	20.00

"MANUAL" No. 22 Sent for 10 Cents in Stamps

F. D. PITTS CO. Inc.

12 Park Square, Dept. D, Boston, Mass., U.S.A.

No Seals-No Secrets

—But Service!

Inspection of the interior of any Radio apparatus bearing the mark:



reveals design and workmanship fully in keeping with its outward appearance.

GREBE RADIO apparatus is licensed under the original Armstrong and Marconi patents.

Our guarantee is absolute and unconditional. Each instrument must give satisfactory service. Our interest in the purchaser does not terminate with the sale.

Ask your dealer to show you our line of super-grade apparatus. If he doesn't carry it, write us—mentioning his name—for catalogue.

A. H. GREBE & CO., Inc.,

70 Van Wyck Blvd., Richmond Hill, N.Y.

Materials and Parts

for that new set you are building, we have it.

Brass sheet, round and square rods, sheet aluminum, fibre, bakelite and hard rubber cut to size, machine and wood screws, binding points, switch points, knobs, insulators switches, all types; variable and fixed condensers, and card board tubing. Murdock, Acme, Tresco, Bunnell, Parkin, Moorhead and Burgess products in stock, and we can give you the service you want. Our new catalogue sent for five cents, which will be refunded on first order for one dollar or over.

Try us on your next order.

Keystone Radio Co.

Drawer 307 Greenville, Pa.



LEARN WIRELESS

at the largest radio school in the Central States. Modern complete equipment. Experienced instructors. Dormitory in connection. Students may earn expenses if necessary. Write today for catalogue and full information.

CENTRAL RADIO SCHOOL Independence, Mo.

your note-book, and I'll give you an outline."

Undecided as to whether I was up against mania, colossal nerve, or a practical joke, I complied, my mind striving desperately to read this riddle. I was getting a sensation—all right.

She leaned back, rocking gently in the swivel-chair, placed her finger tips together, and began to speak, rather dreamily.

"Barring accident, of course, which is an artificial form of demise, due largely to our clumsy man-made mechanical contrivances, what is the primary cause of death?"

Sharpening my pencil, I replied rather flippantly, and certainly without any thought, "The heart ceasing to beat."

"Exactly," she cried, rousing. "The heart stops beating! That is the only cause of death. There may be any number of things, and numberless combinations of things, which act to produce this effect. But they are only instrumentalities. They are merely means to an end. There is no death until the heart ceases to function. Even if death be due to violence, this is true. You admit this?"

"Certainly," I answered, readily, "it is obvious."

"Very well. Then, if you are logical, you will admit also that we have only to find some means to prevent the heart from ceasing its working, and we have defeated death and dissolution."

"But—," I began, feeling that I had no adequate answer, yet with some big objection struggling within me for utterance.

"What you are going to say," she interrupted, "whatever form it takes, will simply amount to stating the fact that heretofore nothing has been found that will prevent the heart from stopping. That is true. But it is equally true that prior to the demonstration of the Wrights, no means had been found to sustain a machine heavier than air in flight. And that prior to Hertz's discoveries no means had been found to hurl energy thru miles of space with no tangible medium to aid the passage. And that, so far, no way has been found to bridge the void between planets. It does not say that in the first instances it was not found, nor that in the last that it will not be found. It seems incredible, as the others seemed incredible. In the light of what has already been accomplished, does not the future hold promise of things even more unbelievable than the statement that I have made to you this evening?"

"It at least earns for you a further hearing," I conceded, gracefully.

"Well," she resumed, "that was the theory upon which I began work. Realizing that death was a simple thing, depending only on that one condition, I began my quest for the cause of that condition, disregarding altogether the thousand and one forms in which the approach of the phenomenon heralded itself.

"After some research, I formulated the working hypothesis that the heart was overpowered by one thing only, and I then began a quest for an active principle, whose presence in some quantity in the heart would cause it to cease its beating."

I ventured a question. "Why just one cause?" I queried. "I am not up in these lines, but it seems to me that it might be stopt by any one of a dozen causes. In the case of old age, for instance, it might just simply wear out."

"That same statement has been made by many a medical man," she answered, "but I invite you to consider a very significant fact. Regardless of the cause of death, the heart undergoes no material change. It simply stops, that's all. It does not shrink. It does not disintegrate. It does not change its form. A shoe, for a concrete instance, in wearing out shows visible signs

GENUINE ASPIRIN

Name "Bayer" means genuine

Say "Bayer"—Insist!



Say "Bayer" when buying Aspirin. Then you are sure of getting true "Bayer Tablets of Aspirin"—genuine Aspirin proved safe by millions and prescribed by physicians for over twenty years. Accept only an unbroken "Bayer package" which contains proper directions. Handy tin boxes of 12 tablets cost few cents. Druggists also sell larger "Bayer packages."

BAYER-TABLETS of ASPIRIN

Aspirin is the trade mark of Bayer Manufacture of Monoaceticacidester of Salicylicacid

Used by 4,000,000 People Annually

Prepared with Predigested Organic Iron—Easily Assimilated by the Blood

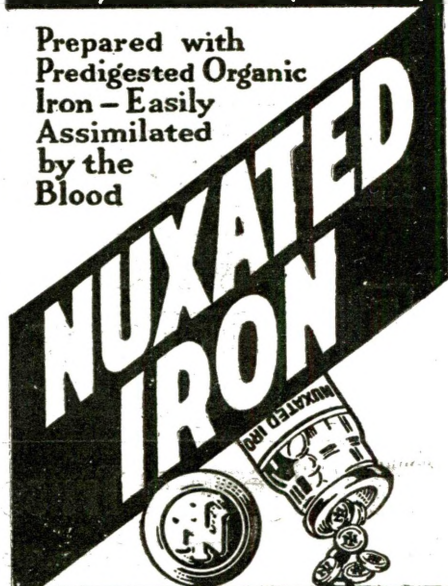

For Red Blood, Health and Strength

"FIBRE-LITE" LIMBS

Easy Payments—Do Nature's Work. AGENTS WANTED who wear leg. Good Pay. FREE Fibre Sample. Describe Stump to WORMAN CO., 252-D HENNEPIN, Minneapolis, Minn.

of the process. A limb, becoming paralyzed or useless, shrivels. In nearly everything which is reaching the end of its usefulness we find the evidence of change. Not so the heart. There is only one thing of which I can think, off-hand, which does not suffer to a great extent physical changes in reaching the end of its string."

"And that is—" I asked, interested deeply.

"A battery, more particularly a dry cell. If we disregard the attack on the zinc element, which is not so great, we find that its end is brought about for the reason that chemical reactions have taken place—it has polarized. I conducted my search for something that would—in effect—polarize the heart."

I looked up from my scribbling, struck by a thought which I hastened to voice. "Seems to me that in school we used to get a lot of stuff about anabolism and catabolism, and that sort of thing. I'm hazy on it at the present, but if I remember rightly the gist of it was that when the destructive process began to work faster than the constructive forces, the victim presented a pleasing aspect to the family undertaker."

Undaunted by my feeble attempt at humor, she countered. "Quite true, but the fact overlooked by many is that the destructive process cannot begin until the heart starts to waver under the first attack of this virulent principle of which I spoke. So long as the organ is functioning normally, construction keeps easily ahead of destruction. But at the first indication that the reverse is true, you may rest assured that there is beginning to collect within the heart this principle which I succeeded in isolating.

"Which brings us to the point. I did succeed in isolating it. Let me show you."

She swung to the desk again, to face about again with a half-ounce phial in her hand. She held it up to the light. It was of a peculiar, sickly green hue, and as the level of the fluid changed as she shifted the phial, I noted that it stuck to the sides of the bottle in oily drops.

"What is that stuff?" I asked, regarding it disapprovingly. It was, for some reason, repugnant.

"I have not given it a name as yet," she said, calmly. "But let me tell you this. All known poisons pale into insignificance in comparison to this. In fact, it is the real active principle in every poison. A poison is only a poison because it contains this principle in sufficient proportion to completely polarize the heart, if I may use that expression.

"Further, I have made exhaustive tests of its power. I was amazed at the truly minute quantity of this liquid which would produce death. Science has found ways to measure the infinitely small, but I had to devise several entirely new instruments to measure the dose necessary for fatal results. There is enough in this bottle to wipe out a nation."

"For Heaven's sake," I gasped, "what is a lethal dose of that stuff?"

"As nearly as I can tell you, an atom and a half," she replied.

"An atom and a half," I echoed. "That would be small, wouldn't it?"

She smiled. "Quite," she said, dryly. "To resume, and to be brief, my next logical step was to find an antidote for this terrible poison that I had discovered. This I have done. And that is why I sent for you. I am prepared to demonstrate that I have an antidote for death itself. Let me give you a convincing demonstration."

From under the desk she brought to light a small cage, and a series of squeals betrayed the fact that it contained some living animals. In a moment these proved to be white rats.

YOU Can Easily BUILD This PHONOGRAPH

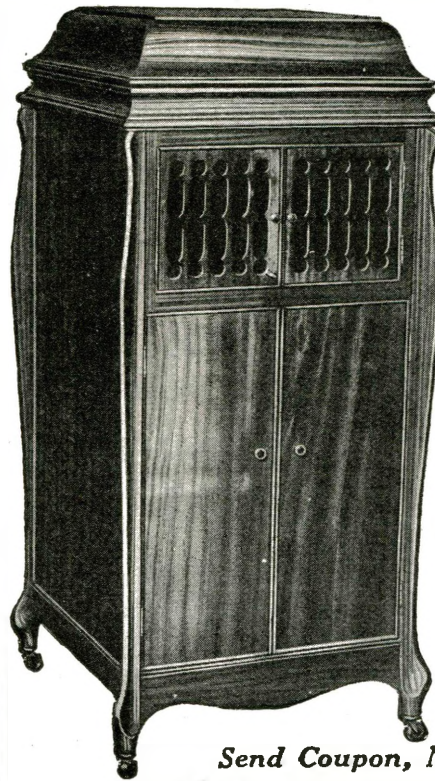

TREMENDOUS SAVING IN COST

You don't need to be a cabinet maker. We have made it an easy and pleasant job with

Our Simplified Plans We furnish blue prints, diagrams, motor, ready-built horn, cabinet pieces and all metal parts complete. You do the assembling, **6 models to choose from.** A few hours' work, and you will have as fine a type of phonograph as any produced, and at a price away below what you would pay in a store.

KEEP THE SAVINGS IN YOUR POCKET

Machines play all records, have a wonderful tonal quality, excelled by none. No need now for any family to be without a phonograph because of the cost. **THE MAKAFONE** solves the problem. **BUILD IT YOURSELF AT LESS THAN ONE-FOURTH REGULAR COST,** but equal to the high-priced cabinet machines. Free Records with each outfit. **SEND TODAY FOR FREE CATALOG** and full particulars of our wonderful offer. *Many a manufacturer got his start in this way. Why not you? Build machines and sell to your friends.*

Agents Attention You can sell these machines from our plans at a profit of \$50 to \$75 each. Others are selling two and three a week. Here is your opportunity to make big money and become independent. Pleasant and profitable work.

Modern Phonograph Supply Co.
393 Springer Bldg.
313 So. Clinton St., Chicago, Ill.
Gentlemen: Please send me full particulars of your Makafone proposition, without obligation to me.
Name
Address..... State.....

Send Coupon, Now—To-day

MODERN PHONOGRAPH SUPPLY CO.

393 Springer Bldg., 313 So. Clinton Street, Chicago.

The Third Edition of the—Consolidated Radio Call Book

Officially lists all the radio calls as issued by the Bureau of Commerce. Every vessel and land station in the world will be represented and listed alphabetically, according to names of vessels or land stations, and according to call letters; Revision of American coastal stations under U. S. Naval control and their new calls.

**All Amateur Calls Also Listed
Order Your Copy NOW!**

Each of the two preceding editions were immediately exhausted. By placing your order now you are assured one of the first copies off the press.

Price \$1.50

For sale at all leading dealers or order from us direct.

CONSOLIDATED RADIO CALL BOOK CO., 41 Park Row, New York City



NEW MOTORS FACTORY GUARANTEED ALL SIZES PROMPT DELIVERY

- Charging Generators**
Suitable for all lighting. Battery Charging and Power Requirements.
- 8 v., 10 amp. .. \$19.50
 - 15 v., 10 amp. .. \$26.50
 - 40 v., 6 amp. .. \$31.50
 - 110 v., 2 1/2 amp. .. \$31.50
 - 110 v., 5 amp. .. \$52.50
 - 40 v., 12 amp. .. \$52.50
 - 110 v., 9 1/2 amp. .. \$67.50
 - 40 v., 25 amp. .. \$67.50
 - 110 v., 18 amp. .. \$116.50
 - 40 v., 50 amp. .. \$116.50
 - 110 v., 26 amp. .. \$156.50
 - 110 v., 50 amp. .. \$238.50
 - Moving Picture Arc Generator 60 v., 35 a. .. \$116.50

- Polyphase Motors**
2 and 3 phase, A. C., 240 v., 60 c., 1750 R.P.M., Complete with base and pulley.
- 1/2 H.P. - \$46.50
 - 1 H.P. - \$66.50
 - 2 H.P. - \$86.50
 - 3 H.P. - \$98.50
 - 5 H.P. - \$116.50
- Direct Current Motors**
110 or 220 volts, D. C., shunt wound, 1750 R. P. M. With base pulley and starting box.
- 1/4 H. P. Washing Machine Motor - \$28.50
 - 1/4 H. P., 31 v. Washing Machine Motor - \$28.50
 - 1/2 H. P. . . . \$58.50
 - 1 H. P. . . . \$82.50
 - 2 H. P. . . . \$124.50
 - 3 H. P. . . . \$142.50
 - 5 H. P. . . . \$218.50
- Single Phase Motors**
110-220 volts, A. C., 60 cycle, 1800 R. P. M. with pulley
- 1/4 H. P., 230 v., Induction Washing Machine Motor - \$28.50
 - 1/4 H. P., 110 v. grinding belling motor - \$28.50
 - 1/2 H. P. induction, full load start - \$46.50
 - 1/2 H. P. repulsion induction For compressor service - \$54.50
 - 1 H. P. repulsion induction, Special Garage Motor - \$74.50
 - 2 H. P. repulsion induction with sliding base - \$126.50
 - 3 H. P. repulsion induction with sliding base - \$146.50
 - 5 H. P. repulsion induction with sliding base - \$188.50

WRITE FOR CATALOG. BARGAINS IN MOTORS AND GENERATORS

1/4 SPECIAL 110 volts 50 c. S. P., 1750 R.P.M. Complete, cord, plug and pulley

WASHING MACHINE MOTORS
Suitable for operating Small Compressors, Coffee Grinders, Bottle Washers, Etc. Reg. Val. \$34.50

\$26.50 Each

MONEY BACK GUARANTEE

SHIPPING TERMS: 15% deposit required on all orders. Balance C. O. D. by Express. Sight draft with Bill of Lading attached by freight.

MANUFACTURERS' DISTRIBUTOR
CNAS. H. JOHNSTON, Box 12, West End, Pittsburgh, Pa.

AMATEURS

Get the whole efficiency out of your set by installing a combination of the MOORHEAD A-P ELECTRON RELAY as a detector and one or more A-P V. T.'s as amplifiers.

Electron Relay - - \$6.00 *Amplifier* - - \$7.00

SPECIAL FOR THIS MONTH ONLY—We will give free with every tube sold 15 nickel contact points.

WHITALL ELECTRIC COMPANY
42 Main Street Westerly, R. I.

Call Letters I. I. A. P.

WRITE FOR SPECIAL PRICE FOR MORE THAN ONE BULB—YOU CAN SAVE MONEY

TYPE Z.R.F. REGENERATIVE RECEIVER

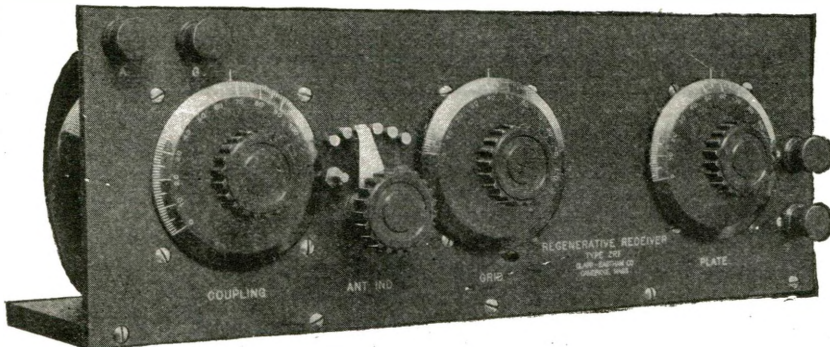

WE invite your comparison with any set of similar type for performance or quality. Range 175 to 600 meters. Price complete, \$38.00. Variometer, only \$6.50.

Our Radio Products have been established in their leadership for thirteen years, are carried in stock by discriminating dealers and are manufactured at 139 Main Street, Cambridge, Mass., by

CLAPP-EASTHAM COMPANY

Catalogs mailed for 6c stamps

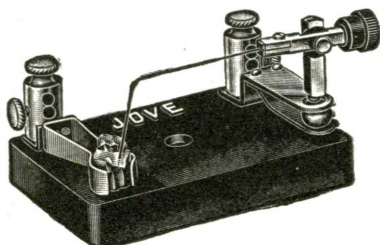

(GHEGAN PATENT)

Bunnell INSTRUMENTS Always Reliable

JOVE DETECTOR

Handiest, Handsomest, Best
Sample by Mail — \$2.00
Tested Galena Crystal—25c

Distributors of Standard Electric Novelty Company Type B "Cyclone" Audion Batteries. Also De Forest, and all other makes of High Class Wireless Apparatus.

Send stamp for new edition 42E Catalog.

J. H. BUNNELL & CO., 32 Park Place, New York



8 State St., New York, N. Y.

Phone Bowling Green 8079

Complete instruction in radio operating in all branches for Merchant Marine, Ocean Steamships, Telegram Service. Special course in Vacuum Tubes and Radio Telegraphy. Preparing for Government Examinations.

Elementary and Advanced Classes
Day and Evening Classes

Write for Circular.

Coolly she went about her preparations. An ordinary hypodermic syringe was produced, and a tumbler of a liquid which may have been, and probably was, water. Uncorking the terrible green bottle, she seemed to me to merely waive it over the tumbler. Certainly there was no perceptible coloring of the fluid. The amount added had indeed been minute. From the tumbler she filled her syringe. Deftly she drew one of the rats from the cage, and quickly administered the injection.

For an instant the rat seemed to sit motionless on the desk-top. Then a convulsive shiver shook its frame, and it seemed to stiffen imperceptibly.

"Dead!" said Doctor Weeks, glancing at me significantly. "Heart failure."

From a pigeon-hole of the desk she drew a second phial, this time filled with a black solution. "The antidote," she said.

Another rat was drawn squirming from its cage. Holding and soothing it, she faced me. "And now, Mr. Roberts," she said, "you will see how completely my antidote overcomes the Master Poison. I propose to inoculate this rat with the same syringe that caused the death of the first one. We will even let apparent death ensue. Then we will use the antidote. Watch closely, please."

I bent forward, tensely, in my chair. The deadly hypodermic was administered. Doctor Weeks placed the syringe upon the desk-top, and gazed down quizzically as the second rat gave the convulsive movement that had marked the passing of his predecessor.

"And now—" she cried, seizing a fresh syringe and the antidote bottle, leaning forward to give the saving injection. It was never given. There arose a terrible hoarse cry. She jerked erect, the antidote phial and syringe crashing from her hand. I shall never forget the imploring look she gave me in that brief second, never. Instantly I realized what had happened. She had lunged forward and struck that impregnated needle with her bare arm. And as I struggled to my feet she crumpled to the rug.

In her fall, the uncorked antidote bottle which she held in one hand, and which might have saved her, had emptied on the rug, spilling every drop of the precious liquid.

I called loudly for her servant stooping frantically over her. The servant rushed into the room. "Telephone for the nearest doctor," I ordered, "and tell him to come quickly!"

All my efforts to revive her were in vain. I thought me of the antidote. Quickly, desperately, I picked up the phial from the floor where it had fallen. It was empty, every drop having been absorbed by the rug.

I continued my efforts until the summoned physician arrived. He bent over the prostrate form, an exploratory hand seeking the breast. Finally he straightened up with the customary deprecatory shrug of the medical man faced by a hopeless task. "Heart failure," he said, briefly.

Sorrowfully I carried my tale back to the city editor. We couldn't use it, of course. But now, a year later, it dawns on me that possibly some other medical student might attempt the search again—that is, if he thinks Doctor Weeks was sane.

MAKING THE SAFFIRE BLUSH.

The existence of the electric furnace makes it possible to create diamonds that are the veritable stone, and to fuse chip-pings and fragments of ruby into one complete jewel. Now arrives a report that with the aid of radium successful transformations have been made in the appearance, if not in the nature, of certain precious stones. A saffire, it is said, has been turned into a glorious ruby by long exposure to the effect of radium.

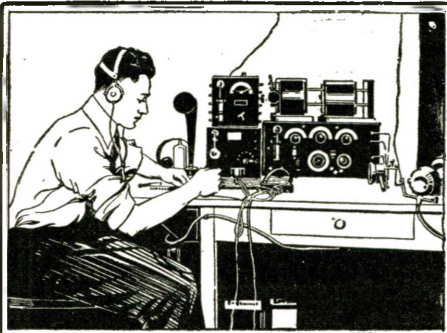

IT will pay you to learn Radio by our new and comprehensive method in a few months of evening study. We prepare you to meet all the new requirements for first grade commercial license, and obtain position paying \$125.00 a month and expenses. Moderate tuition fee.

Write for Booklet B

Y. M. C. A. RADIO SCHOOL
 Marcy Avenue, Near Broadway
 Brooklyn, N. Y.
 Telephone Williamsburg 3800

The WIRELESS EQUIPMENT COMPANY, Inc.

Furnishes all kinds of reliable radio apparatus at lowest prices. Send for latest bulletin No. 151C on new apparatus.

188-190 Greenwich St. New York

\$10 Brings This Latest Model **L. C. Smith or a Remington TYPEWRITER**



Thoroughly rebuilt in our factory by the famous "Young Process." Fully guaranteed. Easy terms. No interest. **FREE TRIAL.** We handle all standard makes. Write for details. **YOUNG TYPEWRITER CO., Dept. 44 Chicago**

Audion Control Unit \$15.00

Type A1, absolutely reliable, can be used with every known circuit. Cabinet size 8 1/2 x 6 1/4 x 6 1/4". Mahogany finish, contains Vacuum tube socket, filament rheostat, grid condenser, grid leak and filament switch. Whole back of cabinet swings open, giving ready access to interior.

At your dealer or from us.

K. & G. WIRELESS SUPPLY CO.
 Dept. 15A 152 Chambers St., N. Y.

YOU Can Double Your Ability to Earn Money! Hold Friends! Win Love and Happiness! Our System of Personal Efficiency tells you how! Success Studygram and Personality Sketch for 10c and birth date. Thomson-Heywood Company, Dept. 350, Chronicle Building, San Francisco.

DOLLARS IN HARES

We supply guaranteed high grade stock and buy back all you raise at \$7.00 to \$15.50 and up a pair, and pay express charges. Big Profits. Use back yard, barn, cellar, attic. Contract and Illustrated Catalog Free. **STANDARD FOOD & FUR ASSOCIATION**
 409Z Broadway - New York



BE AN EXPERT

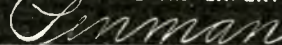

Wonderful, new device, guides your hand; corrects your writing in few days. Big improvement in three hours. No failures. Complete outline **FREE**. Write C. J. Ozmert, Dept. 44, St. Louis, Mo.

Wrestling Book FREE

Be an expert wrestler. Learn at home by mail. Wonderful lessons prepared by world's champions Farmer Burns and Frank Getch. Free book tells you how. Secret holds, blocks and tricks revealed. Don't delay. Be strong, healthy. Handle big men with ease. Write for free book, State age. Farmer Burns, 1229 Gange Bldg., Omaha, Neb.

Practical Chemical Experiments

(Continued from page 920)

Order of Activity of the Metals: Chemists arrange the metals according to their relative degrees of activity. The order is such that any metal in this table will replace from its solution any metal that follows it and will itself be replaced from solution by any metal that precedes it. This chemical fact is stated in another way as follows: Any metal in the table is negative with respect to any metal that follows it and positive with respect to any metal that precedes it. Very important chemical facts result from this simple relationship.

Replacement of one Metal by another: In separate test tubes place solutions of lead nitrat, copper sulfate, silver nitrat and mercury nitrat. Label the test tubes so that you will be able to identify them and drop into each a strip of sheet zinc about 10 cm. long and 1 cm. wide.

In another set of test tubes containing solutions of lead nitrat, silver nitrat, zinc nitrat and mercury nitrat place strips of copper.

Allow these test tubes to stand undisturbed for about fifteen minutes. Then observe what has happened. In the first set of test tubes there seems to be a deposit in each case except that of the mercury. But remove the zinc strip from the mercury solution and rub it. It immediately assumes a bright silvery lustre. Break the zinc strip and, unlike the original zinc, you will find it very brittle and the bright lustre seems to extend clear thru the metal. The zinc has replaced the mercury in the solution and since mercury amalgamates with many metals it has penetrated the zinc and alloyed with it.

If allowed to stand the copper sulfate solution will lose its blue color because all of the copper will have been driven from solution. The lead appears as a spongy grayish deposit, while the silver has a very peculiar appearance totally unlike the familiar white metal. If the strip of copper placed in the silver nitrat is allowed to remain for some time, a distinct bluish tinge will be seen upon looking down into the test tube showing that the copper has gone into solution. Remove this strip of copper and carefully scrape off some of the spongy deposit. Place it on a square of glass and rub it with the end of a glass rod. The bright white lustre of silver will at once appear.

It will be noted that, altho zinc replaces copper, the copper does not replace zinc.

Applications of the above Facts: Because zinc is negative with respect to copper we use these two metals in the making of electric cells. If strips of zinc and copper are placed in a solution of dilute sulfuric acid and connected in external circuit, the zinc having greater activity than copper goes into solution, driving positive hydrogen ions over to the copper and causing it to become positively charged while the zinc itself remains negatively charged.

Local action in a cell is caused from the fact that zinc is negative with respect to the little impurities of carbon that it contains, and therefore a multitude of tiny electric cells are set up over the surface of the zinc, causing it to go into solution. Copper is electro-positive with respect to iron and therefore copper rivets cannot be used on iron sheeting, especially if it is to be used in salt water. If they are the iron will immediately be eaten away.

Zinc is an excellent coating for iron because, being negative with respect to it, the zinc must oxidize entirely away before any of the iron will rust. And since zinc oxidizes very slowly the iron is preserved for a long time.

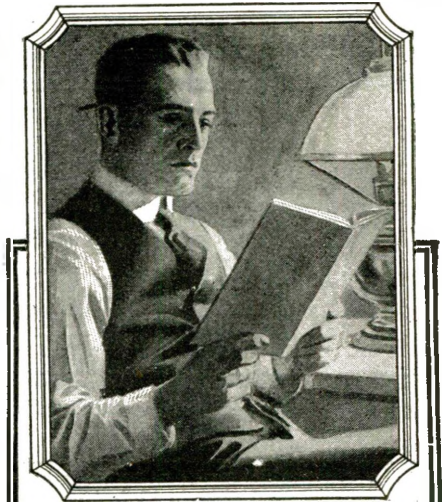

\$95 An Hour!

"Every hour I spent on my L. C. S. Course has been worth \$95 to me! My position, my \$5,000 a year income, my home, my family's happiness—I owe it all to my spare time training with the International Correspondence Schools!"

Every mail brings letters from some of the two million I. C. S. students telling of promotions or increases in salary as the rewards of spare time study.

What are you doing with the hours after supper? Can you afford to let them slip by unimproved when you can easily make them mean so much? One hour a day spent with the I. C. S. will prepare you for the position you want in the work you like best. Yes, it will! Put it up to us to prove it. Mark and mail this coupon now!

INTERNATIONAL CORRESPONDENCE SCHOOLS
 BOX 6173-B SCRANTON, PA.

Explain, without obligating me, how I can qualify for the position, or in the subject, before which I mark X.

- | | |
|--|--|
| <input type="checkbox"/> ELECTRICAL ENGINEER | <input type="checkbox"/> CHEMICAL ENGINEER |
| <input type="checkbox"/> Electrician | <input type="checkbox"/> SALESMAN/SHIP |
| <input type="checkbox"/> Electric Wiring | <input type="checkbox"/> ADVERTISING MAN |
| <input type="checkbox"/> Electric Lighting | <input type="checkbox"/> Window Trimmer |
| <input type="checkbox"/> Electric Car Running | <input type="checkbox"/> Show Card Writer |
| <input type="checkbox"/> Heavy Electric Traction | <input type="checkbox"/> Outdoor Sign Painter |
| <input type="checkbox"/> Electrical Draftsman | <input type="checkbox"/> RAILROADER |
| <input type="checkbox"/> Electric Machine Designer | <input type="checkbox"/> ILLUSTRATOR |
| <input type="checkbox"/> Telegraph Expert | <input type="checkbox"/> DESIGNER |
| <input type="checkbox"/> Practical Telephony | <input type="checkbox"/> BUSINESS MANAGEMENT |
| <input type="checkbox"/> MECHANICAL ENGINEER | <input type="checkbox"/> Private Secretary |
| <input type="checkbox"/> Mechanical Draftsman | <input type="checkbox"/> BOOKKEEPER |
| <input type="checkbox"/> Ship Draftsman | <input type="checkbox"/> Stenographer and Typist |
| <input type="checkbox"/> Machine Shop Practice | <input type="checkbox"/> Cert. Pub. Accountant |
| <input type="checkbox"/> Toolmaker | <input type="checkbox"/> Traffic Management |
| <input type="checkbox"/> Gas Engineer | <input type="checkbox"/> Commercial Law |
| <input type="checkbox"/> CIVIL ENGINEER | <input type="checkbox"/> GOOD ENGLISH |
| <input type="checkbox"/> Surveying and Mapping | <input type="checkbox"/> STATIONARY ENGINEER |
| <input type="checkbox"/> MINE FOREMAN OR ENG'N | <input type="checkbox"/> CIVIL SERVICE |
| <input type="checkbox"/> ARCHITECT | <input type="checkbox"/> Railway Mail Clerk |
| <input type="checkbox"/> Architectural Draftsman | <input type="checkbox"/> Textile Overseer or Supt. |
| <input type="checkbox"/> PLUMBING AND HEATING | <input type="checkbox"/> AGRICULTURE |
| <input type="checkbox"/> Sheet Metal Worker | <input type="checkbox"/> Poultry Raising |
| <input type="checkbox"/> Navigator | <input type="checkbox"/> Automobiles |
| | <input type="checkbox"/> French |
| | <input type="checkbox"/> Italian |

Name _____ 7-25 19
 Present Occupation _____
 Street and No. _____
 City _____ State _____

Send No Money

Free Trial

We will send you any of the new Pathe Phonographs with your own selection of Pathe Records without a penny down. Test them for 10 full days. If you decide to buy, pay the lowest cash price in a small monthly amount. If it fails to please, send it back at our expense.

Easy Terms

Pathe Phonographs are known and loved by millions on two continents. It is the acknowledged standard of the world. In its library are over 75,000 selections—and it plays all other records, too. No needles to change. It costs no more than the ordinary phonograph.

Pathe Book Free

Send name and address today. No obligations.

The Standard Phonograph Co.
 Dept. 1208 - Chicago, Ill.

Opportunity Ad-lets

YOU will find many remarkable opportunities and real bargains in these columns. It will pay you to read and investigate the offerings made every month by reliable firms, dealers and amateurs from all over the country. No matter what you may be seeking, whether supplies, automobile accessories, the opportunity to make money, or anything else, you will find listed here the best and most attractive specials of the month.

Advertisements in this section ten cents a word for each insertion. Name and address must be included at the above rate. Cash should accompany all classified advertisements unless placed by an accredited advertising agency. No advertisement for less than 10 words accepted. Ten per cent. discount for 6 issues, 20 per cent. discount for 12 issues. Objectionable or misleading advertisements not accepted. Advertisements for the February issue must reach us not later than December 22.

The Circulation of Science and Invention is over 140,000 and climbing every month

EXPERIMENTER PUBLISHING CO., INC., 236 Fulton Street, New York City, N. Y.

Auto Accessories

Battery charger for garage or service station. Terms if desired. HB Company, Troy, Ohio.

Autoists. "Saviorgas" made at home. More power. Less carbon. Recipe 10c. Hawthorne Recipe Co., Roslyn, Wash.

Tire Agents. Exclusive representatives to use and sell the new Mellinger Extra-Ply Tires. (No seconds.) Guarantee Bond 8,000 miles. Wholesale prices. Sample sections furnished. Mellinger Tire Co., 980 Oak, Kansas City, Mo.

Auto Motor Supplies—Buick, Michigan, Stoddard-Dayton, Cadillac-Overland, E. M. F. Continental and Buda Motors, all types, \$50 each and up. Special high-tension, 2 and 4 cylinder magnetos \$9.50 each. Electric and gas head lamps, coils, carburetors, air compressors, generators, starters, etc. Write for catalog. Address Motor Sales Dept. (12), West End, Pittsburgh, Pa.

Save money on accessories. Any kind. We wholesale to consumers. 25% less than retail. Write your wants and get our prices. Guaranteed Auto Parts Co., 105 W. Monroe, Chicago, Ill.

Blueprints. Automobile Armatures. See ad under "Electrical." Charles Chittenden.

Fords start easy in cold weather. Will run 34 miles per gallon on cheapest gasoline or half kerosene, using our 1920 carburetors. Increased power; styles for all motors; can attach them yourself. Big profits to agents; money back guarantee; 30 days trial; Air Friction Carburetor Co., 1511 Madison St., Dayton, Ohio.

Motor Engines and Dynamos

Small motors and generators: $\frac{1}{4}$ hp. AC \$26.50; $\frac{1}{2}$ hp. \$38.50; $\frac{3}{4}$ hp. AC \$67.50. Battery charging sets; charging lighting and moving picture arc generators; motors for all phases of current. Prompt delivery; wholesale prices. Write for late catalog. Address Motor Sales Dept. (12), West End, Pittsburgh, Pa.

Motors, generators, battery chargers, prompt deliveries. Easy terms. Write Hobartsons, Troy, Ohio.

Motorcycles—Bicycles

\$25.00 up, guaranteed rebuilt motorcycles, Henderson, Excelsior, Indian, Harley-Davidson. Bicycles \$5.00 up. Tires and accessories at wholesale. Illustrated Bulletin A free. Ash Motor Corporation, 162 N. Clinton Ave., Rochester, N. Y.

Aeronautics

Blueprints. Most elaborate sets of prints ever published for building a Ford or motorcycle motored biplane. Ford consists of 36 large sheets, motorcycle 28 sheets, all chuck full of valuable details designed by America's Oldest and best Aeronautical Engineers. Price, either set \$20.00. Send \$5.00, balance after you are convinced. Heath Airplane Co., Chicago.

Boys make a model aeroplane that will fly. Easily made at small cost. Write for circular. Aero Shop, 658 $\frac{1}{2}$ Hurlbut Ave., Detroit, Michigan.

Heath Propellers represent the most efficient method for all Aerial drive. Each propeller individually designed for the particular work to be done, as laid out by America's Oldest Aeronautical engineers. Propeller Catalog 4c. Heath Airplane Co., Chicago.

Propellers for aeroplane propulsion, small propellers for motorcycle driven snow and ice sleds, road speedsters and hydroplanes. 5 ft. diameter \$12, others in proportion. Hub mountings, bearings, sprockets, and countershafts complete. Have full scale blue prints for building Ford and Motorcycle driven sleighs. Crawford Motor and Aeroplane Mfr., 142 South Rampart St., New Orleans, La.

Heath Airplane Co.'s "Supply Catalog" is the most complete booklet ever published on aeronautical needs. 16c in stamps. Get our pamphlet on Ford and Motorcycle engine-driven airplane, 4c. Heath Airplane Co., Chicago.

Aviation-Motor 30-40 HP, 2 cyl. opposed air cooled, weight 128 lbs. ideal motor for light aeroplanes, motor sleds, wind wagons, hydroplanes, etc. Price only \$325, complete with propeller ready to run. Aircraft Inc., 338 Coney Island Ave., Brooklyn, N. Y.

Short Stories, Manuscripts Wanted

Earn \$25 Weekly, spare time, writing for newspapers, magazines. Experience unnecessary; details free. Press Syndicate, 566 St. Louis, Mo.

Short Stories, poems, plays, etc., are wanted for publication. Literary Bureau, 165 Hannibal, Missouri.

Stamping Names

Make \$19 a hundred stamping names on key-checks. Send 25c. for sample and particulars. Ex Keytag Co., Cohoes, N. Y.

Agents Wanted

Earn \$2.00 an hour. Cleaning, renovating and refinishing old floors. Complete instructions and formulas. Price \$1.00. C.C. Box 775, Chicago, Ill.

Agents. Big returns, fast office seller; particulars and samples free. One Dip Pen Co., 12 Daily Record Bldg., Baltimore, Md.

Agents make big money because sales may be made in every home. Our modern aids to home sanitation have an appeal that cannot be resisted. A brush, mop or duster for every need. Liberal commissions and good territory. North Ridge Brush Company, 127 Clark St., Freeport, Ill.

Make and sell your own goods. Formulas by Expert Chemists. Manufacturing Processes and Trade Secrets. Write for Formula Catalog. Chapin Mystic Company, Washington, D. C.

\$6000.00 a year is your profit from 4 sales a day. Davidson sold 96 one week. No experience needed. The Aladdin light is a sensation wherever introduced. 5 times as bright as electric. Won Gold Metal. Farmers have the money, they need this light and 9 out of 10 will buy. Also big opportunity in small towns and suburbs. Excellent spare time and evening seller. No capital required. Sample on free trial. Write for agency proposition while territory still open. Mantle Lamp Company, 507 Aladdin Bldg., Chicago.

Agents—\$40-\$100 week; free samples; gold sign letters; anyone can put on store windows; big demand; liberal offer to general agents. Metallic Letter Co., 433-Z, N. Clark, Chicago.

Agents. Sell our accident and sickness policies in your spare time. Pay \$5,000 death. \$25 weekly benefit. Premium \$10 yearly. Permanent income from renewals. Easy seller. Liberal commissions. Insurance Co., Dept. N-3, Newark, N. J.

Agents—Our soap and toilet article plan is a wonder; get our free sample case offer. Ho-Ro-Co., 138 Locust, St. Louis.

\$10 Daily refinishing chandeliers, brass beds, automobiles by new method, without capital or experience. Free particulars and proofs. Write today. Gunmetal Co., Avenue D, Decatur, Ill.

Men, get into the wonderful tailoring agency business, big profits taking orders and your own clothes free. We furnish fine sample outfit and everything free. No experience needed. Write today. Banner Tailoring Co., Dept. 759, Chicago.

350% profit. Quick Seller, Klean-Rite Magic Washing Compound, Washes clothes without rubbing. Sells 25c. You make 19c. Samples free. Bestever Products Co., 3253-E, Belleplaine, Chicago.

Inside Tyres, inner armor for automobile tires double mileage and prevent punctures and blow-outs; quickly applied; cost little; demand tremendous; profits unlimited. Details free. American Automobile Accessories Co., Dept. T-1992, Cincinnati, Ohio.

Big money and fast sales. Every owner buys gold initials for his auto. You charge \$1.50; make \$1.35. Ten orders daily easy. Write for particulars and free samples. American Monogram Co., Dept. 71, East Orange, N. J.

Agents wanted to sell hosiery. Everybody wears. Samples and instructions free. Hosiery House, Tappan, N. Y.

Agents go into permanent business. No capital required. Should net \$2500 to \$5000 first year. Guaranteed products needed in every home. Repeat sales—big profits. Old established concern whose products are known everywhere. Many make sales of \$40 to \$75 per day. Practical sales helps, advertising matter furnished. Sample outfit free. Write today. W. T. Rawleigh Co., 309 Liberty St., Freeport, Ill.

Help Wanted

Men, get into the wonderful tailoring agency business, big profits taking orders and your own clothes free. We furnish fine sample outfit and everything free. No experience needed. Write today. Banner Tailoring Co., Dept. 760, Chicago.

You are wanted as U. S. Government Postal Clerks. \$135-\$195 month. Men-women over 17. List positions open—free. Franklin Institute, Dept. E 25, Rochester, N. Y.

Wanted, bright young men desirous of getting into aeroplane work. Good future; advancement monthly \$2.00 per day while learning. Heath Airplane Co., Chicago.

Money in Mirrors. Tells how to cash in big. All or spare time making and resilvering mirrors. Our formula best on market. Booklet free. Wear Mirror Works, Excelsior Springs, Missouri.

Wanted. Picture play writers. Big pay. Experience unnecessary. Best course how to write and sell plays. Prepaid \$1.00. Address Studios, 856 Carpenter Ave., Oak Park, Ill.

Stop daily grind. Start silvering mirrors, auto headlights, tableware, etc. Plans free. Clarence Sprinkle, Dept. 48, Marion, Indiana.

Firemen, Brakemen, Baggage-men, \$140-\$200. Colored porters by railroads everywhere. Experience unnecessary. 897 Ry. Bureau, East St. Louis, Ill.

Earn \$25 Weekly, spare time, writing for newspapers, magazines. Experience unnecessary; details free. Press Syndicate, 5665 St. Louis, Mo.

Men—Boys. Become Automobile experts. \$45 week. Learn while earning. Write Franklin Institute, Dept. E806, Rochester, N. Y.

Men Wanted. I want a few men to train as draftsmen. Experience not necessary. Draftsmen earn \$150 to \$300 per month and more. Big demand. Splendid opportunities. Learn quickly at home. Let me send you Free Lesson. No charge. Address: Charles W. Morey, Director, 2278 Chicago Tech. Bldg., Chicago, Ill.

Be a Mirror Expert. \$3 to 10 a day; spare time home at first; no capital; we train, start you making and silvering mirrors French method. Free prospectus. W. R. Derr, Pres., 579 Decatur Street, Brooklyn, N. Y.

Get a Business College Course at Home. Prepare to earn \$100 to \$200 month. Graduates placed in good positions. Details free. Brown's Home Study School, 310-R, Peoria, Ill.

Detectives earn big money. Excellent opportunity. Travel. Great demand everywhere. Experience unnecessary. Particulars free. Write, American Detective System, 1968 Broadway, N. Y.

Be a Detective. Travel and earn big money. Learn this fascinating profession by home study. Particulars free. Write American School of Criminology, Dept. B, Detroit, Mich.

Armature Winders make big money. We will train you for this interesting profession in 3 to 6 months, and will find you a good paying job while you are learning, so that you can earn your way. Write for special proposition. State age and education. School of Engineering, Dept. R-32, 373 Broadway, Milwaukee, Wis

American Made Toys

An opportunity for Home Workers on small scale and manufacturers on large scale to make American Metal Toys. Army, navy, machine guns, cannons, warships, Indians, cowboys, wild animals, whistles, bird-whistles, religious designs and other toys and novelties. Greatest chance for industrious people to have an independent business. Enormous demand for cheap toys offers unlimited field and great future all over United States and foreign countries. Experience or tools not necessary. Hundreds and more made complete per hour. Casting forms, complete outfit from \$3 up. We buy these goods, paying fixed prices. Attractive prices offered for painted goods. A strictly business proposition. No one need apply unless he means business. Booklet and information furnished free. We have no sales agents and we warn against worthless and cheap imitations. Toy Soldier Manufacturing Co., 32 Union Square, New York.

Salesmen Wanted

Salesmen. Earn \$3,500 to \$10,000 a year. City or Traveling. Experience unnecessary. Quickly qualify through our amazing System. Free Employment Service to Members. Send for Salesmanship book, list of lines and full particulars. National Salesmen's Training Ass'n., Dept. 158W, Chicago, Ill.

Salesman. Side or Main line, to sell low priced 6,000-mile guaranteed automobile tires; 30 x 3 1/2 non-skid sells for \$13.95; other sizes in proportion. Good money-making proposition for live wires. Master Tire Co., 1414 So. Michigan, Chicago.

Business Opportunities

Men, get into the wonderful tailoring agency business, big profits taking orders and your own clothes free. We furnish fine sample outfit and everything free. No experience needed. Write today. Banner Tailoring Co., Dept. 761, Chicago.

Invest One Dollar in complete formula and instruction. Wonderful Developer cuts exposure one half. No more underexposed plates, pictures without flashlight. Sell process or developer to studios it means dollars. Satisfaction guaranteed. Dr. J. H. Stean Research Laboratories, Box 559, Worcester, Mass.

I made \$30 a Week evenings with a small Mail Order Business Home. Free Booklet tells how. 2c postage. Alex Scott, Cohoes, N. Y.

Be Independent. We teach by mail how to manufacture unexcelled toilet goods. Particulars free. School of Cosmetics, Box C, Omaha, Neb.

Enter a new business. Earn \$3,000 to \$6,000 yearly in professional fees making and fitting a foot specialty, openings everywhere with all the trade you can attend to; easily learned by anyone at home in a few weeks at small expense; no further capital required; no goods to buy; job hunting, soliciting or agency. Address Stephenson Laboratory, 18 Back Bay, Boston, Mass.

For \$5 I'll write a circular letter so strenuous, it will have to bring you business. Cash with order. Rosenblum, Advertising Expert, 1482 Broadway, N. Y. Telephone Bryant 2653.

Sell your goods through the mail. Circularize 2500 interested farmers, rural folk, all mail order buyers. Uptodate mailing list \$5.00 complete. Martineks Company, 405 Lexington Avenue, New York.

Dollars Yearly in Your Back Yard. No gin-seng, mushroom dope. New ideas. Investigate. Particulars free. Metz, 313 East 89, New York.

Turn Your Spare Time Into Money for that apparatus you want. Start a profitable, permanent home business. Steady weekly income. No investment but your brains and spare time. Positively no soliciting, agency proposition. Write today. Address Opportunity, Box 175, Fredonia, N. Y.

"Money-Talks." The Business magazine published for progressive people. Send for sample copy. P. O., Box 236-B, Newark, New Jersey.

3,384 Money-making Plans. Formulas. Trade-secrets. "Encyclopedia Business Opportunities," 3 volumes \$1. Ideal Book Shop, 5501-EV North Robey, Chicago.

I represent a firm established 50 years in high grade investment securities yielding 6% to 8%. Will call and give advice. Greater New York and vicinity only. C. H. Fuerstenberg, 404 West 43rd St., New York.

Substantial manufacturing corporation wants capable men to establish branch and manage salesmen. \$300 to \$2,000 necessary. Will allow expenses to Baltimore as explained. Address, Mr. Clemmer, 603 N. Eutaw St., Baltimore, Md.

Breed Canaries. Profitable pastime. Particulars free. Bird Farm, Lynnhaven, Virginia.

If you want to sell or exchange your farm, unimproved land, city property or patent, write me. John J. Black, 194th St., Chippewa Falls, Wis.

Shawnee, Oklahoma center of a great farming country. Write for free agriculture booklet. Board of Commerce, Shawnee, Oklahoma.

\$35 Profit Nightly. Small capital starts you. No experience needed. Our machines are used and endorsed by Government institutions. Catalog free. Atlas Moving Picture Co., 459 Morton Bldg., Chicago.

We will start you in the cleaning and dyeing business, little capital needed, big profits. Write for booklet. The Ben-Vonde System, Dept 14, Charlotte, N. C.

Inventors. List your inventions, patented or not patented, or your practical ideas, with me for sale. State price and terms, send specifications. Thomas Morris, 1927 Manning St., Phila., Pa.

Patents for Sale

Patent for sale. Most educational toy. One wheel car run on between single horizontal cord or rope. Patented the twentieth July this year. Heyiro Sonoda, 6 1/2 Chestnut St., Yakima, Wash.

Will sell or lease patent for improved shoe lacing hook; as simple and practical as the one in common use; cannot catch in garment; lace cannot work off of hook. Description on request. R. E. McCallen, 2092 Oliver Ave., Memphis, Tenn.

Patent. Pencil Lighting Attachment, for use day or night; lease for royalty. Jerrell Bennett, Grapevine, Texas.

Patent Attorneys

Patents. The expert personal service of this firm is of great importance to you in properly protecting your invention by patent. (Est. 1897.) Write to John B. Thomas & Co., 902 F Street, N. W., Washington, D. C.

Patents procured—trade marks registered. A comprehensive, experienced, prompt service for the protection and development of your ideas. Preliminary advice gladly furnished without charge. Booklet of information and form for disclosing idea free on request. Richard B. Owen, 130 Owen Building, Washington, D. C., or 2278T Woolworth Bldg., New York.

Inventors. In all matters pertaining to patents, invention or the sale thereof, consult National Institute of Inventors, 118 Fulton, New York City, society 3000 members, absolute protection. Annual dues \$10. Booklet free.

M. F. Miller, Ouray Bldg., Washington, D. C., Patent Attorney, Mechanical and Electrical Expert. Best quality of work and results. Moderate charges. Advice Free.

Patents, trade-mark, copyright, inventors, business men, artists, write. Metzger, Washington.

Don't lose your rights to patent protection. Before disclosing your invention to anyone send for blank form "Evidence of Conception" to be signed and witnessed. Form and information concerning patents free. Lancaster & Allwine, 242 Ouray Building, Washington, D. C. Originators of the form "Evidence of Conception."

Patents. Herbert Jenner, patent attorney and mechanical expert, 622 F St., Washington, D. C. I report if patent can be had and its exact cost. Send for circular.

Patents. Prompt, personal, efficient service by an attorney-at-law, skilled in all branches of Patent Practice. Over 12 years' actual experience; full information upon request. B. P. Fishburne, 330 McGill Bldg., Washington, D. C.

Patents. Fees in installments. Frank T. Fuller, formerly Lieutenant, Engineers, Washington, D. C.

Get Your Own Patents. Save attorney's fees. Book giving information free. Carl Larsen Co., Park Row Bldg., New York.

Patents. Send for free booklet. Highest references. Best results. Promptness assured. Send model or drawing for examination and opinion. Watson E. Coleman, patent attorney, 624 F St., Washington, D. C.

Inventors. My clients know every step taken in prosecuting their applications. Booklet sent free on request. Warner Cubberly, 22 National Union Bldg., Washington, D. C.

Millions spent annually for ideas. Hundreds now wanted. Patent yours and profit. Write today for free books—tell how to protect yourself, how to invent, ideas wanted, how we help you sell, etc. 212 Patent Dept., American Industries, Inc., Washington, D. C.

For Inventors

"Sell or Finance Inventions." Send for free sample copy of Money-Talks Magazine. P. O. Box 236-B, Newark, N. J.

Inventors. Ideas drawn and blueprinted by experts. Send sketch. Your ideas safe with us. Ordinary blueprint from sketch \$3.00 from exact drawing, \$2.00; extra prints, 25c. each. Aeroplane blueprints, 50c. Wendling Design, 11800 Ablewite Ave., Cleveland, Ohio.

"Inventors' Guide" free on request; gives valuable advice and information for all inventors. Write Frank Ledermann, Registered Patent Attorney, 17 Park Row, New York.

Inventors, protect yourselves. Record idea before exposing it to anyone, even myself or other attorneys. Klein Cons. Eng., Reg. Patent Attorney, 21 Park Row, New York.

Inventors write me about patents. My fees payable monthly. Booklet free. Frank Fuller, Washington, D. C.

900 Mechanical Movements, also illustrations explaining 50 Perpetual Motions. My book, "Inventor's Universal Educator," fifth edition, tells how to procure and sell patents. Government and other costs. Covers the matter from A to Z. 160 pages elegantly bound. Contains noted decisions of U. S. Supreme and State Courts on patent cases. Mechanical Movements greatly assist inventors, suggest new ideas that may prove of great aid in perfecting inventions. Tells how to select an attorney. Has valuable information regarding Patent Sharks, Selling Agents and Brokers. Price \$2. Postage free everywhere. Fred G. Dieterich, 603 Ouray Bldg., Washington, D. C.

Get your own patent, \$35 complete. Full instruction, \$1. Theodore A. Cutting, Campbell, Cal.

We buy practical meritorious inventions or patents or exploit for inventor on dividend basis. California Research Laboratories, 127 South Broadway, Los Angeles.

Inventions Wanted. Cash or royalty for ideas. Adam Fisher Mfg. Co., 205 St. Louis, Mo.

Stammering

St-Stu-t-t-tering and Stammering cured at home. Instructive booklet free. Walter McDonnell, 105 Potomac Bank Bldg., Washington, D. C.

Books

Rare Books. How to write love letters, 25; how to read people's minds, 25c; how to box, 25c; how to make love, 25; how to dance, 25c; Dream Book Fortune Teller, 25c; Vaudeville jokes, 25c; Stage Money, 25c; Gamblers' tricks exposed, 50c. Big catalog free. United Sales Co., Springfield, Ill.

The Amateur Electrician. Pocket Size, 20c (coin). Joel Tillberg, Proctor, Vermont.

No. 1 "The Riddle of Life and Death" Presenting a solution which is both scientific and religious. No. 2 "Where Are the Dead?" Price 10 cents each, postfree. The Rosicrucian Fellowship, Box 132, Oceanside California.

Free—Upon request I will send you illustrated literature describing the following entitled books; Astrology, Character-Reading, Clairvoyance, Concentration, Entertainment, Healing, Hypnotism, Mechanics, Mesmerism, Mysticism, Occultism, Personal Magnetism, Salesmanship, Success, Seer-ship, Mediumship, Will, Yogi Philosophy, etc. A. W. Martens, J. O. O., Burlington, Iowa.

300 Book bargains on Occultism, Mind-reading, Spiritualism, Clairvoyance, Hypnotism, New-Thought, Self-Culture, Drugless-Healing, Sex Secrets, Popular Fiction. Catalog free. C. E. Winegar, Pub., West Fort Ann, N. Y.

Honeymoon—"Instructions for the Honeymoon"; New book, written by physician. Clean, free from vulgarity, yet so plain all may understand. 25c. United Sales Co., Springfield, Ill.

4 books, Seer A. C. Emmerich, Nativity, Egypt, Cana, 20c. Klein Co., Brandon, Minn.

What Every Girl Should Know—By Mrs. Margaret Sanger, the great birth-control advocate. Postpaid, 50 cents. United Sales Co., Springfield, Ill.

Safe and Vault Opening Secrets, Copyrighted; how to open 22 different makes; how to work out systems to open any Safe or Vault; Combination Setting, etc. Start a business of your own. Former price \$25.00—while they last \$5.00, postpaid. Jack Hartmann, Lock Expert, 913 21st Street, Rock Island, Ill.

The Vest Pocket Lawyer; in plain language. Will answer any question. 112 Legal Forms. Cloth binding, 335 pages, \$1.50. Money back if not satisfied. Hazzard Company, Box 1, Vanderveer Park, Brooklyn, N. Y.

Gambling Exposed. Sensational book, exposing secret systems, tricks, scheme and devices gamblers use for cheating with loaded dice, marked cards, etc. Particulars free. United Sales Co., Springfield, Ill.

Perpetual Motion, by Percy Verance. A history of the efforts to discover same from earliest days to the present, together with a scientific discussion regarding the possibility of its ultimate achievement. Profusely illustrated, 367 pages. Price postpaid, \$2.00. The Enlightenment Specialty Co., 305 Fourth St. Edwardsville, Ill.

Rare, Instructive and Entertaining Books. Catalog for stamp. United Sales Co., Springfield, Ill.

Subscription Agents. Best Magazine proposition. Make big money. Write for particulars. Concordia Magazine, 9A Water Street, York, Penna.

Book of Nature. By Dr. Faulkner. Plain facts for those married or about to marry, 25 cents. United Sales Co., Springfield, Ill.

Back Issues of this and other magazines supplied by Boston Magazine Exchange, 107 Mountfort St., Boston.

"White Slavery Exposed." Sensational book, 50c. "Ten Tragedies of Ten Girls." United Sales Co., Springfield, Ill.

Books for Men. Also "classy" pictures. Catalog free. United Sales Co., Springfield, Ill.

125 Card Tricks and how to do them, 25 cents. United Sales Co., Springfield, Ill.

Books on Sex. For men and women. Catalog free. United Sales Co., Springfield, Ill.

For the Hair

I Was Bald. Obtained hair growth by an Indian's ointment containing genuine bear oil and rare plant juices. Many others have had wonderful results. Fine for dandruff. Harmless. Will send box, postpaid, with recipe, 10c. John Hart Brittain, 150 E. 32d St., BB-300, New York.

Formulas

Formulas worth while, profitable operative, effective. Martineks Company, 405 Lexington Avenue, New York.

1,000 Formulas, 25c. Luminous paint—Resilvering mirrors—Renewing Dry batteries—Mechanics' soap—Carbon remover—Gas tonic—Puncture plugger 20c each. Entire collection, 50c. Satisfaction guaranteed. Ideal Book Shop, 5501-EF North Robey, Chicago.

You may have been experimenting for years to make common solder stick to aluminum, but there is a harmless product that will do it. Formula \$1.00. D. Smith, 593 5th St., Oakland, Calif.

New formulas, trade secrets, processes, \$1.00 each. Money back if you want it. Consulting Chemists, Box 270B, Providence, Rhode Island.

1,000,000 Formulas. Processes. Trade secrets for every business. 1016 pages, \$2. Ideal Book Shop, 5501-EE North Robey, Chicago.

For Men

Books and Pictures. Catalog for stamp. United Sales Co., Springfield, Ill.

Send Us Your Dull Safety Razor Blades. We will sharpen them so they shave like new blades for 3c each, any kind. Quick service. Entire satisfaction guaranteed. Antiseptic, Astringent, Pencil given free with every order if you mention "Science and Invention." Send your blades to-day. Keenedge Company, Inc., Dept. L, 184 Washington St., Chicago, Ill.

Detectives earn big money. Travel. Great demand. Fascinating work. Experience unnecessary. We train you. Particulars free. Write, American Detective System, 1968 Broadway, N. Y.

For the Photographer

Do you take pictures? Write for free sample of our big magazine, showing how to make better pictures and earn money. American Photography, 465 Pope Building, Boston, Mass.

Photo Silk. How to print pictures on. Booklet, only \$2.50; Prepared Photosilk per package, only \$2.00. F. Irsa, Elizabeth, N. J.

Exchange

Movie-Outfit. Electric thirty films, screen, twenty-five dollars. Jack Stanton, Care of Billboard Publishing Company, Putnam Bldg., New York.

Let's Swap; Buy, Sell. What'd'ye got? What'd'ye want? Dime quarterly. Swap Bulletin, New York-Detroit.

Sell. Complete chemical laboratory. No trash \$65. Sixty-five Dollars. Mercks tested chemicals. Description free. Arthur Moore, 703 Boissevain Ave., Norfolk, Va.

Wireless instruments Brande's phones, etc. Write for list. Wm. Keen, 1608 Cooper St., Cincinnati, Ohio.

Movie cameras \$43.00. Be our cameraman in your vicinity. Experience unnecessary. Big pay. Professional cameras to our men \$43.00. Lacinema Film Weekly, 157 East 47th Street, New York.

Bargain. \$250.00 Electric and wireless laboratory. Best offer takes. Send stamp and get a big list electrical apparatus and information. Jacob Kamborian, 25 Elton Ave., E. Watertown, Mass.

For Sale. Set Cyclopedia of Applied Electricity. American Technical Society. Walter A. Kopke, 4843 Warner Ave., Chicago, Illinois.

Wanted: Cyclopedia of Applied Electricity. Alfred Haraway, Danville, Va., Route 2.

Will sell or trade wireless, trains, stamps. Want chemicals. Franklin Griffin, 189 Ocean Ave., Jersey City, N. J.

Chemical Laboratory \$35. Wireless \$7.00. Erector \$7.00. Bricktor \$2.50. Train \$15.00. L. Gates, 508 Kelley Ave., Wilksburg, Pa.

Indicating Wattmeter, Range 0-20 Kilowatts, 150 volts, 200 Amps, 125 Cycles. Sell \$30 or trade for 22 Colts Automatic. New condition. H. Flick, 110 East Prospect Blvd., Jackson, Michigan.

Phonograph—Nationola Phonograph. Send stamp for particulars. J. K. Colson, 615 Broad St., New Castle, Ind.

Clock. Mantel Clock 11 by 17 inches. Send stamp for particulars. J. K. Colson, 615 Broad St., New Castle, Ind.

Tone-arms for sale. Including one Pathe. H. W. Secor Laboratory, Island Road, Ramsey, N. J.

Sell. A. C. Weston Ammeter 0-50 A. \$12.00. Chas. McLaughlin, Cadiz, Ohio.

For Sale. All kinds of wireless instruments. Send stamp for reply. Lester Fawcett, 11 North Jackson St., Janesville, Wis.

Wanted. Wireless Receiving Set. Must meet following requirements. Eliminate static; automatically record the received messages. Must employ one mineral detector and one vacuum detector and amplifier. All apparatus to be under cover, easily accessible thru hinged front. Tuning to be done by knobs only. Batteries separate. Price no object. Dr. E. Gray, Paraiso, Tabasco, Mexico.

Telegraphy

Telegraphy (both Morse and Wireless) and Railway Accounting taught quickly. Tremendous demand. Big salaries. Great opportunities. Oldest and largest school; established 46 years. All expenses low—can earn large part. Catalog free. Dodge's Institute, O Street, Valparaiso, Indiana.

Tricks, Puzzles and Games

Free. Big trick and novelty catalog. Send stamp. United Sales Co., Springfield, Ill.

Send ten cents for large (beautifully illustrated) catalogue which contains all the latest tricks, jokes, puzzles and illusions. Oaks Mágical Co., Dept. 549 Oshkosh, Wis.

250 Magic Tricks, explained and illustrated, 10 cents. United Sales Co., Springfield, Ill.

Correspondence Courses

Dollars saved. All kinds of used correspondence courses sold. (Courses bought.) Lee Mountain, Pisgah, Ala.

Educational

Universal Shorthand Course (Pitman) makes stenographic experts in 36 lessons. Efficiency guaranteed or money back. Helps users of other systems increase pay. Easy terms. Write for Booklet 12. Universal Shorthand Course, 6609 Kimbark Avenue, Chicago, Ill.

Learn piano-playing by ear in four lessons. Complete course \$1.00. Results guaranteed. Sterling System Studios, Mount Joy, Pennsylvania.

8 self improved courses \$3.00 each. Send for list. C. G. Cadmus, 3028 St. Clair, E. St. Louis, Ill.

Typewriting, Shorthand, Bookkeeping, Normal, High School, and Law Courses thoroughly taught by mail. Typewriters rented—sold at \$4.00 per month. Carnegie College, Rogers, Ohio.

Before taking any electrical or engineering course, write for details of our special "Earn-Your-Way" proposition. Our wonderful plan of placing students in part-time positions makes it easy for you to become an Electrical Expert or Electrical Engineer. Courses in Electrical Engineering, Practical Electricity, Armature Winding, Starting and Ignition, Radio and Drafting. Learn one of these interesting professions in our big laboratories. Thorough intensive training under a staff of 90 electrical experts. Pleasant surroundings—Fraternity House where you can live at cost, sports, athletics, boating. Write for big free postpaid illustrated book. State age and education, and we will tell you the course for which you are best fitted. School of Engineering, Dept. R-31, 373 Broadway, Milwaukee, Wis.

For Advertisers

Responsible house offers carefully prepared mailing list complete \$5.00: 2500 farmers, rural folk, all mail order buyers. Martineks Company, 405 Lexington Avenue, N. Y.

Advertise. Eighteen words in 100 syndicate magazines, \$1; extra words, 6 cents each. Lists free Stanford Corporation, Lancaster, Pa.

Putting punch in small space is best accomplished with Jacobus Art ads. Price \$5.00. Send details and \$1. Sketch will be sent on approval Jacobus Advertising Service, 41 Bruen Ave., Irvington, N. J.

Electrical Supplies and Appliances

Blueprints. Electrical connections. Alternating and direct current motors, voltage changing, etc. Also transformers, rheostats, controllers, compensators, automobile generator, armature connections. 10 samples A.C., 25c. Particulars free. Charles Chittenden, A3024 Matthews, Kansas City Missouri.

Amateurs. List of interesting chemical experiments 25c. How to build simple electric motor 25c. Box 5, Hingham Center, Mass.

Mansfield's Automatic Water and Oil Finder a proved success, silver medal awarded. Particulars from Edwin A. Mansfield & Co., 94 Victoria Road, New Brighton, England.

Experimenters, inventors, model-builders; requiring mechanical parts in small quantities made to order from sketches and specifications. Springs of all descriptions, gears, pinions, racks, sprocket-wheels, sprocket-chains, worms, Universal-joints, ball-bearings, Straight face and Grooved pulleys; shafting, etc. Small delicate castings in iron, brass or aluminum, either rough on machined, also sheet metal stampings. August Johnson, 835 Newton Ave., Erie, Pa.

Our New Circuit Tester, a combination of high-grade Buzzer, Lamp, Telephone, Receiver and Flashlight-Battery, is indispensable for electricians, telephone and wireless work, owners of autos and motor-boats, garages, repair stations, etc. Weight without telephone only 17 ounces. Small, neat, rugged construction. Moderate price. Electric Signal Manufacturing Company, Inc., 31 Tremont Ave. Orange, N. J., manufacturers of high-grade Bells and Buzzers.

Build Dry Cells. Blueprints and instructions 25c. Carroll, Jones Court, Newton, Mass.

To order. Metal articles, models, tools, patterns, experimenting, manufacturing. Inventions developed Cleveland Specialty & Manufacturing Co., Cleveland, So. Brooklyn, Ohio.

Welding Instructions for operating Oxy-Acetylene apparatus on all metals; sent postpaid fifty cents. Address E. E. Bertschy, Cedar Rapids, Iowa.

Electrical Workers and All Others who are interested in electrical work in the reconstruction that is taking place. To send us their name and receive descriptive literature of our modern blueprint chart method of electrical wiring. Souvenir information card included. Electrical Wiring Diagram Co., Box C-173, Altoona, Pa.

Build an Electric Motor. Complete outfit \$2.00. Blueprint 25c. A. F. Cassel, 52 West 130th St., New York City.

Gravity Batteries complete \$1 each. Send for free circular. H. Henderson, Lake Arthur, New Mex.

Health

Cigarette, pipe or chewing habit conquered. Guaranteed. Write for free brochure. Edw. J. Woods, TB-300, Station F, New York.

Tobacco or Snuff Habit Cured or no pay; \$1 if cured. Remedy sent on trial. Superba Co., SA, Baltimore, Md.

Pyorrhoea. (Rigg's Disease—Bleeding or Swollen Gums.) Hundreds have been helped by our successful home treatment. Purifying, healing, preventative. Full month's treatment consisting of a very beneficial massage paste and an antiseptic tooth-cleaning paste to be used in place of your ordinary dentifrice together with full directions for treatment. \$1 postpaid. Or, write for free Booklet "E". Pyorem Mfg. Co., 439 Seventh Street, Brooklyn, New York.

Too Fat? Reduce Weight easily, pleasantly. No self-starvation, no strenuous exercise; reliable, guaranteed. Obtain Oil of Korein at any busy pharmacy or write for free brochure to Korein Co., NA-300, Sta. F, New York.

Free. Stop using tobacco. We will give free information how to conquer habit easily and permanently. Results guaranteed. Anti-Tobacco League, Dept. C, Omaha, Nebr.

Instruction

Crystal Gazing. The Craze. Send self-addressed stamped envelop for Free instructions. Zancigs Studio, Asbury Park, N. J.

Newspaper Work. Proofreading for magazines and publishers well-paid, pleasant work; excellent opportunity. Positions open in all large cities. Easily learned by mail. Cost is low. Diploma issued. Write today for full information. Publishers School of Proofreading, 662 Foster Building, 280 Madison Avenue, New York.

Mathematics taught by mail. Spare time home study course including arithmetic, geometry, algebra and trigonometry. J. A. Harding, 485 Glendale Ave., Detroit, Mich.

Ask Us. Authoritative answers on any popular electrical or technical subject, 25 cents. Consulting Service, 493 32nd St., Millwaukee, Wis.

Detectives earn big money. Excellent opportunity. Learn fascinating profession by correspondence. Great demand everywhere. Particulars free. Write, American Detective System, 1968 Broadway, N. Y.

Motion Picture Plays

Author's Instructive hand-books and faultless literary service. Writers Service, Princeton, Ind.

Photoplays Wanted. Big prices paid. You can write them. We show you how. Free particulars. Rex Publishers, Box 175, E-20, Chicago.

Earn \$1,200 a year in spare time writing photoplays. Experience unnecessary. Send for free book, valuable information, special prize offer. Photo Playwright College, Box 278 E-10, Chicago.

Miscellaneous

Wanted. Small gasoline and steam engines, electric drills, motors, etc. Will pay high cash prices for good material. Johnston, West End, Pittsburgh, Pa.

Sportsmen. Trained beagles, rabbit, fox, coon, skunk, squirrel and opposum dogs, bird dogs, pet and farm dogs, swine, rabbits, pigeons, pheasants, goats, 100 varieties of blooded stock. Circulars 10c. Violet Hill Kennels, York, Pa.

Electrical Tattooing Machine \$3, \$5 and \$7. Catalogue for stamps. J. H. Temke, 1019 Vine, Exp. Cincinnati, Ohio.

Personal Magnetism wins every time. No different what you want; try it. "The Way to Win" helps you, 10c. "How to Read Thoughts" and Mind Reading at any Distance 30c. "How to Hypnotize", Relieve Disease, Give astounding Exhibitions \$1.00. "How to Make Free Shows", highly profitable, \$1.00. "Hypnotic Wonders" free. Science Institute, ES 6435 No. Clark, Chicago.

Reproduce pictures from newspapers also colored cartoons on any sheet of paper with Wonder-Wax. Clear-Simple. Something new. Send 10c to Medoff & Rafner, 30 Boerum St., Brooklyn, N. Y.

Trained fox and wolf hounds. Also Coon and Varmint hounds on trial. John W. Burks, Bolivar, Mo.

See around corners and over brick walls with a trench periscope. Working blueprints and simple instructions for making your own sent on receipt of 25c. coin, or 22c. money order (Stamps not accepted). Lewis Designing Laboratory, Box 263, Cleburne, Texas.

Boys—become expert at wing and trap shooting with shotgun or rifle—use air rifle for practice. Full instructions for one dollar. No money Orders. Address W. B. Brown, White, Pa.

Kentuckys, extra fine chewing and smoking tobacco for sale, aged in bulk, hand prepared and in twist, ready for use, nice, rich, and mellow. Satisfaction guaranteed. Order quick before it is all gone; 8 pounds \$6.80 postpaid. Reference, 1st National Bank here, Bardwell, Ky.

Musical Instruments

Violins, deep, mellow, soulful, on credit. Easy terms for wonderful instrument. Get details today. Gustav A. Henning, 2424 Gaylord St., Denver, Colo.

\$2.00 Harmonicas imported from Germany \$1.00. Others 75c. 50c., 40c. Post Office Drawer 1319, San Francisco.

Novelties

Motion Picture Show, with stage appearance, screen, and continuous pictures 50c. Rempe, 2827 Myrtle St., Oakland, Calif.

Mysterious Wonder Shavings, new Japanese novelties; when dropped into water turn into babies, flowers, fish. Dozen in pretty package, 15c; three, 35c. Excellent dinner party favors; they create talk. Twelve packages, \$1.00. George P Heinemann, 1424 Rosemont, Chicago.

Genuine Indian Baskets, Wholesale Catalog. Marion Gilhams, Highland Springs, California.

Submarine Chemical Gardens. Beautiful and mystifying. Entertaining and interesting to young and old. Packed complete postpaid 50c. Chemical Novelty Co., 236 Gordon Ave., Syracuse, N. Y.

Office Devices

Addressographs, Multigraphs, Duplicators, Folders, Sealers. Bought, Sold. Guaranteed Office Device Company, 156-X North La Salle, Chicago.

Multigraphs, Addressographs, Duplicators, Sealers, Folders. Less than half price. Guaranteed one year. Pruitt Company, 112-C North La Salle, Chicago.

Old Coins Wanted

We Buy and Sell Old Coins. \$2 to \$500 each paid. Keep All Old Money; you may have valuable coins. Send 10c. for New Illustrated Coin Value Book, 4 x 6. Guaranteed, prices. Get posted. Clarke Coin Co., Box 110, Le Roy, N. Y.

Printing

3000 two color labels, \$1.25. Irvin J. Wolf, Station E, Philadelphia.

2000 Gummed labels 1 x 2, \$1.25. Lowest prices other sizes and styles. Simplex Label House, 3253 North Herndon Street, Chicago.

100 name cards, leatherette case 75c. Agents 50% profit. \$5.00 daily. Information. Wolf, Desk J. Station E, Philadelphia.

Phonographs

Make Your Own Phonograph. Particulars free. DeSeIO-PhonE, P. O. Box 720, Attica, Indiana.

Build your own phonographs and manufacture them for profit. Drawing, Instructions, Parts Price List, Blue Print, etc., complete, sent free upon request. Write today. Associated Phonograph Co., Dept. E 1, Cincinnati.

Build a genuine Choraleon Phonograph and save over half. Fine profits building and selling. We furnish motors, tone arms and necessary parts. Send for our catalog and free blue-print offer. Choraleon Phonograph Co., 1220 14th St., Elkhart, Ind.

Build Your Phonograph. "Perfection" high-quality spring and electric motors, tone arms, reproducers. Wonderful results. Big saving. New catalog and building instructions mailed for 10 cents. Indiana Phonograph Supply Co., Indianapolis, Ind.

Postcards and Pictures

Art lovers and artists, if interested in real art pictures, real thing kind, we can supply your wants; our pictures please everyone; sample 30c. set of six \$1.50. Send 50c (silver) for our Fall Art Catalog, containing 200 illustrations; it will surprise you. Gordon's Specialty House, P. O. Box 1231, Los Angeles, California.

"Way of Man and Maid" Picture you'll like, 3 x 5, sealed, 20c. Select Club, Dept. S., Topeka, Kansas.

Special. Twenty clever, classy, assorted postcards, 10c prepaid. Swanson, 1205 E. Kansas Ave., Kansas City, Kansas.

Everything in postcards. Live-wire list free. Worth-while samples, 25c. Mention subjects preferred. Mutual Supply Co., Bradford, Pa.

Chemicals

Book of 100 experiments only 25c. Oliver R. Stalter, Oshawa, Ontario, Canada.

Chemicals, chemical apparatus, books, sets. Everything for the laboratory. Price list 5 cents. National Scientific Supply Co., 241 Pa. Ave., Washington, D. C.

"The Experimenters Supply House" has some interesting literature to send to amateur chemists. It's free. D. Altman Co., 223-225 East 110th Street, New York. "Practical" Laboratories.

Test Tubes 6 in. 25c dozen. Qualitative analysis chart 2 feet long 85c. Catalog of Chemical Apparatus for stamp. Enola Scientific Co., 3326-17th Washington, D. C.

Personal

Tobacco, liquor or morphine habits easily banished. Hill's Chloride of Gold Tablets will overcome any of these habits quickly and permanently. Perfectly harmless, cause no sickness, can be given secretly in tea or coffee. Particulars sent sealed free. The Ohio Chemical Works, Dept. 7, Charleston, S. C.

Unsightly Facial Moles. Removed forever with "Nevitol" which simply dries them up without pain or injury to your skin in the privacy of your home. Particulars free. Williams Chemical Laboratory, Dept. E, Charleston, S. C.

Rubber Stamps

Rubber Stamps made to order. McCaddon Company, Zanesville, Ohio.

Song Poems

Write the Words for a Song. We will write the music and guarantee publication on a royalty basis. Submit poems on any subject. Seton Music Company, 920 S. Michigan Ave., Room 111, Chicago, Ill.

You Write Words for a Song. We write the music, publish, and secure a copyright. Submit poems on any subject. The Metropolitan Studios, 914 S. Michigan Ave., Dept. 209, Chicago, Illinois.

You write the Words for a Song. We'll compose the music free and publish same. Send Song Poem today. S. Lenox Co., 271 West 125th St., New York City.

Song-writers' Manual and Guide Sent Free! Contains valuable instructions and advice. Submit song-poems for examination. We will furnish music, copyright and facilitate publication or sale. Knickerbocker Studios, 319 Gaiety Bldg., New York.

Hibbeler's valuable information to song poem writers. 10c. Ray Hibbeler, D115, 4040 Dickens Ave., Chicago.

Write a Song Poem. I compose music and guarantee publication. Send poem today. E. Hanson, 3810 Broadway, Room 108, Chicago.

Write the Words for a Song. We revise poems, write music and guarantee to secure publication. Submit poems on any subject. Broadway Studios, 197C Fitzgerald Bldg., New York.

Stamps and Coins

Free stamps, album, lists 5c. Buckley, 712-B Bowen, Dayton, Ohio.

250 Different Postage Stamps 25c. Border Cities Stamp Shop, Box 702, Walkerville, Ont., Canada.

50 Sarre, Esthonia, Poland Cesko, Latvia, Travancore, etc., 25c. Nutley Stamp Exchange, Nutley, N. J.

Stamps—20 all different free. Postage, 3c. Mention paper. Quaker Stamp Co., Toledo, Ohio.

California Gold, quarter size, 27c; half-dollar size, 53c. Columbian nickel and catalogue 10c. Norman Shultz, King City, Mo.

California Gold, quarter and Colombia nickel coin 30c. Italy 20 Con and catalog 10c. Homer Shultz, King City, Mo.

Photo Developing

Mail Us 20c with any size film for development—and six velvet prints. Or send six negatives any size and 20c for six prints. Or send 40c for one 8 x 10 mounted enlargement. Prompt, perfect service. Roanoke Photo Finishing Co., 255 Bell Ave., Roanoke, Virginia.

Enlargements. Mail us one dollar bill and favorite negative for two 8 x 10 or four 5 x 7 mounted enlargements of finest quality. Write for price list. Prompt service. Quality Studio, Box 81, Berwick, Ohio.

Send 15 cents and two negatives; will make 6 prints on post cards. Negatives returned. Phil Lunsted, Cape Cottage, Maine.

Wireless

Dead? Your "A" battery, we mean. Always ready if you use our B-B battery booster; charges your battery over night for 10 cents. Soon pays for itself. Every amateur needs one. \$15. It's ready to ship you. Hi Co., Marion, Ill.

Good Radio Receiving Sets \$8.50 and up. Panel transmitting sets, \$30.95 and up. Radiophone apparatus, wire, supplies of all kinds. Catalog 3-E for 2-cent stamp. Pocket code card free. Jenkins, 923 Purchase St., New Bedford, Mass.

Radio phonists attention. High voltage generators. We supply these motor generator sets in various capacities, especially designed for radio phone work, also low powered rotary converters, dynamotors, fractional H.P. motors and storage batteries. We are in a position to solve your generator problems and supply machines to fill your requirements. We also have the standard RAY-DI-CO phone sets complete, or furnish any part thereof. In fact, if it is radio equipment of any kind, or a set of your own design, write us, stating your wants and become acquainted with our service. RAY-DI-CO (Not Inc.), 2653 B, N. Clark St., Chicago, Ill.

Used apparatus bargains. Remarkable values. List free. Central Radio, Independence, Missouri.

One-half K.W. transmitter for sale, \$60. Send stamp for description. O. R. Wimpy, 116 Sheetz St., LaFayette, Ind.

Ventriloquism

Ventriloquism taught almost anyone at home. Small cost. Send today 2-cent stamp for particulars and proof. Geo. W. Smith, Room R699, 125 North Jeff Ave., Peoria, Ill.

Scenery for Hire

Collapsible Scenery and Plush Drops. Amelia Grain, Philadelphia.

Machinery, Tools and Supplies

Automatic Air Compressor, also Motor Buffer. Terms if desired. Hobartsons, Troy, Ohio.

Wanted to Buy

You can raise cash by mailing us any old, broken jewelry, diamonds, platinum, broken watches, false teeth, bracelets, old-gold, silver, silver plate, magneto points, platinum wire, contact points or crucibles, mercury, and all valuables. We pay the highest prices in spot cash by return mail, and will return your goods in ten days if you're not satisfied. The Ohio Smelting & Refining Company, 206 Lennox Bldg., Cleveland, Ohio.

Welding

Electric Motors, two and five horsepower. Hobertsons, Troy, Ohio.

Advertisement for 'The Electrical Experimenter' bound volume No. VII. The image shows a thick book with the title 'THE ELECTRICAL EXPERIMENTER VOL. 7 1919-20' on the spine. Text below the image reads: 'Bound Volume No. VII of ELECTRICAL EXPERIMENTER Price \$2.00 This volume comprises the issues of May, 1919, to April, 1920, inclusive. Over 1,300 pages, 2,400 illustrations, and countless articles, diagrams and formulas. It is a complete cyclopedia of scientific development written in non-technical language. It contains interesting and valuable ideas for many months to come. Attractively bound, stamped in gold. A welcome addition to your library. Send for your copy today. Experimenter Publishing Co. 236 Fulton St. New York City'



Complete Set of Drawing Instruments

Yes, I will give you this complete drawing outfit absolutely free. The instruments are in a handsome high class, plush lined folding case. They are regular draftsman's working instruments. Besides I will give you absolutely free, a 20x25 inch drawing board, a 24 inch T square, a 12 inch rule, a supply of drawing paper, two triangles, a French curve, pencils, erasers, thumb tacks, etc. The complete outfit is delivered to you at once. You have them to work with from the very first day. Find out about this offer. Write today.

Be a Draftsman Draw \$3,600 Per Year

There is an urgent demand for skilled draftsmen. Companies are issuing calls every day for men to fill positions paying \$3,600 per year. Work is light, pleasant and profitable.

Pay As You Wish What I want is the *right kind* of men. Don't bother about expense. I will give you the working outfit free if you get in at once. I charge a very small fee for training you to be an experienced draftsman. You can pay the small cost as suits you best.

Chief Draftsman Will Instruct You Personally

I am Chief Draftsman of a large and well known firm. I know just the kind of training that is demanded from men who get big salaries. I want to train a limited number to take big paying drafting positions. I train you by giving you actual, practical work, the kind that you must be able to do to hold permanent, high salaried jobs. I give you my individual instructions. If your work is right, I will advance you rapidly. If it is wrong, I will show you where and make you do it right, and do all I can to make you an expert draftsman and designer in a short time.

Send Coupon for My Big New Book

Put your name and address on the coupon and send it to me today. I will send you my new book "Successful Draftsmanship," and the great special offer that I am now making on which you get the complete Draftsman's Working Outfit absolutely free. You assume no obligations of any kind in sending coupon. Get in line for a big paying position. Getting the book and full particulars of the special offer is the first step.

Chief Draftsman Dobe, Dept. 5339, 4001 Broadway, Chicago, Ill.

Chief Draftsman Dobe

Dept. 5339, 4001 Broadway, Chicago, Ill.

Without any obligations on me whatsoever, please mail your book "Successful Draftsmanship," and full particulars of your liberal "Personal Instruction" offer to a few students. It is understood that I am obligated in no way whatever.

Name.....

Address.....

Post Office.....State.....



Every Electrical Man Wants These Books and we ship them for your inspection **FREE**

Flexible
Covers
—
Handy
Pocket
Size
Volumes

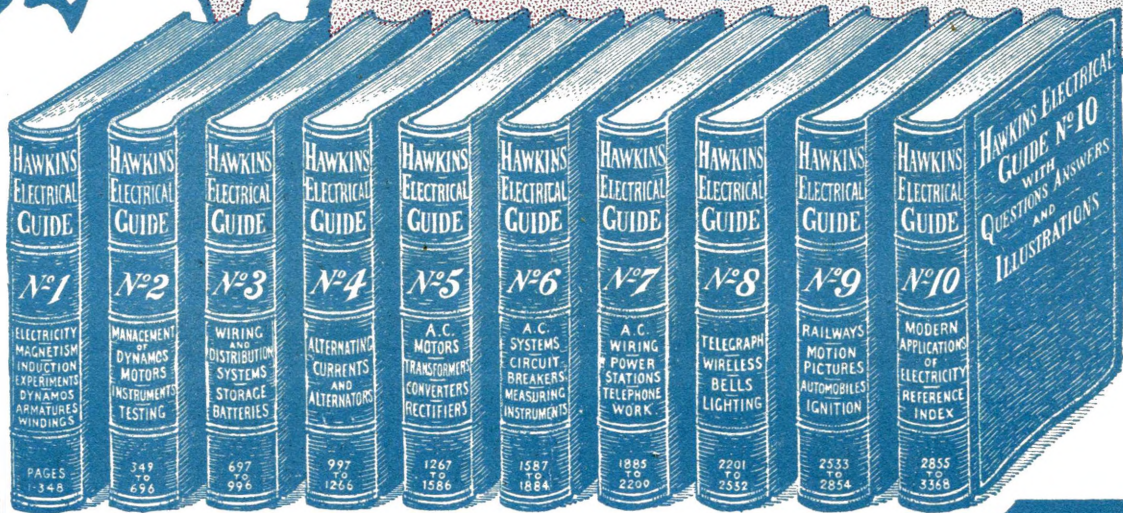

10
Volumes
3500
Pages
4700
Pictures
\$1 Per
Volume
\$1 Per
Month

Just what you need to know to succeed in **ELECTRICITY**

EVERY electrician, every engineer, every mechanic should know about these wonderfully helpful instructive books, which give in plain words a complete working knowledge of electrical engineering in all its phases.

You run into some new electrical problem almost every day. The information you need to help you in your every day work is in

HAWKINS ELECTRICAL GUIDES

These books place electricity at your finger ends. They cover every imaginable subject, principle, theory, problem, trouble, and way of doing things electrically. Every subject is indexed so that you can turn right to it. They are a study course and a reference guide in one, written in plain every day language—no wasted words—only what you need to know—chock full of up-to-the-minute electrical knowledge. The guides are a complete course in electrical engineering. They will help you in every detail of the day's electrical work. You can't ask an electrical question that Hawkins Guides can't answer.

Pocket - Size Flexible Covers

The books are small enough to slip into your coat pocket—handsomely bound in flexible black covers.

You can carry each volume with you until you have mastered its contents. 3,500 pages of actual information and 4,700 illustrations. Once you see these books and put them into actual use you will never again want to be without them. Try it at our expense.

SEND NO MONEY

It will cost you nothing to receive these books—to look them over—ask them all the questions you can think of—use them in your work—study them—pick up some information that will increase your earning ability. We will ship you the entire set of 10 volumes entirely FREE.

This is a sign of our confidence in the guides. Pure gold does not object to being tested. Keep them for seven days and if you do not decide that you can't get along without them, return them to us and owe us nothing.

When you decide to keep them you only have to pay \$1.00 down and remit the balance of \$9 on the easy payment of \$1.00 a month till paid for.

Use this coupon to get the books. It will pay you many times over.

THEO. AUDEL & CO.
72 Fifth Ave. New York, N. Y.

SEND NO MONEY-USE THE COUPON

READ THIS PARTIAL LIST OF CONTENTS

- No. 1** Contains 348 pages, 388 illustrations. Electrical signs and symbols—static and current electricity—primary cells—conductors and insulators—resistance and conductivity—magnetism—induction coils—dynamo principles—classes of dynamos—armatures—windings—commutation—brushes, etc.
- No. 2** Contains 348 pages, 394 illustrations. Motor principles—armature reaction—motor starting—calculations—brake horsepower—selection and installation of dynamo and motors—galvanometers—standard cells—current measurement—resistance measurement—voltmeters—wattmeters—watt hour meters—operation of dynamos—operation of motors, etc.
- No. 3** Contains 300 pages, 423 illustrations. Distribution systems—wires and wire calculations—inside, outside and underground wiring—sign flashers—lightning protection—rectifiers—storage battery systems, etc.
- No. 4** Contains 270 pages, 379 illustrations. Alternating current principles—alternating current diagrams—the power factor—alternator principles—alternator construction—windings, etc.
- No. 5** Contains 320 pages, 614 illustrations. A. C. Motors—synchronous and induction motor principles—A. C. commutator motors—induction motors, transformers; losses, construction, connections, tests—converters, rectifiers, etc.
- No. 6** Contains 298 pages, 472 illustrations. Alternating current systems—switching devices—circuit breakers—relays—lightning protector apparatus—regulating devices—synchronous condensers—indicating devices—meters—power factor indicators—wave form measurement—switchboards, etc.
- No. 7** Contains 316 pages, 379 illustrations. Alternating current, wiring power stations—turbines; management, selection, location, erection, testing, running, care and repair—telephones, etc.
- No. 8** Contains 332 pages, 436 illustrations. Telegraph—simultaneous telegraphy and telephony wireless—electric lighting—photometry, etc.
- No. 9** Contains 322 pages, 627 illustrations. Electric railways—electric locomotives—car lighting—trolley car operation—miscellaneous applications—motion pictures—gas engine ignition—automobile self-starters and lighting systems, electric vehicles, etc.
- No. 10** Contains 513 pages, 599 illustrations. Elevators—cranes—pumps—air compressors—electric heating—electric welding—soldering and brazing—industrial electrolysis—electro plating—electro-therapeutic—X-rays, etc.

Also a complete 126-page ready reference index of the complete library. This index has been planned to render easily accessible all the vast information contained in the 10 electrical guides. There are over 13,500 cross references. You find what you want to know instantly.

THEO. AUDEL & CO.
72 Fifth Ave.
New York, N. Y.

Please submit me for examination Hawkins Electrical Guides (price \$1 each). Ship at once, prepaid, the 10 numbers. If satisfactory I agree to send you \$1 within seven days and to further mail you \$1 each month until paid.

Signature.....
Occupation.....
Employed by.....
Residence.....
Reference..... S. & I. Dec.

What Electrical Men Say

Helped Him Make Good

"It is only right for me to recommend highly the Hawkins Guides, for they have been of the greatest assistance to me in placing me in my present position as Superintendent of Construction Department of one of Ohio's largest Electrical Companies. I would like to see every man have a set of Hawkins Guides."
Geo. Knecht, Columbus, Ohio.

In the Naval Electrical Dept.

"The Hawkins Guides are great help to me in the Naval Electrical Department, which they cover very thoroughly."
C. J. Cornell,
U. S. Receiving Ship, Brooklyn, N. Y.

Superintendent

"I am now superintendent of the Dunnville Hydro-Electric Systems, and Hawkins Guides were a great help to me in holding down a responsible position."
W. E. Swartz, Dunnville, Ontario.

Wireless Operators

"I have worked wireless for ten years—but I wish I had these books years ago, as they have saved me a good deal of trouble."
E. Marshall,
Steamer M & B No. 2,
Walkerville, Ont.



The Burlington

Twenty One Jewels

"Fewer Jewels Not Worthy of the Name Burlington"

Adjusted to the Second—Adjusted to Temperature—Adjusted to Isochronism—Adjusted to Positions
25-Year Gold Srata Case—Genuine Montgomery Railroad Dial—New Art designs—Extra Thin Cases

Burlington Watch Co.
 Dept. 5339, 19th St. & Marshall Blvd., Chicago
 338 Portage Avenue, Winnipeg, Manitoba

Please send me (without obligation and prepaid) your free book on watches with full explanation of your cash or \$5.00 a month offer on the Burlington Watch.

Name.....
 Address.....

\$5⁰⁰ a Month

You pay only this small amount each month for this masterpiece, sold to you at the direct rock-bottom price, the lowest price at which a Burlington is sold. This masterpiece of watch manufacture is adjusted to position, adjusted to temperature, and adjusted to isochronism. Send coupon today for free book on watches.

Send the Coupon You do not pay a cent until you see the watch. Send the coupon today for this great book on watches and full information of the \$5.00 a month offer on the Burlington Watch. Don't delay. **Ac TODAY—RIGHT NOW!**